

มาตรฐานผลิตภัณฑ์อุตสาหกรรม

THAI INDUSTRIAL STANDARD

มอก. 1334 เล่ม 1 – 2550

ISO 834 – 1 : 1999

การทดสอบความทนไฟ - ชิ้นส่วนต่าง ๆ ของโครงสร้างอาคาร

เล่ม 1 ข้อกำหนดทั่วไป

FIRE - RESISTANCE TESTS - ELEMENTS OF BUILDING CONSTRUCTION

PART 1 : GENERAL REQUIREMENTS

สำนักงานมาตรฐานผลิตภัณฑ์อุตสาหกรรม

กระทรวงอุตสาหกรรม

ICS 19.020.00; 13.220.50

ISBN 978-974-292-489-8

มาตรฐานผลิตภัณฑ์อุตสาหกรรม
การทดสอบความทนไฟ - ชิ้นส่วนต่าง ๆ
ของโครงสร้างอาคาร
เล่ม 1 ข้อกำหนดทั่วไป

มอก. 1334 เล่ม 1— 2550

สำนักงานมาตรฐานผลิตภัณฑ์อุตสาหกรรม
กระทรวงอุตสาหกรรม ถนนพระรามที่ 6 กรุงเทพฯ 10400
โทรศัพท์ 02 202 3300

ประกาศในราชกิจจานุเบกษาฉบับประกาศและงานทั่วไปเล่ม 124 ตอนพิเศษ 201ง
วันที่ 21 ธันวาคม พุทธศักราช 2550

มาตรฐานผลิตภัณฑ์อุตสาหกรรม การทดสอบความทนไฟ- ชั้นส่วนต่างๆของโครงสร้างอาคาร เล่ม 1 ข้อกำหนดทั่วไปนี้ ได้ประกาศใช้ครั้งแรกเป็นมาตรฐานผลิตภัณฑ์อุตสาหกรรม การทดสอบความทนไฟ- ชั้นส่วนต่างๆของโครงสร้างอาคาร มาตรฐานเลขที่ มอก.1334-2539 (ISO 834-1975 Amendment 2-1980) ประกาศในราชกิจจานุเบกษา ฉบับประกาศทั่วไป เล่ม 113 ตอนที่ 48 ง วันที่ 13 มิถุนายน พุทธศักราช 2539 ต่อมาเอกสารอ้างอิง ISO 834 ได้แก้ไขใหม่โดยแยกออกเป็น 8 เล่ม คือ

- (1) ISO 834-1:1999 Fire -resistance tests - Elements of building construction Part 1 : General requirements
- (2) ISO/TR 834-3:1994 Fire -resistance tests - Elements of building construction Part 3 : Commentary on test method and test data application
- (3) ISO 834-4:2000 Fire -resistance tests - Elements of building construction Part 4: Specific requirements for loadbearing vertical separating elements
- (4) ISO 834-5:2000 Fire -resistance tests - Elements of building construction Part 5: Specific requirements for loadbearing horizontal separating elements
- (5) ISO 834-6:2000 Fire -resistance tests - Elements of building construction Part 6: Specific requirements for beams
- (6) ISO 834-7:2000 Fire -resistance tests - Elements of building construction Part 7: Specific requirements for columns
- (7) ISO 834-8:2002 Fire -resistance tests - Elements of building construction Part 8: Specific requirements for non-loadbearing vertical separating elements
- (8) ISO 834-9:2003 Fire -resistance tests - Elements of building construction Part 9 Specific requirements for non-loadbearing ceiling elements

ดังนั้น เพื่อให้สอดคล้องกับเอกสารอ้างอิง จึงได้แก้ไขปรับปรุงมาตรฐานดังกล่าว โดยแยกเป็น 8 มาตรฐาน สำหรับมาตรฐานผลิตภัณฑ์อุตสาหกรรม การทดสอบความทนไฟ- ชั้นส่วนต่างๆของโครงสร้างอาคาร เล่ม 1 ข้อกำหนดทั่วไปนี้เป็นเล่มหนึ่งในมาตรฐานผลิตภัณฑ์อุตสาหกรรมดังกล่าว

มาตรฐานผลิตภัณฑ์อุตสาหกรรมนี้กำหนดขึ้นโดยรับ ISO 834-1 : 1999 Fire - Resistance tests - Elements of building construction Part 1: General requirements มาใช้ในระดับเหมือนกันทุกประการ (identical) โดยใช้ ISO ฉบับภาษาอังกฤษเป็นหลัก

มาตรฐานผลิตภัณฑ์อุตสาหกรรมนี้กำหนดขึ้นเพื่อให้ทันกับความต้องการของผู้ใช้และจักได้แปลเป็นภาษาไทยในโอกาสอันสมควร หากมีข้อสงสัยโปรดติดต่อสอบถามที่สำนักงานมาตรฐานผลิตภัณฑ์อุตสาหกรรม

คณะกรรมการมาตรฐานผลิตภัณฑ์อุตสาหกรรมได้พิจารณามาตรฐานนี้แล้ว เห็นสมควรเสนอรัฐมนตรีประกาศตาม มาตรา 15 แห่งพระราชบัญญัติมาตรฐานผลิตภัณฑ์อุตสาหกรรม พ.ศ. 2511



ประกาศกระทรวงอุตสาหกรรม

ฉบับที่ 3789 (พ.ศ. 2550)

ออกตามความในพระราชบัญญัติมาตรฐานผลิตภัณฑ์อุตสาหกรรม

พ.ศ. 2511

เรื่อง ยกเลิกมาตรฐานผลิตภัณฑ์อุตสาหกรรม

การทดสอบความทนไฟ-ชิ้นส่วนต่าง ๆ ของโครงสร้างอาคาร

และกำหนดมาตรฐานผลิตภัณฑ์อุตสาหกรรม

การทดสอบความทนไฟ-ชิ้นส่วนต่าง ๆ ของโครงสร้างอาคาร เล่ม 1 ข้อกำหนดทั่วไป

โดยที่เป็นการสมควรปรับปรุงมาตรฐานผลิตภัณฑ์อุตสาหกรรม การทดสอบความทนไฟ-ชิ้นส่วนต่าง ๆ ของโครงสร้างอาคาร มาตรฐานเลขที่ มอก.1334-2539

อาศัยอำนาจตามความในมาตรา 15 แห่งพระราชบัญญัติมาตรฐานผลิตภัณฑ์อุตสาหกรรม พ.ศ. 2511 รัฐมนตรีว่าการกระทรวงอุตสาหกรรมออกประกาศยกเลิกประกาศกระทรวงอุตสาหกรรม ฉบับที่ 2136 (พ.ศ.2539) ออกตามความในพระราชบัญญัติมาตรฐานผลิตภัณฑ์อุตสาหกรรม พ.ศ.2511 เรื่อง กำหนดมาตรฐานผลิตภัณฑ์อุตสาหกรรม การทดสอบความทนไฟ-ชิ้นส่วนต่าง ๆ ของโครงสร้างอาคาร ลงวันที่ 5 เมษายน พ.ศ.2539 และออกประกาศกำหนดมาตรฐานผลิตภัณฑ์อุตสาหกรรม การทดสอบความทนไฟ-ชิ้นส่วนต่าง ๆ ของโครงสร้างอาคาร เล่ม 1 ข้อกำหนดทั่วไป มาตรฐานเลขที่ มอก.1334 เล่ม 1-2550 ขึ้นใหม่ ดังมีรายการละเอียดต่อท้ายประกาศนี้ ทั้งนี้ให้มีผลตั้งแต่วันที่ประกาศในราชกิจจานุเบกษา เป็นต้นไป

ประกาศ ณ วันที่ 12 กันยายน พ.ศ. 2550

โสมิต ปั้นเปี่ยมรัษฎ์

รัฐมนตรีว่าการกระทรวงอุตสาหกรรม

มาตรฐานผลิตภัณฑ์อุตสาหกรรม

การทดสอบความทนไฟ-

ชิ้นส่วนต่างๆของโครงสร้างอาคาร

เล่ม 1 ข้อกำหนดทั่วไป

บทนำ

มาตรฐานผลิตภัณฑ์อุตสาหกรรมนี้กำหนดขึ้นโดยรับ ISO 834-1 : 1999 Fire - Resistance tests - Elements of building construction - Part 1: General requirements มาใช้ในระดับเหมือนกันทุกประการ (identical) โดยใช้ ISO ฉบับภาษาอังกฤษเป็นหลัก

ขอบข่าย

มาตรฐานผลิตภัณฑ์อุตสาหกรรมนี้กำหนดวิธีทดสอบหาค่าความทนไฟของชิ้นส่วนต่างๆ ของโครงสร้างอาคารเมื่อเผชิญไฟมาตรฐาน ผลทดสอบที่ได้สามารถนำไปใช้ในการจัดจำแนกสมรรถนะความทนไฟของชิ้นทดสอบได้บนพื้นฐานของระยะเวลาที่ชิ้นทดสอบผ่านเกณฑ์ที่กำหนด

เอกสารอ้างอิง

รายละเอียดให้เป็นไปตาม ISO 834-1 : 1999 ข้อ 2

บทนิยาม

บทนิยามที่ใช้ในมาตรฐานผลิตภัณฑ์อุตสาหกรรมนี้ให้เป็นไปตาม ISO 834-1 : 1999 ข้อ 3

สัญลักษณ์

รายละเอียดให้เป็นไปตาม ISO 834-1 : 1999 ข้อ 4

เครื่องมือทดสอบ

รายละเอียดให้เป็นไปตาม ISO 834-1 : 1999 ข้อ 5

ภาวะทดสอบ

รายละเอียดให้เป็นไปตาม ISO 834-1 : 1999 ข้อ 6

การเตรียมชิ้นทดสอบ

รายละเอียดให้เป็นไปตาม ISO 834-1 : 1999 ข้อ 7

การใช้เครื่องมือ

รายละเอียดให้เป็นไปตาม ISO 834-1 : 1999 ข้อ 8

กระบวนการทดสอบ

รายละเอียดให้เป็นไปตาม ISO 834-1 : 1999 ข้อ 9

เกณฑ์สมรรถนะ

รายละเอียดให้เป็นไปตาม ISO 834-1 : 1999 ข้อ 10

ความใช้ได้ของการทดสอบ

รายละเอียดให้เป็นไปตาม ISO 834-1 : 1999 ข้อ 11

การแสดงผลทดสอบ

รายละเอียดให้เป็นไปตาม ISO 834-1 : 1999 ข้อ 12

รายงานผลทดสอบ

รายละเอียดให้เป็นไปตาม ISO 834-1 : 1999 ข้อ 13

Fire-resistance tests – Elements of building construction –

Part 1: General requirements

1 Scope

This part of ISO 834 specifies a test method for determining the fire resistance of various elements of construction when subjected to standard fire exposure conditions. The test data thus obtained will permit subsequent classification on the basis of the duration for which the performance of the tested elements under these conditions satisfies specified criteria.

2 Normative references

The following standards contain provisions which, through reference in this text, constitute provisions of this part of ISO 834. At the time of publication, the editions indicated were valid. All standards are subject to revision, and parties to agreements based on this part of ISO 834 are encouraged to investigate the possibility of applying the most recent editions of the standards indicated below. Members of IEC and ISO maintain registers of currently valid International Standards.

ISO 13943:—¹⁾, *Fire safety — Vocabulary*.

IEC 60584-1:1995, *Thermocouples — Part 1: Reference tables*.

3 Definitions

For the purposes of this part of ISO 834, the definitions given in ISO 13943 and the following definitions apply.

3.1 actual material properties: Properties of a material determined from representative samples taken from the specimen for the fire test according to the requirements of the concerned product standard.

3.2 calibration test: Procedure to assess the test conditions experimentally.

3.3 deformation: Any change in dimension or shape of an element of construction due to structural and/or thermal actions. This includes deflection, expansion or contraction of elements.

1) To be published.

3.4 element of building construction: Defined construction component, such as a wall, partition, floor, roof, beam or column.

3.5 insulation: Ability of a separating element of building construction when exposed to fire on one side, to restrict the temperature rise of the unexposed face to below specified levels.

3.6 integrity: Ability of a separating element of building construction, when exposed to fire on one side, to prevent the passage through it of flames and hot gases or the occurrence of flames on the unexposed side.

3.7 loadbearing capacity: Ability of a specimen of a loadbearing element to support its test load, where appropriate, without exceeding specified criteria with respect to both the extent of, and rate of, deformation.

3.8 loadbearing element: An element that is intended for use in supporting an external load in a building and maintaining this support in the event of a fire.

3.9 neutral pressure plane: Elevation at which the pressure is equal inside and outside the furnace.

3.10 notional floor level: Assumed floor level relative to the position of the building element in service.

3.11 restraint: The constraint to expansion or rotation (induced by thermal and/or mechanical actions) afforded by the conditions at the ends, edges or supports of a test specimen.

NOTE — Examples of different types of restraint are longitudinal, rotational and lateral.

3.12 separating element: An element that is intended for use in maintaining separation between two adjacent areas of a building in the event of a fire.

3.13 supporting construction: That construction that may be required for the testing of some building elements into which the test specimen is assembled, such as the wall into which a door is fitted.

3.14 test construction: Complete assembly of the test specimen together with its supporting construction.

3.15 test specimen: Element (or part) of a building construction provided for the purpose of determining either its fire resistance or its contribution to the fire resistance of another building element.

4 Symbols

| Symbol | Description | Unit |
|-----------------|---|-----------------------------------|
| A | area under the actual average furnace time/temperature curve | $^{\circ}\text{C}\cdot\text{min}$ |
| A_s | area under the standard time/temperature curve | $^{\circ}\text{C}\cdot\text{min}$ |
| C | axial contraction measured from the start of heating | mm |
| $C(t)$ | axial contraction at time t during the test | mm |
| $\frac{dC}{dt}$ | rate of axial contraction, defined as: $\frac{C(t_2) - C(t_1)}{(t_2 - t_1)}$ | mm/min |

| | | |
|----------------------|--|--------|
| <i>d</i> | distance from the extreme fibre of the design compression zone to the extreme fibre of the design tensile zone of the structural section of a flexural test specimen | mm |
| <i>D</i> | deflection measured from the commencement of heating | mm |
| <i>D(t)</i> | deflection at time <i>t</i> during the test | mm |
| $\frac{dD}{dt}$ | rate of deflection, defined as: $\frac{D(t_2) - D(t_1)}{(t_2 - t_1)}$ | mm/min |
| <i>h</i> | initial height of axially loaded specimen | mm |
| <i>L</i> | length of the clear span of the specimen | mm |
| <i>d_e</i> | percent deviation (see 6.1.2) | % |
| <i>t</i> | time from the commencement of heating | min |
| <i>T</i> | temperature within the test furnace | °C |

5 Test equipment

5.1 General

Equipment employed in the conduct of the test consists essentially of the following:

- a specially designed furnace to subject the test specimen to the test conditions specified in the appropriate clause;
- control equipment to enable the temperature of the furnace to be regulated as specified in 6.1;
- equipment to control and monitor the pressure of the hot gases within furnace as specified in 6.2;
- a frame in which the test specimen can be erected and which can be positioned in conjunction with the furnace so that appropriate heating, pressure and support conditions can be developed;
- arrangement for loading and restraint of the test specimen as appropriate, including control and monitoring of loads;
- equipment for measuring temperature in the furnace and on the unheated face of the test specimen, and where needed within the test specimen construction;
- equipment for measuring the deformation of the test specimen where specified in the appropriate clauses;
- equipment for evaluating test specimen integrity and for establishing compliance with the performance criteria described in clause 10 and for establishing the elapsed time.

5.2 Furnace

The test furnaces shall be designed to employ liquid or gaseous fuels and shall be capable of

- a) heating of vertical or horizontal separating elements on one face; or
- b) heating of columns on all sides; or
- c) heating of walls on more than one side; or
- d) heating of beams on three or four sides, as appropriate.

NOTE — Furnaces may be designed so that assemblies of more than one element can be tested simultaneously, provided all the requirements for each individual element can be complied with.

The furnace linings shall consist of materials with densities less than 1 000 kg/m³. Such lining materials shall have a minimum thickness of 50 mm and shall constitute at least 70 % of the internally exposed surface of the furnace.

5.3 Loading equipment

The loading equipment shall be capable of subjecting test specimens to the level of loading determined according to 6.4. The load may be applied hydraulically, mechanically or by the use of weights.

The loading equipment shall be able to simulate conditions of uniform loading, point loading, concentric loading or eccentric loading, as appropriate for the test construction. The loading equipment shall also be capable of maintaining the test load at a constant value (to within ± 5 % of the required value) without changing its distribution for the duration of the loadbearing capacity period. The equipment shall be capable of following the maximum deformation and the rate of deformation of the test specimen for the duration of the test.

The loading equipment shall not significantly influence the heat transfer through the specimen nor impede the use of the thermocouple insulating pads. It shall not interfere with the measurement of surface temperature and/or deformation and shall permit general observation of the unexposed face. The total area of the contact points between the loading equipment and the test specimen surface shall not exceed 10 % of the total area of the surface of a horizontal test specimen.

Where loading has to be maintained after the end of heating, provision shall be made for such maintenance.

5.4 Restraint and support frames

Special frames or other means shall be used to reproduce the boundary and support conditions appropriate for the test specimens as specified in 6.5.

5.5 Instrumentation

5.5.1 Temperature

5.5.1.1 Furnace thermocouples

The furnace thermocouples shall be plate thermometers which comprise an assembly of a folded steel plate, the thermocouple fixed to it and containing insulation material. The measuring and recording equipment shall be capable of operating within the limits specified in 5.6.

The plate part shall be constructed from (150 ± 1) mm long by (100 ± 1) mm wide by $(0,7 \pm 0,1)$ mm thick nickel alloy sheet strips folded to the design as shown in figure 1.

The measuring junction shall consist of nickel chromium/nickel aluminium (type K) wire as defined in IEC 60584-1, contained within mineral insulation in a heat-resisting steel alloy sheath of nominal diameter 1 mm, the hot junctions being electrically insulated from the sheath. The thermocouple hot junction shall be fixed to the geometric centre of the plate in the position shown in figure 1 by a small steel strip made from the same material as the plate. The steel strip can be welded to the plate or may be screwed to it to facilitate replacement of the thermocouple. The strip shall be approximately 18 mm by 6 mm if it is spot welded to the plate, and nominally 25 mm by 6 mm if it is to be screwed to the plate. The screw shall be 2 mm in diameter.

The assembly of plate and thermocouple shall be fitted with a pad of inorganic insulation material nominally (97 ± 1) mm by (97 ± 1) mm by (10 ± 1) mm thick, density (280 ± 30) kg/m³.

Before the plate thermometers are first used, the complete plate thermometer shall be aged by immersing in a pre-heated oven at 1 000 °C for 1 h.

NOTE — Exposure in a fire resistance furnace for 90 min under the standard temperature/time curve is considered to be an acceptable alternative to using an oven.

When a plate thermometer is used more than once, a log of its use shall be maintained indicating, for each use, the checks made and duration of use. The thermocouple and the insulation pad shall be replaced after 50 h exposure in the furnace.

5.5.1.2 Unexposed surface thermocouples

The temperature of the unexposed surface of the test specimen shall be measured by means of disc thermocouples of the type shown in figure 2. In order to provide a good thermal contact, thermocouple wires, 0,5 mm in diameter, shall be soldered or welded to a 0,2 mm thick by 12 mm diameter copper disc. Each thermocouple shall be covered with a 30 mm x 30 mm x 2,0 mm \pm 0,5 mm thick inorganic insulating pad, unless specified otherwise in the standards for specific elements. The pad material shall have a density of $900 \text{ kg/m}^3 \pm 100 \text{ kg/m}^3$. The measuring and recording equipment shall be capable of operating within the limits specified in 5.6.

The insulating pad shall be bonded to the surface of the test specimen, with no adhesive between the copper disc and the specimen surface or between the copper disc and the insulating pad.

5.5.1.3 Roving thermocouples

One or more roving thermocouples of the design shown in figure 3 or alternative temperature-measuring devices which can be shown to have at least the accuracy and a response time equal to or less than the design illustrated by figure 3 shall be available to measure the unexposed surface temperature during a test in positions where higher temperatures are suspected. The measuring junction of the thermocouple consists of 1,0 mm diameter thermocouple wires soldered or welded to a 12 mm diameter, 0,5 mm thick copper disc. The thermocouple assembly shall be provided with a handle so that it can be applied over any point on the unexposed surface of the test specimen.

Dimensions in millimetres

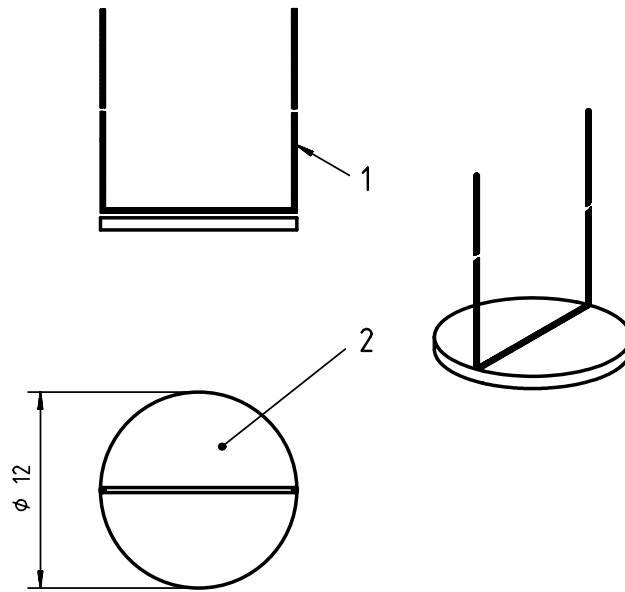

Key

- 1 Thermocouple wire, of 0,5 mm diameter
- 2 Copper disc, 0,2 mm thick

a) Copper disc measuring junction

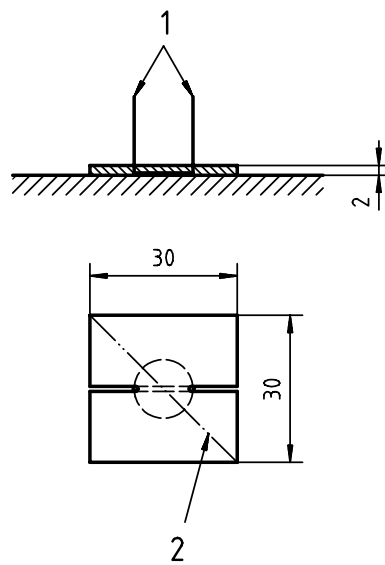

Key

- 1) Cuts to allow pad to be positioned over copper disc
- 2) Alternative cut location

b) Copper disc and insulating pad

Figure 2 — Unexposed surface thermocouple and insulating pad

Dimensions in millimetres

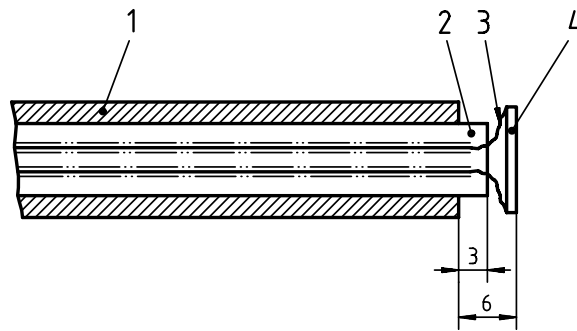

Key

- 1) Heat-resistant steel support tube, of 13 mm diameter
- 2) Twin-bore ceramic insulator, of 8 mm diameter
- 3) Thermocouple wire, of 1,0 mm diameter
- 4) Copper disc, 12 mm in diameter, 0,5 mm thick

Figure 3 — Roving thermocouple assembly

5.5.1.4 Internal thermocouples

When information concerning the internal temperature of a test specimen or particular component is required, it shall be obtained by means of thermocouples having characteristics appropriate to the range of temperatures to be measured as well as being suitable for the type of materials in the test specimen.

5.5.1.5 Ambient-temperature thermocouples

A thermocouple shall be used to indicate the ambient temperature within the laboratory in the vicinity of the test specimen both prior to and during the test period. The thermocouple shall be nominally of 3 mm diameter, mineral insulated, stainless-steel sheathed type K, as defined in IEC 60584-1. The measuring junction shall be protected from radiated heat and draughts.

5.5.2 Pressure

The pressure in the furnace shall be measured by means of one of the designs of sensors shown in figure 4. The measuring and recording equipment shall be capable of operating within the limits specified in 5.6.

Dimensions in millimetres

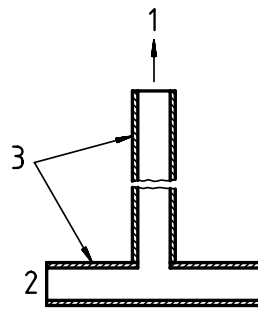

Key

- 1) To pressure transducer
- 2) Open
- 3) Stainless-steel tube (inside diameter 5 mm to 10 mm)

a) Type 1 - "T" shaped sensor

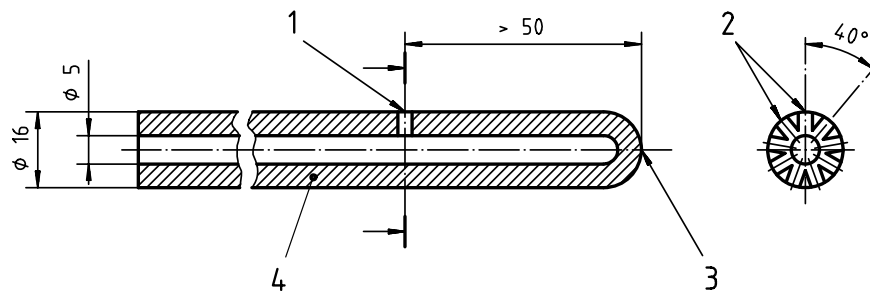

Key

- 1) Holes, of 3,0 mm diameter
- 2) Holes, of 3,0 mm diameter, spaced 40° apart around the pipe
- 3) Welded end
- 4) Stainless-steel pipe

b) Type 2 - Tube sensor

Figure 4 — Pressure-sensing heads

5.5.3 Load

When using weights, no further measurement of load in a test is needed. The loads applied by hydraulic loading systems shall be measured by means of a load cell or other relevant equipment having the same accuracy or by monitoring the hydraulic pressure at an appropriate point. The measuring and recording equipment shall be capable of operating within the limits specified in 5.6.

5.5.4 Deformation

Deformation measurements can be made by using equipment employing mechanical, optical or electrical techniques. Where such equipment is used in relation to performance criteria (e.g. measurements of

deflection or contraction), it shall be capable of operating at a frequency of at least one reading per minute. All necessary precautions shall be taken to prevent any drift in the sensor readings due to heating.

5.5.5 Integrity

5.5.5.1 Cotton pad

Unless specified otherwise in the standards for specific elements, the cotton pad used in the measurement of integrity shall consist of new, undyed and soft cotton fibres without other added fibres, 20 mm thick \times 100 mm square, and shall weigh between 3 g and 4 g. It shall be conditioned prior to use by drying in an oven at $100^{\circ}\text{C} \pm 5^{\circ}\text{C}$ for at least 30 min. After drying it may be stored in a desiccator or other moisture-proof container until use. For use, it shall be mounted in a wire frame, as shown in figure 5, provided with a handle.

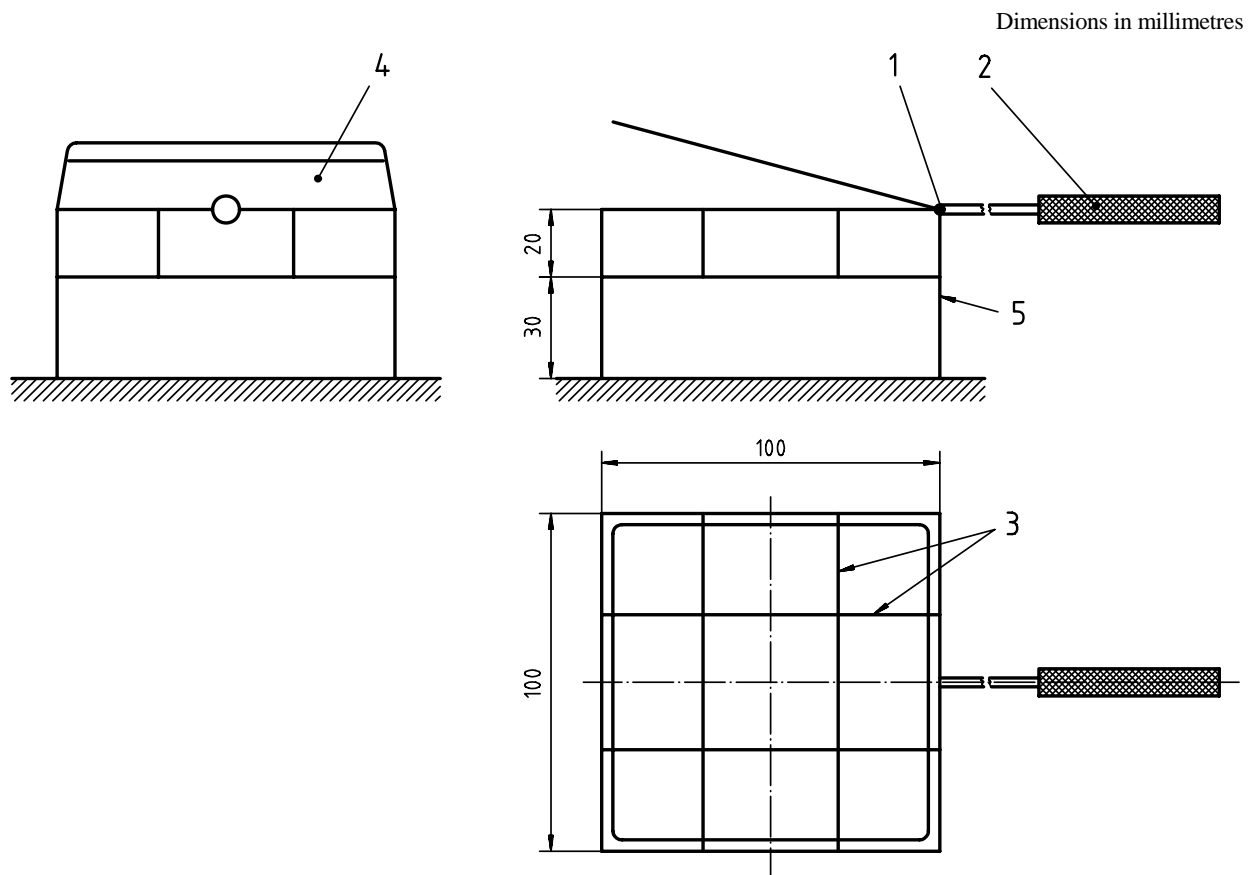

Key

- 1) Hinge
- 2) Handle of suitable length
- 3) Supporting steel wire of 0,5 mm diameter
- 4) Hinged lid with latch
- 5) Framework of steel wire of 1,5 mm diameter

Figure 5 — Cotton pad holder

5.5.5.2 Gap gauge

Two types of gap gauge, as shown in figure 6, shall be available for the measurement of integrity. They shall be made of cylindrical stainless steel rod of 6 mm \pm 0,1 mm and 25 mm \pm 0,2 mm diameter. They shall be provided with insulated handles of suitable length.

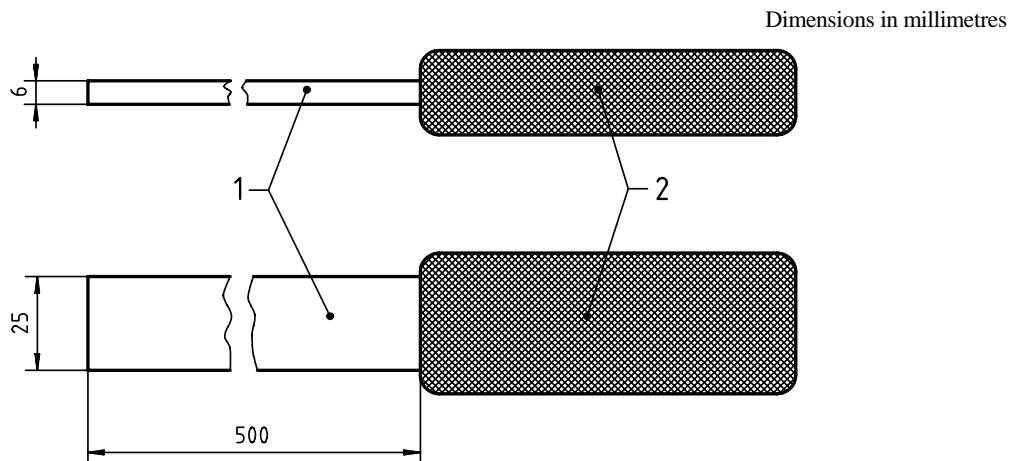

Key

- 1) Stainless steel rod
- 2) Insulated handle

Figure 6 — Gap gauges

5.6 Accuracy of measuring equipment

For conducting fire tests, the measuring equipment shall meet the following levels of accuracy:

- | | | |
|--|----------------------------|----------------------------|
| a) temperature measurement: | furnace | $\pm 15^{\circ}\text{C}$; |
| | ambient and unexposed face | $\pm 4^{\circ}\text{C}$; |
| | other | $\pm 10^{\circ}\text{C}$; |
| b) pressure measurement: | | $\pm 2 \text{ Pa}$; |
| c) load level: | | $\pm 2,5 \%$ of test load; |
| d) axial contraction or expansion measurement: | | $\pm 0,5 \text{ mm}$; |
| e) other deformation measurements: | | $\pm 2 \text{ mm}$; |

6 Test conditions

6.1 Furnace temperature

6.1.1 Heating curve

The average temperature of the furnace, as derived from the thermocouples specified in 5.5.1.1, shall be monitored and controlled such that it follows the relationship (see figure 7):

$$T = 345 \log_{10}(8t + 1) + 20$$

where

- T is the average furnace temperature, in degrees Celsius;
- t is the time, in minutes.

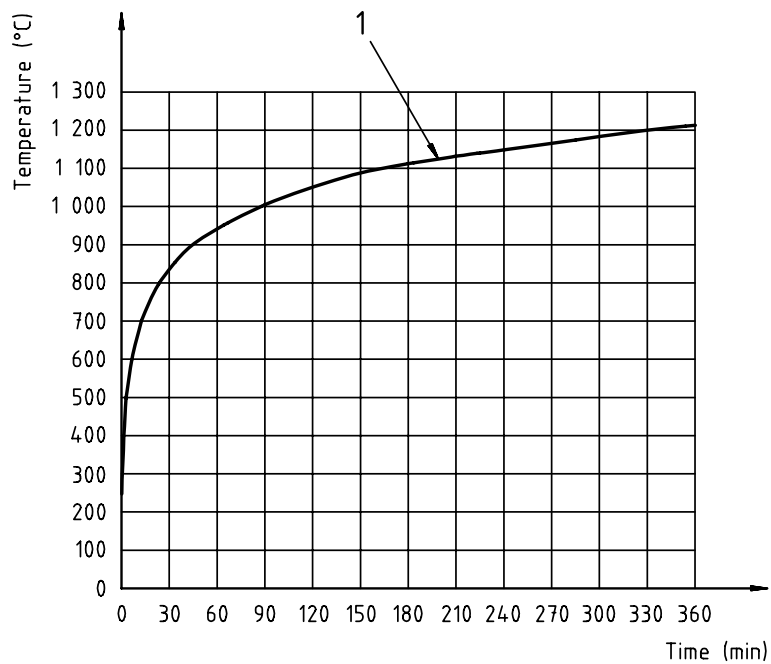

Key

- 1 Furnace temperature versus time

Figure 7 — Standard time/temperature curve

6.1.2 Tolerances

The percent deviation d_e in the area of the curve of the average temperature recorded by the specified furnace thermocouples versus time from the area of the standard time/temperature curve shall be within

- a) $d_e \leq 15 \%$ for $5 < t \leq 10$;
- b) $d_e = 15 - 0,5 (t - 10) \%$ for $10 < t \leq 30$;
- c) $d_e = 5 - 0,083 (t - 30) \%$ for $30 < t \leq 60$;
- d) $d_e = 2,5 \%$ for $t > 60$;

$$d_e = \frac{A - A_s}{A_s} \times 100$$

where

d_e is the percent deviation;

A is the area under the actual average furnace time/temperature curve;

A_s is the area under the standard time/temperature curve;

t is the time, in minutes.

All areas shall be computed by the same method, i.e. by the summation of areas at intervals not exceeding 1 min for a) and 5 min for b), c) and d) and shall be calculated from time zero. The start of the test is described in 9.3.

At any time after the first 10 min of test, the temperature recorded by any thermocouple in the furnace shall not differ from the corresponding temperature of the standard time/temperature curve by more than 100 °C.

For test specimens incorporating a significant amount of combustible material, the deviation may be exceeded for a period not in excess of 10 min provided that such excess deviation is clearly identified as being associated with the sudden ignition of significant quantities of combustible materials increasing the average furnace temperature.

6.2 Furnace pressure differential

6.2.1 General

A linear pressure gradient exists over the height of furnace, and although the gradient will vary slightly as a function of the furnace temperature, a mean value of 8 Pa per meter height may be assumed in assessing the furnace pressure conditions.

The value of the furnace pressure at a specified height shall be the nominal mean value, disregarding fluctuations of pressure associated with turbulence, etc., and shall be established relative to the pressure outside the furnace at the same height. The mean value of the furnace control pressure shall be monitored in accordance with 9.4.2 and controlled for the first 5 min from the commencement of the test to ± 5 Pa and for 10 min to ± 3 Pa.

6.2.2 Vertical elements

The furnace shall be operated such that a pressure of zero is established at a height of 500 mm above the notional floor level. However the pressure at the top of the test specimen shall not be greater than 20 Pa, and the height of the neutral pressure plane shall be adjusted accordingly.

6.2.3 Horizontal elements

The furnace shall be operated such that a pressure of 20 Pa is established at a position 100 mm below the underside of the test specimen or the notional ceiling level when testing beams.

6.3 Loading

The testing laboratory shall indicate clearly the basis on which the test load has been determined. The test load can be determined on the basis of one of the following:

- a) the actual material properties of the test specimen and a design method specified in a recognized structural code;
- b) the characteristic material properties of the test specimen and a design method specified in a recognized structural code; wherever possible, the relationship between the loadbearing capacities determined on the basis of the characteristic and the actual material properties shall be given;
- c) a service load given in a code of practice on the use of the construction or indicated by the sponsor for a particular use. The relationship between the service loadbearing capacity and the load determined on the basis of the distribution of material properties one can expect for the test specimen and the characteristic material properties assigned to the test specimen shall be given or shall be experimentally determined.

6.4 Restraint/Boundary conditions

The test specimen shall be mounted in a special support and restraint frame in such a way that the methods adopted for supporting the ends or the sides during the test simulate, in a representative and definable manner, those which would be applied to a similar element in service.

The boundary conditions may provide for restraint against expansion, contraction or rotation. Alternatively the boundary conditions may offer freedom for deformation to occur. A test specimen may be tested with one or other of these boundary conditions applied to all or only some of its edges. The choice of the conditions shall be made on the basis of a careful analysis of the conditions that apply in practice.

Test specimens representative of elements with uncertain or variable boundary conditions in service, shall be supported at the edges or at the ends in such a manner as to provide conservative results.

If restraint is applied during the test, then the restraint conditions shall be described with regard to the free movement of the element prior to encountering resistance to expansion, contraction or rotation. As far as possible, the external forces and moments which are transmitted to the element by restraint during the test shall be recorded.

6.5 Ambient conditions

The furnace should be installed in a laboratory of sufficient size to prevent the ambient air temperature in the vicinity of a separating element increasing by more than 10 °C above the initial temperature whilst the test specimen is complying with the insulation criterion. The laboratory atmosphere shall be virtually draught-free. The ambient air temperature shall be 20 °C ± 10 °C at the commencement of the test and it shall be monitored at a distance of 1,0 m ± 0,5 m from the unexposed face under conditions such that the sensor is not affected by thermal radiation from the test specimen and/or furnace (particularly in the case of an element which only needs to satisfy the integrity criteria).

6.6 Deviation from specified test conditions

Should the conditions of furnace temperature, furnace pressure or ambient temperature which are achieved during the test represent a more severe exposure of the test specimen, this shall not automatically make the test invalid (see clause 11 on validity of the test).

6.7 Calibration

When the standard for calibration is completed, the control of the furnace with respect to parameters such as

- thermal exposure conditions
- pressure conditions
- oxygen content

shall follow the requirements of that standard.

7 Test specimen preparation

7.1 Construction

Materials used in the construction of the test specimen and the method of construction and erection shall be representative of the use of the element in practice. It is important to carry out its construction using the standard of workmanship normally provided in buildings including appropriate surface finish, if any. No variation in construction (e.g. different jointing systems) shall be included in a single test specimen. Any modifications made to accommodate the installation of a test specimen within the specified support and restraint frame shall be such as to have no significant influence on the behaviour of the test specimen and shall be fully described in the test report.

7.2 Size

The test specimen shall be normally full size. When the specimen cannot be tested full size, the specimen size shall be in accordance with the test standard for the individual elements.

7.3 Number of test specimens

At least one test specimen for each specified support or restraint condition shall be tested. For separating elements of an asymmetrical construction required to resist fire from either side, test specimens representative of the construction shall be subjected to fire exposure from each side unless it can be established that the fire exposure of a particular face would be more onerous. Separating elements of an

asymmetrical construction required to resist fire from one specified side only shall be subjected to fire exposure from that side only.

7.4 Conditioning

At the time of the test, the strength and moisture content of the test specimen shall approximate the conditions expected in normal service. If the test specimen contains or is liable to absorb moisture, it shall not be tested until it has reached an air-dry condition. This condition shall be considered as that which would be established at equilibrium resulting from storage in an ambient atmosphere of 50 % relative humidity at 23 °C.

One method of achieving an air-dry condition is to store the specimen in an enclosure (minimum temperature 15 °C, maximum relative humidity 75 %) for the time needed to reach moisture equilibrium. This is attained when two successive weighing operations carried out at an interval of 24 h do not differ by more than 0,1 % of the mass of the specimen.

Accelerated conditioning is permissible provided the method does not alter the properties of component materials or the moisture distribution in the specimen so that it has influence on the fire behaviour of the specimen. High temperature conditioning shall be below temperatures critical for the materials.

If, after conditioning, it is not possible to achieve the specified moisture condition, but the design strength of the absorptive component has been attained, the test specimen may then be subjected to the fire test.

Representative samples may be used for moisture content determination and conditioned with the test specimen. These should be so constructed as to represent the loss of water vapour from the test specimen by having similar thicknesses and exposed faces. Test specimens shall be conditioned to an invariable moisture content.

Standards for specific elements may contain additional or alternative rules for obtaining moisture equilibrium.

7.5 Test specimen verification

The sponsor shall provide a description of all constructional details, drawings and schedule of major components and their manufacturer/supplier, and an assembly procedure to the test laboratory, prior to the test. This shall be done sufficiently in advance of the test to assist the laboratory which shall verify the conformity of the test specimen with the information provided, as far as possible, and any area of discrepancy which shall be resolved prior to starting the test. In order to ensure that the description of the element, and its construction in particular, is in conformity with the element tested, the laboratory shall either verify the fabrication of the element or request one or more additional test specimens.

On occasion it may not be possible to verify the conformity of all aspects of the test specimen construction prior to the test and adequate evidence may not be available after test. When it is necessary to rely on information provided by the sponsor, then this shall be clearly stated in the test report. The laboratory shall nevertheless ensure that it fully appreciates the design of the test specimen and shall be confident that it is able to accurately record the constructional details in the test report. Additional procedures for specimen verification will be found in the test methods for specific products.

8 Application of instrumentation

8.1 Temperature

8.1.1 Furnace thermocouples (plate thermometers)

The plate thermometers employed to measure the temperature of the furnace shall be distributed so as to give a reliable indication of the average temperature in the vicinity of the test specimen. The number and position of plate thermometers for each type of element is specified in the specific test method.

Plate thermometers shall be positioned so that they are not in contact with flames from the furnace burners and that they are at least 450 mm away from any wall, floor or roof of the furnace.

At the commencement of the test the plate thermometers shall be (100 ± 50) mm from the exposed face of the test construction and they shall be maintained at this distance during the test, as far as possible.

The method of support shall ensure that plate thermometers do not fall away or become dislodged during the test.

At the commencement of the test, the furnace shall include at least the number of plate thermometers (n) that are required by the specific test method. If plate thermometers fail so that they are $n - 1$ in the furnace, then the laboratory need take no action. If the number falls below $n - 1$ during the test then the laboratory shall replace these to ensure that at least $n - 1$ are present.

Plate thermometers are resistant to damage but are subject to damage by falling debris and deteriorate in continued use, becoming slightly less sensitive with age. Before every test they shall be inspected and checked for proper operation. If there is any evidence of damage, deterioration or improper operation, they shall not be used and shall be replaced.

The support for the plate thermometers shall not penetrate or be attached to the specimen unless the specific requirements for the position of the measuring junction cannot otherwise be ensured. If the support for the measuring junction has penetrated or been attached to the specimen, it shall be arranged so as to have minimal effect on the behaviour of the specimen in relation to the relevant failure criteria or the supplementary information being determined.

8.1.2 Unexposed surface thermocouples

Surface thermocouples of the type described in 5.5.1.2 shall be attached to the unexposed face, to measure the average and the maximum temperature rise.

The average temperature rise on the unexposed surface shall be based upon measurements obtained from surface thermocouples located at or near the centre of the test specimen and at or near the centre of each quarter section. With corrugated or ribbed constructions, the number of thermocouples can be increased to have appropriate representation on the maximum and minimum thickness. The positioning of these thermocouples should avoid, by a minimum of 50 mm, thermal bridges, joints, junctions and through connections, and fixings such as bolts, screws, etc., as well as locations where the thermocouples may be exposed to the direct impingement of gases passing through the test specimen.

Additional thermocouples shall be attached to measure the maximum temperature rise at locations where high temperature conditions are expected to exist. None of the thermocouples shall be located over fasteners such as screws, nails, or staples that can have higher temperatures if the aggregate area of any part of

such fasteners is less than one per cent of the area within any 150 mm diameter circle. Thermocouples shall not be placed on such fasteners with a smaller surface diameter than 12 mm unless they extend through the assembly. For those fasteners smaller than 12 mm, special measuring devices can be used. More specific information on surface thermocouple locations is given in the appropriate test method for a particular element.

Thermocouples should preferably be attached to the surface of the specimen by the use of heat-resisting adhesive, without any adhesive between the copper disc and the specimen or the copper disc and the pad, taking care to ensure that the air gap between them, if any, is a minimum. Where glueing is not possible, pins, screws or clips which are only in contact with those parts of the pad which are not over the disc shall be used.

8.1.3 Roving thermocouple

A roving thermocouple in accordance with 5.5.1.3 shall be applied to any suspected hot spot which develops during the test. There is no reason to retain application until a steady state is obtained if a temperature of 150 °C is not achieved within an application period of 20 s. Measurements with the roving thermocouple shall avoid fasteners such as screws, nails or staples that will be obviously higher or lower in temperature, as already specified for the additional, unexposed surface thermocouple locations.

8.1.4 Interior thermocouples

When used, internal thermocouples in accordance with 5.5.1.4 shall be fixed so as not to affect the performance of the test specimen. The hot junction may be attached in the appropriate position by suitable means including peening into steel sections. As far as possible, the thermocouple wires shall be prevented from becoming hotter than the junction.

NOTE — Wherever possible, the first 50 mm of the wires adjacent to the thermocouple should be in an isothermal plane.

8.2 Pressure

The pressure sensors (see 5.5.2) should be located where they will not be subject to direct impingement of convection currents from the flames or in the path of the exhaust gases. They shall be installed such that the pressure can be measured and monitored to provide the conditions specified in 6.2. The tubes shall be horizontal both in the furnace and as they exit through the furnace wall, such that the pressure is relative to the same positional height from the inside to the outside of the furnace. If “T” shaped sensors are used, “T” branches shall be horizontally oriented. Any vertical section of tube to the measuring instrument shall be maintained at room temperature.

8.2.1 Furnaces for vertical elements

One pressure sensor shall be provided to control furnace pressure, and shall be located within 500 mm of the neutral pressure plane. A second sensor may be used to provide information on the vertical pressure gradient within the furnace. This sensor shall be located within 500 mm of the top of the test specimen.

8.2.2 Furnaces for horizontal elements

Two pressure sensors shall be provided in the same horizontal plane but in different positions relative to the perimeter of the test specimen. One shall be used for control and the second shall serve as a check on the first.

8.3 Deformation

Instrumentation for the measurement of deformation of the test specimen shall be located so as to provide data in terms of the amount and rate of deformation during and, where appropriate, subsequent to the fire test.

8.4 Integrity

Measurements of the integrity of the test specimen shall be made by either cotton wool pads or gap gauges, as appropriate to the nature and location of the opening (cotton wool pads may not be suitable for assessing integrity where significant gaps occur in the area of a negative pressure zone within the furnace, or where the assembly depicted by figure 5 may not be employed), as follows.

8.4.1 Cotton wool pad

A cotton wool pad is used by placing the frame within which it is mounted against the surface of the test specimen, adjacent to the opening or flaming under examination, for a period of 30 s or until ignition (defined as glowing or flaming) of the cotton wool pad occurs. Small adjustments in position may be made so as to achieve the maximum effect from the hot gases.

Where there are irregularities in the surface of the test specimen in the area of the opening, care shall be taken to ensure that the legs of the support frame are sufficient to maintain clearance between the pad and any part of the test specimen surface during the measurements.

The operator may make "screening tests" to evaluate the integrity of the test specimen. Such screening may involve selective short duration applications of the cotton pad to areas of potential failure and/or the movement of a single pad over and around such areas. Charring of the pad may provide an indication of imminent failure, but an unused pad shall be employed in the prescribed manner for an integrity failure to be confirmed.

For elements or parts of elements not fulfilling the insulation criteria, the cotton pad shall not be used when the temperature on the unexposed surface, in the vicinity of the opening, has exceeded 300 °C.

8.4.2 Gap gauges

Where gap gauges are used, the size of the opening in the surface of the test specimen shall be evaluated at intervals which will be determined by the apparent rate of the test specimen deterioration. Two gap gauges shall be employed, in turn, without undue force to determine

- a) whether the 6 mm gap gauge can be passed through the test specimen such that the gauge projects into the furnace, and can be moved a distance of 150 mm along the gap; or
- b) whether the 25 mm gap gauge can be passed through the test specimen such that the gauge projects into the furnace.

Any small interruption to the passage of the gauge that would have little or no effect upon the transmission of hot gases through the opening shall not be taken into account (e.g. small fastenings across a construction joint that has opened up due to distortion).

9 Test procedure

9.1 Restraint application

Depending upon its design, relevant restraint may be afforded by constructing the test specimen inside a rigid frame. This method shall be used for partitions and for certain types of floors, as appropriate. In such cases, any gaps between the edges of the test specimen and the frame shall be filled with rigid materials.

Restraint may also be applied by the use of hydraulic or other loading systems. The restraining forces and/or moments may be arranged so as to resist expansion, contraction or rotation. In such cases the values of these restraining forces and moments are useful information and should be measured at intervals throughout the test.

9.2 Load application

For loadbearing elements, the test load shall be applied at least 15 min before the commencement of the test and at such a rate that no dynamic effects are incurred. Relevant resulting deformations shall be measured. If the test specimen comprises materials which incur apparent deformations at the test load level, the applied load shall be held constant prior to fire testing until the deformations are stabilized. Following their application and during the course of the test, the loads shall be kept constant and when deformation of the test specimen takes place the loading system shall respond quickly to maintain a constant value.

If the test specimen has not collapsed and the heating is terminated, the load can be released immediately unless it is required to monitor the continuing ability of the test specimen to support the load. In the latter case the report shall clearly describe the cooling of the test specimen and whether this is achieved by artificial means, by removal from the furnace or by opening of the furnace.

9.3 Commencement of test

Not more than 5 min before the commencement of the test, the initial temperatures recorded by all thermocouples shall be checked to ensure consistency and the datum values shall be noted. Similar datum values shall be obtained for deformation and the initial condition of the test specimen shall be noted.

At the time of the test, the initial average internal temperature, if used, and unexposed surface temperature of the test specimen shall be $20\text{ }^{\circ}\text{C} \pm 10\text{ }^{\circ}\text{C}$ and shall be within $5\text{ }^{\circ}\text{C}$ of the initial ambient temperature (see 6.6).

Prior to the commencement of the test, the furnace temperature shall be less than $50\text{ }^{\circ}\text{C}$. The commencement of the test shall be considered to be the moment when the programme to follow the standard heating curve has been initiated. The elapsed time shall be measured from this point and all manual and automatic systems for measurement and observation shall begin or be in operation at this time, and the furnace shall be controlled to comply with the temperature conditions specified in 6.1.

9.4 Measurements and observations

From the commencement of the test, the following measurements and observations shall be taken, where relevant.

9.4.1 Temperatures

Temperatures of the fixed thermocouples (all except roving thermocouples) shall be measured and recorded at intervals not exceeding 1 min for the duration of the heating period.

The roving thermocouple shall be applied in accordance with the requirements of 8.1.3.

9.4.2 Furnace pressure

The furnace pressure shall be measured and recorded continuously or at intervals not exceeding 5 min at the control point.

9.4.3 Deformation

The relevant deformations of the test specimen shall be measured and recorded throughout the test. In the case of loadbearing test specimens, measurements shall be made prior to and following the application of the test load and at 1 min intervals during the heating period. The rate of deformation shall be calculated on the basis of these measurements.

- a) For horizontal loadbearing test specimens, the measurements shall be made at the location where the maximum deflections are expected to occur (for simply supported elements this is usually at mid span).
- b) For vertical loadbearing elements, elongation (which represents an increase in height of the test specimen) shall be expressed positively, and contraction (which results in a decrease in height of the test specimen) shall be expressed negatively.

9.4.4 Integrity

The integrity of the separating elements shall be evaluated throughout the test and the following shall be recorded.

- a) Cotton wool pad

Note the time of ignition (defined as glowing or flaming of a cotton wool pad, when applied in the manner specified in 8.4.1), together with the location at which ignition occurred (charring of the pad without flaming or glowing shall be ignored).

- b) Gap gauges

Note the time when it proves possible to enter a gap gauge into any opening in the test specimen in the manner specified in 8.4.2, together with the location of the opening;

- c) Flaming

Note the occurrence and duration of any flaming on the unexposed surface, together with the location of the flaming.

9.4.5 Load and restraints

For loadbearing elements, note shall be made of the time at which the test specimen is unable to support the test load. Any variation in measured forces and/or moments necessary to maintain an applied restraint condition shall be recorded.

9.4.6 General behaviour

Observations shall be made of the general behaviour of the test specimen during the course of the test and notes concerning phenomena such as deformation, cracking, melting or softening of the materials, spalling or charring, etc., of materials of construction of the test specimen shall be made. If quantities of smoke are emitted from the unexposed face, this shall be noted in the report.

9.5 Termination of test

The test may be terminated for one or more of the following reasons:

- a) safety of personnel or impending damage to equipment;
- b) attainment of selected criteria;
- c) request of the sponsor.

The test may be continued after failure under b) to obtain additional data.

10 Performance criteria

10.1 General

This clause describes the performance criteria which shall be considered in assessing the fire resistance of various forms of building construction which have been subjected to the standard fire test. Special requirements may be in addition to the general performance criteria or may vary as a function of the specific type of element of building construction.

Fire resistance is the period for which the test specimen has demonstrated compliance with these performance criteria, which are designed to measure the stability of a loadbearing construction and the effectiveness as a barrier of a separating construction. Where the test specimen represents building construction which is intended to perform both of these functions, its performance is judged on both aspects.

10.2 Specific performance criteria

The fire resistance of the test specimen shall be judged against one or more of the following performance criteria, as appropriate.

For certain elements of building construction, other special criteria may be required in the particular standards.

10.2.1 Loadbearing capacity

This is the elapsed time for which the test specimen continues to maintain its ability to support the test load during the test. Support of the test load is determined by both the amount and the rate of deflection. Since relatively rapid deflections can occur until stable conditions are reached, the rate of deflection criteria is not applied until a deflection of $L/30$ has been exceeded.

For the purposes of this part of ISO 834, failure to support the load is deemed to have occurred when both of the following criteria have been exceeded.

- a) For flexural elements:

$$\text{Limiting deflection, } D = \frac{L^2}{400 d} \text{ mm; and}$$

$$\text{Limiting rate of deflection, } \frac{dD}{dt} = \frac{L^2}{9\,000 d} \text{ mm/min;}$$

where

L is the clear span of the test specimen, in millimetres;

d is the distance from the extreme fibre of the design compression zone to the extreme fibre of the design tensile zone of the structural section, in millimetres.

- b) For axially loaded elements:

$$\text{Limiting axial contraction, } C = \frac{h}{100} \text{ mm; and}$$

$$\text{Limiting rate of axial contraction, } \frac{dC}{dt} = \frac{3h}{1\,000} \text{ mm/min;}$$

where h is the initial height, in millimetres.

10.2.2 Integrity

This is the elapsed time for which the test specimen continues to maintain its separating function during the test without either

- a) causing the ignition of a cotton pad applied in accordance with 8.4.1; or
- b) permitting the penetration of a gap gauge as specified in 8.4.2; or
- c) resulting in sustained flaming on the unexposed surface in excess of 10 s duration.

10.2.3 Insulation

This is the elapsed time for which the test specimen continues to maintain its separating function during the test without developing temperatures on its unexposed surface which either

- a) increase the average temperature above the initial average temperature by more than 140 K; or
- b) increase above the initial temperature at any location (including the roving thermocouple) by more than 180 K (the initial temperature shall be the average unexposed face temperature at the commencement of the test).

11 Validity of the test

The test will be considered to be valid if it has been conducted within all of the specified limits of the requirements pertaining to the test equipment, test conditions, test specimen preparation, instrument application and test procedure, according to this part of ISO 834.

The test may also be considered for acceptance if the fire exposure conditions relating to furnace temperature, pressure and ambient temperature are in excess of the upper limit of the tolerances specified in clause 6.

12 Expression of test results

12.1 Fire resistance

The fire resistance of the test specimen shall be given as completed elapsed minutes for which the relevant performance criteria have been satisfied.

12.2 Performance criteria

12.2.1 Insulation and integrity versus loadbearing capacity

The performance criteria “insulation” and “integrity” shall automatically be assumed not to be satisfied when the “loadbearing capacity” criterion is not satisfied.

12.2.2 Insulation versus integrity

The performance criteria “insulation” shall automatically be assumed not to be satisfied when the “integrity” criterion is not satisfied.

12.3 Termination prior to failure

When a test has been terminated prior to failure under all of the relevant performance criteria, the reason for termination shall be stated. The result shall be given as the time of termination of the test and shall be qualified accordingly.

12.4 Expression of test result

An example of the method of expressing the test results is given below for a loadbearing separating element, where the integrity and insulation criteria were exceeded and the test was discontinued at the request of the sponsor before the collapse of the test specimen.

| | |
|-----------------------|--|
| “Loadbearing capacity | ≥ 128 min (the test having been discontinued at the request of the sponsor); |
| Integrity | 120 min; |
| Insulation | 110 min”. |

NOTE — If the cotton pad was not used because of high temperatures on the unexposed face of the test specimen, the time to this situation should be stated.

13 Test report

The test report shall carry the following statement in a prominent position.

“This report provides the constructional details, the test conditions and the results obtained when a specific element of construction was tested following the procedure specified in ISO 834-1. Any significant deviation with respect to size, constructional details, loads, stresses, edge or end conditions may invalidate the test results.”

The test report shall include all important information relevant to the test specimen and the fire test including the following specific items and those items required by the test standards for the individual elements:

- a) the name and address of the testing laboratory, any unique reference number and the test date;
- b) the name(s) and address(es) of the sponsor, the product(s) and the manufacturer(s) of the test specimen and any of its component parts, if known; if unknown, this shall be stated;
- c) the assembly procedure and constructional details of the test specimen, with drawings including the dimensions of components and, where possible, photographs;
- d) the relevant properties of materials used that have a bearing on the fire performance of the test specimen together with the method of their determination, including, for example, information concerning moisture content and conditioning where appropriate;
- e) for loadbearing elements, the load applied to the test specimen and the basis for its calculation;
- f) the support and restraint conditions used and the rationale for their selection;
- g) information concerning the location of all thermocouples, deformation and pressure measuring devices, together with a graphical and/or tabular depiction of data obtained from these devices during the test;
- h) a description of significant behaviour of the test specimen during the test period, together with the determination, on the basis of the criteria in clause 10, of the end point of the test;
- i) the fire resistance of the test specimen expressed as specified in clause 12;
- j) for asymmetrical separating elements, the direction in which the test specimen was tested and the validity of the test result if the structure is exposed to fire on the opposite side.