

มาตรฐานผลิตภัณฑ์อุตสาหกรรม

THAI INDUSTRIAL STANDARD

มอก. 1458–2552

IEC 61000–4–9(2001–03)

# ความเข้ากันได้ทางแม่เหล็กไฟฟ้า

เล่ม 4 เทคนิคการทดสอบและการวัด

ส่วนที่ 9 การทดสอบภูมิคุ้มกันสนามแม่เหล็กที่เป็นพัลส์

ELECTROMAGNETIC COMPATIBILITY (EMC)

PART 4: TESTING AND MEASUREMENT TECHNIQUES

SECTION 9: PULSE MAGNETIC FIELD IMMUNITY TEST

สำนักงานมาตรฐานผลิตภัณฑ์อุตสาหกรรม

กระทรวงอุตสาหกรรม

ICS 33.100.20

ISBN 978-616-231-258-8

มาตรฐานผลิตภัณฑ์อุตสาหกรรม  
ความเข้ากันได้ทางแม่เหล็กไฟฟ้า

เล่ม 4 เทคนิคการทดสอบและการวัด  
ส่วนที่ 9 การทดสอบภูมิคุ้มกันสนามแม่เหล็กที่เป็นพัลส์

มอก. 1458 – 2552

สำนักงานมาตรฐานผลิตภัณฑ์อุตสาหกรรม  
กระทรวงอุตสาหกรรม ถนนพระรามที่ 6 กรุงเทพฯ 10400  
โทรศัพท์ 02 202 3300

ประกาศในราชกิจจานุเบกษา ฉบับประกาศและงานทั่วไป เล่ม 126 ตอนพิเศษ 188ง  
วันที่ 29 ธันวาคม พุทธศักราช 2552

มาตรฐานผลิตภัณฑ์อุตสาหกรรมความเข้ากันได้ทางแม่เหล็กไฟฟ้า เล่ม 4 เทคนิคการทดสอบและการวัด ส่วนที่ 9 การทดสอบภูมิคุ้มกันสนามแม่เหล็กที่เป็นพัลส์ ได้ประกาศใช้ครั้งแรกโดยรับ IEC 1000-4-9(1993-06) Electromagnetic compatibility (EMC) – Part 4: Testing and measurement techniques – Section 9: Pulse magnetic field immunity test มาใช้ในระดับเหมือนกันทุกประการ (Identical) โดยใช้ IEC ฉบับภาษาอังกฤษเป็นหลัก โดยประกาศในราชกิจจานุเบกษา ฉบับประกาศทั่วไป เล่มที่ 115 ตอนที่ 31ง วันที่ 16 เมษายน พุทธศักราช 2541 เนื่องจาก IEC ได้แก้ไขปรับปรุงมาตรฐาน IEC 1000-4-9(1993-06) เป็น IEC 61000-4-9 (2001-03) จึงได้ยกเลิกมาตรฐานเดิมและกำหนดมาตรฐานใหม่โดยรับ IEC 61000-4-9 (2001-03) Electromagnetic Compatibility (EMC) Part 4-9: Testing and measurement techniques- Pulse magnetic field immunity test มาใช้ในระดับเหมือนกันทุกประการโดยใช้มาตรฐาน IEC ฉบับภาษาอังกฤษเป็นหลัก

คณะกรรมการมาตรฐานผลิตภัณฑ์อุตสาหกรรมได้พิจารณามาตรฐานนี้แล้ว เห็นสมควรเสนอรัฐมนตรีประกาศตาม มาตรา 15 แห่งพระราชบัญญัติมาตรฐานผลิตภัณฑ์อุตสาหกรรม พ.ศ. 2511



**ประกาศกระทรวงอุตสาหกรรม**

**ฉบับที่ 4076 ( พ.ศ. 2552 )**

ออกตามความในพระราชบัญญัติมาตรฐานผลิตภัณฑ์อุตสาหกรรม

พ.ศ. 2511

เรื่อง ยกเลิกและกำหนดมาตรฐานผลิตภัณฑ์อุตสาหกรรม

ความเข้ากันได้ทางแม่เหล็กไฟฟ้า

เล่ม 4 เทคนิคการทดสอบและการวัด

ส่วนที่ 9 การทดสอบภูมิคุ้มกันสนามแม่เหล็กที่เป็นพัลส์

โดยที่เป็นการสมควรปรับปรุงมาตรฐานผลิตภัณฑ์อุตสาหกรรม ความเข้ากันได้ทางแม่เหล็กไฟฟ้า เล่ม 4 เทคนิคการทดสอบและการวัด ส่วนที่ 9 การทดสอบภูมิคุ้มกันสนามแม่เหล็กที่เป็นพัลส์ มาตรฐานเลขที่ มอก.1458-2540

อาศัยอำนาจตามความในมาตรา 15 แห่งพระราชบัญญัติมาตรฐานผลิตภัณฑ์อุตสาหกรรม พ.ศ. 2511 รัฐมนตรีว่าการกระทรวงอุตสาหกรรมออกประกาศยกเลิกประกาศกระทรวงอุตสาหกรรม ฉบับที่ 2360 (พ.ศ.2541) ออกตามความในพระราชบัญญัติมาตรฐานผลิตภัณฑ์อุตสาหกรรม พ.ศ. 2511 เรื่อง กำหนดมาตรฐานผลิตภัณฑ์อุตสาหกรรม ความเข้ากันได้ทางแม่เหล็กไฟฟ้า เล่ม 4 เทคนิคการทดสอบและการวัด ส่วนที่ 9 การทดสอบภูมิคุ้มกันสนามแม่เหล็กที่เป็นพัลส์ ลงวันที่ 9 กุมภาพันธ์ พ.ศ. 2541 และออกประกาศกำหนดมาตรฐานผลิตภัณฑ์อุตสาหกรรม ความเข้ากันได้ทางแม่เหล็กไฟฟ้า เล่ม 4 เทคนิคการทดสอบและการวัด ส่วนที่ 9 การทดสอบภูมิคุ้มกันสนามแม่เหล็กที่เป็นพัลส์ มาตรฐานเลขที่ มอก.1458-2552 ขึ้นใหม่ ดังมีรายละเอียดต่อท้ายประกาศนี้

ทั้งนี้ให้มีผลตั้งแต่วันที่ถัดจากวันที่ประกาศในราชกิจจานุเบกษา เป็นต้นไป

ประกาศ ณ วันที่ 1 กันยายน พ.ศ. 2552

**ชาญชัย ชัยรุ่งเรือง**

รัฐมนตรีว่าการกระทรวงอุตสาหกรรม

# มาตรฐานผลิตภัณฑ์อุตสาหกรรม ความเข้ากันได้ทางแม่เหล็กไฟฟ้า

## เล่ม 4 เทคนิคการทดสอบและการวัด

### ส่วนที่ 9 การทดสอบภูมิคุ้มกันสนามแม่เหล็กที่เป็นพัลส์

มาตรฐานผลิตภัณฑ์อุตสาหกรรมนี้กำหนดขึ้นโดยรับ IEC 61000-4-9 (2001-03) Electromagnetic Compatibility (EMC) Part 4-9: Testing and measurement techniques- Pulse magnetic field immunity test มาใช้ในระดับเหมือนกันทุกประการ (identical) โดยใช้ IEC ฉบับภาษาอังกฤษเป็นหลัก

มาตรฐานผลิตภัณฑ์อุตสาหกรรมนี้เกี่ยวข้องกับคุณลักษณะที่ต้องการทางด้านภูมิคุ้มกันของผลิตภัณฑ์ต่อการรบกวนทางแม่เหล็กที่เป็นพัลส์ (เฉพาะภายใต้สภาวะการทำงาน) ซึ่งเกี่ยวข้องกับโรงงานอุตสาหกรรมและโรงงานผลิตไฟฟ้าหรือสถานไฟฟ้าย่อยแรงดันไฟฟ้าปานกลางและแรงดันไฟฟ้าสูง

ซึ่งเป็นการประยุกต์ใช้มาตรฐานนี้กับผลิตภัณฑ์ที่ติดตั้งในสถานที่ต่างกันถูกกำหนดโดยการแสดงออกของปรากฏการณ์ธรรมชาติที่ระบุไว้ในข้อ 3

มาตรฐานนี้ไม่ได้พิจารณาการรบกวนเนื่องจากการเชื่อมต่อเชิงความจุไฟฟ้าหรือเชิงเหนี่ยวนำไฟฟ้าในสายเคเบิลหรือส่วนอื่น ๆ ของสิ่งติดตั้งภาคสนาม

มาตรฐานอื่น IEC อื่น ๆ ซึ่งเกี่ยวข้องกับการรบกวนที่ถูกนำมาจะครอบคลุมปัญหาดังกล่าวนี้

วัตถุประสงค์ของมาตรฐานนี้เพื่อจัดตั้งพื้นฐานซึ่งใช้ร่วมกันและทำซ้ำสำหรับประเมินลักษณะสมบัติของผลิตภัณฑ์ไฟฟ้าและอิเล็กทรอนิกส์ สำหรับการใช้งานภายในที่อยู่อาศัย การพาณิชย์ และอุตสาหกรรม เมื่ออยู่ภายใต้สนามแม่เหล็กที่แกว่งหว่ง

มาตรฐานนี้ได้นิยาม

- ระดับการทดสอบที่แนะนำ
- วิธีการทดสอบ
- การจัดเครื่องมือทดสอบ
- กระบวนการทดสอบ

รายละเอียดให้เป็นไปตาม IEC 61000-4-9 (2001-03)

© IEC 2001

เอกสารนี้เป็นสิทธิ์ของ IEC หากมิได้กำหนดไว้เป็นอย่างอื่นห้ามนำมาตรฐานฉบับนี้หรือ  
ส่วนหนึ่งส่วนใดไปทำซ้ำหรือใช้ประโยชน์ในรูปแบบ หรือโดยวิธีใด ๆ ไม่ว่าจะในรูปแบบ  
อิเล็กทรอนิกส์หรือทางกล รวมถึงการถ่ายสำเนา ถ่ายไมโครฟิล์ม โดยไม่ได้รับอนุญาตเป็น  
ลายลักษณ์อักษรจาก IEC ตามที่อยู่ข้างล่างหรือจากสมาชิก IEC ในประเทศของผู้ร้องขอ

IEC Central office

3, rue de Varembe',

CH-1211 Geneva 20

Switzerland

E-mail : [inmail@iec.ch](mailto:inmail@iec.ch)

Web : [www.iec.ch](http://www.iec.ch)

## CONTENTS

	Page
FOREWORD.....	7
INTRODUCTION.....	11
Clause	
1 Scope .....	13
2 Normative references .....	13
3 General.....	15
4 Definitions.....	15
5 Test levels.....	17
6 Test equipment.....	17
6.1 Test generator.....	19
6.2 Induction coil.....	21
6.3 Test and auxiliary instrumentation.....	25
7 Test set-up.....	25
7.1 Ground (reference) plane.....	27
7.2 Equipment under test.....	27
7.3 Test generator.....	27
7.4 Induction coil.....	27
8 Test procedure .....	29
8.1 Laboratory reference conditions.....	29
8.2 Carrying out the test .....	29
9 Evaluation of test results .....	31
10 Test report .....	33
Annex A (normative) Induction coil calibration method.....	41
Annex B (normative) Characteristics of the induction coils .....	43
Annex C (informative) Selection of the test levels .....	55
Annex D (informative) Information on magnetic field strength.....	59
Figure 1 – Example of application of the test field by the immersion method.....	35
Figure 2 – Current waveform of the test generator for pulse magnetic field (6,4/16 µs).....	35
Figure 3 – Schematic circuit of the test generator for pulse magnetic field (6,4/16 µs).....	35
Figure 4 – Example of test set-up for table-top equipment .....	37
Figure 5 – Example of test set-up for floor-standing equipment.....	37
Figure 6 – Example of investigation of susceptibility to magnetic field by the proximity method .....	39
Figure 7 – Illustration of Helmholtz coils .....	39

	Page
Figure B.1 – Characteristics of the field generated by a square induction coil (1 m side) in its plane .....	47
Figure B.2 – 3 dB area of the field generated by a square induction coil (1 m side) in its plane .....	47
Figure B.3 – 3 dB area of the field generated by a square induction coil (1 m side) in the mean orthogonal plane (component orthogonal to the plane of the coil).....	49
Figure B.4 – 3 dB area of the field generated by two square induction coils (1 m side) 0,6 m spaced, in the mean orthogonal plane (component orthogonal to the plane of the coils) .....	49
Figure B.5 – 3 dB area of the field generated by two square induction coils (1 m side) 0,8 m spaced, in the mean orthogonal plane (component orthogonal to the plane of the coils) .....	51
Figure B.6 – 3 dB area of the field generated by a rectangular induction coil (1 m × 2,6 m) in its plane .....	51
Figure B.7 – 3 dB area of the field generated by a rectangular induction coil (1 m × 2,6 m) in its plane (ground plane as a side of the induction coil) .....	53
Figure B.8 – 3 dB area of the field generated by a rectangular induction coil (1 m × 2,6 m) with ground plane, in the mean orthogonal plane (component orthogonal to the plane of the coil).....	53
Table 1 – Test levels.....	17



INTERNATIONAL ELECTROTECHNICAL COMMISSION

---

**ELECTROMAGNETIC COMPATIBILITY (EMC) –  
Part 4-9: Testing and measurement techniques –  
Pulse magnetic field immunity test**

FOREWORD

- 1) The IEC (International Electrotechnical Commission) is a worldwide organization for standardization comprising all national electrotechnical committees (IEC National Committees). The object of the IEC is to promote international co-operation on all questions concerning standardization in the electrical and electronic fields. To this end and in addition to other activities, the IEC publishes International Standards. Their preparation is entrusted to technical committees; any IEC National Committee interested in the subject dealt with may participate in this preparatory work. International, governmental and non-governmental organizations liaising with the IEC also participate in this preparation. The IEC collaborates closely with the International Organization for Standardization (ISO) in accordance with conditions determined by agreement between the two organizations.
- 2) The formal decisions or agreements of the IEC on technical matters express, as nearly as possible, an international consensus of opinion on the relevant subjects since each technical committee has representation from all interested National Committees.
- 3) The documents produced have the form of recommendations for international use and are published in the form of standards, technical specifications, technical reports or guides and they are accepted by the National Committees in that sense.
- 4) In order to promote international unification, IEC National Committees undertake to apply IEC International Standards transparently to the maximum extent possible in their national and regional standards. Any divergence between the IEC Standard and the corresponding national or regional standard shall be clearly indicated in the latter.
- 5) The IEC provides no marking procedure to indicate its approval and cannot be rendered responsible for any equipment declared to be in conformity with one of its standards.
- 6) Attention is drawn to the possibility that some of the elements of this International Standard may be the subject of patent rights. The IEC shall not be held responsible for identifying any or all such patent rights.

International Standard IEC 61000-4-9 has been prepared by subcommittee 77B: High frequency phenomena, of IEC technical committee 77: Electromagnetic compatibility.

It forms section 9 of part 4 of IEC 61000. It has the status of a basic EMC publication in accordance with IEC Guide 107.

This consolidated version of IEC 61000-4-9 consists of the first edition (1993) [documents 77B(CO)8 and 77B(CO)14] and its amendment 1 (2000) [documents 77B/291+293/FDIS and 77B/298+300/RVD].

The technical content is therefore identical to the base edition and its amendment and has been prepared for user convenience.

It bears the edition number 1.1.

A vertical line in the margin shows where the base publication has been modified by amendment 1.

Annexes A and B form an integral part of this standard.

Annexes C and D are for information only.

The committee has decided that the contents of the base publication and its amendment will remain unchanged until 2002. At this date, the publication will be

- reconfirmed;
- withdrawn;
- replaced by a revised edition, or
- amended.

## INTRODUCTION

This standard is part of the IEC 61000 series, according to the following structure:

Part 1: General

- General considerations (introduction, fundamental principles)
- Definitions, terminology

Part 2: Environment

- Description of the environment
- Classification of the environment
- Compatibility levels

Part 3: Limits

- Emission limits
- Immunity limits (in so far as they do not fall under the responsibility of the product committees)

Part 4: Testing and measurement techniques

- Measurement techniques
- Testing techniques

Part 5: Installation and mitigation guidelines

- Installation guidelines
- Mitigation methods and devices

Part 9: Miscellaneous

Each part is further subdivided into sections which are to be published either as international standards or as technical reports.

These standards and reports will be published in chronological order and numbered accordingly.

This part is an international standard which gives immunity requirements and test procedures related to "pulse magnetic field".

## **ELECTROMAGNETIC COMPATIBILITY (EMC) –**

### **Part 4-9: Testing and measurement techniques –**

#### **Pulse magnetic field immunity test**

### **1 Scope**

This international standard relates to the immunity requirements of equipment, only under operational conditions, to pulse magnetic disturbances mainly related to:

- industrial installations and power plants;
- medium voltage and high voltage sub-stations.

The applicability of this standard to equipment installed in different locations is determined by the presence of the phenomenon, as specified in clause 3.

This standard does not consider disturbances due to capacitive or inductive coupling in cables or other parts of the field installation.

Other IEC standards dealing with conducted disturbances cover these aspects.

The object of this standard is to establish a common and reproducible basis for evaluating the performance of electrical and electronic equipment for household, commercial and industrial applications when subjected to pulse magnetic fields.

The standard defines:

- recommended test levels;
- test equipment;
- test set-up;
- test procedure.

### **2 Normative references**

The following normative documents contain provisions which, through reference in this text, constitute provisions of this section of IEC 61000-4. At the time of publication, the editions indicated were valid. All normative documents are subject to revision, and parties to agreements based on this section of IEC 61000-4 are encouraged to investigate the possibility of applying the most recent editions of the normative documents indicated below. Members of IEC and ISO maintain registers of currently valid International Standards.

IEC 60060-2:1973, *High-voltage test techniques – Part 2: Test procedures*

IEC 60068-1:1988, *Environmental testing – Part 1: General and guidance*

IEC 60469-1:1987, *Pulse techniques and apparatus – Part 1: Pulse terms and definitions*

### 3 General

The magnetic fields to which equipment is subjected may influence the reliable operation of equipment and systems.

The following tests are intended to demonstrate the immunity of equipment when subjected to impulse magnetic fields related to the specific location and installation condition of the equipment (e.g. proximity of equipment to the disturbance source).

Pulse magnetic fields are generated by lightning strokes on buildings and other metal structures including aerial masts, earth conductors and earth networks and by initial faults transients in L.V., M.V. and H.V. electrical systems.

In H.V. sub-stations, a pulse magnetic field may also be generated by the switching of H.V. bus-bars and lines by circuit breakers.

The test is mainly applicable to electronic equipment to be installed in electrical plants as well as in telecontrol centres. It is not relevant for distribution network equipment.

Possible other applications may be considered by the product committees.

The test field waveform is that of the standard current pulse, waveform 6,4/16  $\mu$ s.

NOTE The waveform 6,4/16  $\mu$ s according to IEC 60469-1 corresponds to the 8/20  $\mu$ s of IEC 60060-2.

### 4 Definitions

The following definitions and terms are used in this standard and apply to the restricted field of magnetic disturbances; not all of them are included in IEC 60050(161) [IEV].

#### 4.1

##### **EUT**

equipment under test

#### 4.2

##### **induction coil**

conductor loop of defined shape and dimensions, in which flows a current, generating a magnetic field of defined constancy in its plane and in the enclosed volume

#### 4.3

##### **induction coil factor**

ratio between the magnetic field strength generated by an induction coil of given dimensions and the corresponding current value; the field is that measured at the centre of the coil plane, without the EUT

#### 4.4

##### **immersion method**

method of application of the magnetic field to the EUT, which is placed in the centre of an induction coil (figure 1)

#### 4.5

##### **proximity method**

method of application of the magnetic field to the EUT, where a small induction coil is moved along the side of the EUT in order to detect particularly sensitive areas

#### 4.6

##### **ground (reference) plane (GRP)**

a flat conductive surface whose potential is used as a common reference for the magnetic field generator and the auxiliary equipment (the ground plane can be used to close the loop of the induction coil, as in figure 5)

[IEV 161-04-36, modified]

#### 4.7

##### **decoupling network, back filter**

electrical circuit intended to avoid reciprocal influence with other equipment not submitted to the magnetic field test

#### 4.8

##### **transient**

pertaining to or designating a phenomenon or a quantity which varies between two consecutive steady states during a time interval short compared with the time-scale of interest

[IEV 161-02-01]

## 5 Test levels

The preferential range of test levels is given in table 1.

The magnetic field strength is expressed in A/m; 1 A/m corresponds to a free space induction of 1,26  $\mu$ T.

**Table 1 – Test levels**

Level	Pulse magnetic field strength
	A/m (peak)
1	n.a. <sup>2)</sup>
2	n.a. <sup>2)</sup>
3	100
4	300
5	1000
X <sup>1)</sup>	special

NOTE 1 "x" is an open level. This level can be given in the product specification.  
NOTE 2 "n.a." = not applicable

Information on the selection of the test levels is given in annex C.

Information on actual levels is given in annex D.

## 6 Test equipment

The test magnetic field is obtained by a current flowing in an induction coil; the application of the test field to the EUT is by the *immersion method*.

An example of application of the immersion method is given in figure 1.

The test equipment includes the current source (test generator), the induction coil and auxiliary test instrumentation.

## 6.1 Test generator

The generator, with the output waveform corresponding to the test magnetic field, shall be able to deliver the required current in the induction coils specified in 6.2.

The generator power capability shall therefore be dimensioned by taking into account the coil impedance; the inductance may range from 2,5  $\mu\text{H}$  for the 1 m standard coil, to several  $\mu\text{H}$  (e.g. 6  $\mu\text{H}$ ) for a rectangular induction coil (1 m  $\times$  2,6 m, see 6.2).

The specifications of the generator are:

- current capability, determined by the maximum selected test level and induction coil factor (see 6.2.2 and annex A), ranging from 0,87  $\text{m}^{-1}$  (1 m standard coil for testing table-top or small equipment) to 0,66  $\text{m}^{-1}$  (rectangular induction coil, 1 m  $\times$  2,6 m, for testing floor-standing or large equipment);
- operability in short-circuit condition;
- low output terminal connected to the earth terminal (for connection to the safety earth of the laboratory);
- precautions to prevent the emission of large disturbances that may be injected in the power supply network or may influence the test results.

The characteristics and performances of the current source or test generator for the field considered in this standard are given in 6.1.1.

### 6.1.1 Characteristics and performances of the test generator

The test generator is a non-repetitive (single shot) pulse current generator with characteristics as follows:

#### *Specifications*

Rise time:	6,4 $\mu\text{s} \pm 30 \%$
Duration:	16 $\mu\text{s} \pm 30 \%$
Output current range:	100 A to 1 000 A, divided by the coil factor
Polarity:	positive and negative
Phase relationship with the power frequency:	synchronizable from 0° to 360° with 10° steps
Synchronization:	triggerable by external signal

A standard current pulse generator, e.g. the surge hybrid generator (waveform 1,2/50 – 6,4/16  $\mu\text{s}$ ), may be used.

NOTE The output current range for the standard coil is from 120 A to 1 200 A peak.

The waveform of the output current is given in figure 2.

The schematic circuit of the generator is given in figure 3.

### 6.1.2 Verification of the characteristics of the test generator

In order to compare the results for different test generators, the essential characteristics of the output current parameters shall be verified.

The output current shall be verified with the generator connected to the standard induction coil specified in 6.2.1 a); the connection shall be realized by twisted conductors or coaxial cable of up to 3 m length and suitable cross-section.

The emission of disturbances by the generator shall be verified (see 6.1).

The characteristics to be verified are:

- output current peak value;
- rise time;
- duration.

A 1,8 mm wire diameter (2,5 mm<sup>2</sup>) should be used for the loop for short-circuit current operation; however, the mechanical rigidity should be taken into account.

The verifications shall be carried out with a current probe and oscilloscope or other equivalent measurement instrumentation with 10 MHz minimum bandwidth.

The accuracy of the measurements shall be  $\pm 10$  %.

## 6.2 Induction coil

### 6.2.1 Characteristics of the induction coil

The induction coil, connected to the test generator previously defined (see 6.1.1), shall generate a field strength corresponding to the selected test level and the defined homogeneity.

The induction coil shall be made of copper, aluminium or any conductive non-magnetic material, of such cross-section and mechanical arrangement as to facilitate its stable positioning during the tests.

A same coil is suitable for the generation of the magnetic fields considered in this standard; it may be a "single turn" coil and shall have a suitable current capability, as may be necessary for the selected test level.

Multi-turn coils may be used in order to have a lower testing current.

The induction coil shall be adequately dimensioned to surround the EUT (three orthogonal positions).

Depending on the size of the EUT, induction coils of different dimensions may be used.

The dimensions recommended below are suitable for the generation of magnetic fields over the whole volume of the EUT's (*table-top equipment or floor-standing equipment*), with an acceptable variation of  $\pm 3$  dB.

The characteristics of induction coils in respect of the magnetic field distribution are given in annex B.

#### a) Induction coil for table-top equipment

The induction coil of standard dimensions for testing small equipment (e.g. computer monitors, watt-hour meters, transmitters for process control, etc.) has a square (or circular) form with 1 m side (or diameter), made of a conductor of relatively small cross-section.

The test volume of the standard square coil is 0,6 m  $\times$  0,6 m  $\times$  0,5 m (height).

A double coil of standard size (Helmholtz coil) could be used in order to obtain a field homogeneity better than 3 dB or for testing larger EUT's.



The double coil (Helmholtz coil) shall comprise of two or more series of turns, properly spaced (see figure 7, figure B.4, figure B.5).

The test volume of a double standard size coil, 0,8 m spaced, for a 3 dB homogeneity is 0,6 m × 0,6 m × 1 m (height).

For example, the Helmholtz coils, for a 0,2 dB inhomogeneity, have dimensions and separation distances as given in figure 7.

b) *Induction coil for floor-standing equipment*

Induction coils shall be made according to the dimensions of the EUT and the different field polarizations.

The coil shall be able to envelop the EUT; the coil dimensions shall be such as to give a minimum distance of coil conductors to EUT equal to 1/3 of the dimension of the EUT considered.

The coils shall be made of conductors of relatively small cross-section.

NOTE Due to the possible large dimensions of EUT's, the coils may be made of "C" or "T" sections in order to have sufficient mechanical rigidity.

The test volume is determined by the testing area of the coil (60 % × 60 % of each side) multiplied by a depth corresponding to 50 % of the shorter side of the coil.

**6.2.2 Calibration of the induction coil, coil factor**

In order to make it possible to compare the test results from different test equipment, the induction coils shall be calibrated in their operating condition, before conducting the test (without the EUT, in free space condition).

An induction coil of the correct dimensions for the EUT dimensions, shall be positioned at 1 m minimum distance from the wall of the laboratory and any magnetic material, by using insulating supports, and shall be connected to the test generator as prescribed in 6.1.2.

Appropriate magnetic field sensors (B.W. > 10 MHz), with dynamics and frequency response corresponding to the pulse field, shall be used to verify the magnetic field strength generated by the induction coil.

The field sensor shall be positioned at the centre of the induction coil (without the EUT) and with suitable orientation to detect the maximum value of the field.

The current in the induction coil shall be adjusted to obtain the field strength specified by the test level.

The calibration shall be carried out at power frequency: the current value that generates a given field strength shall be used for the pulse test of the present standard.

The calibration procedure shall be carried out with the test generator and induction coil.

The coil factor is determined (and verified) by the above procedure.

The coil factor gives the current value to be injected in the coil to obtain the required test magnetic field (H/I).

Information on the measurement of the test magnetic field is given in annex A.

### **6.3 Test and auxiliary instrumentation**

#### **6.3.1 Test instrumentation**

The test instrumentation includes:

- current measuring system (sensors and instrument) for setting and measuring the current injected in the induction coil;
- termination networks, back filters, etc., on power supply, control and signal lines.

The termination network gives a defined impedance of 50  $\Omega$  to earth for all the external circuits connected to the EUT terminals. It may be represented by the line impedance stabilization network for power supply circuits, coupling/decoupling network, or resistor-capacitor series for input/output control and signal circuits. These networks shall be described in the test plan.

The termination networks, back filters, etc. shall be compatible with the operating signals.

Back filters shall be used in the connections to the simulator (see 6.3.2).

The current measuring system is a calibrated current probe or shunt; the transient current measurement instrumentation shall have a bandwidth of 10 MHz.

The accuracy of the measurement instrumentation shall be  $\pm 10$  %.

#### **6.3.2 Auxiliary instrumentation**

The auxiliary instrumentation comprises a simulator and any other instrument necessary for the operation and verification of the EUT functional specifications.

## **7 Test set-up**

The test set-up comprises the following components:

- ground (reference) plane (GRP);
- equipment under test (EUT);
- test generator;
- induction coil;
- termination network, back filter.

Precautions shall be taken if the test magnetic field may interfere with the test instrumentation and other sensitive equipment in the vicinity of the test set-up.

Examples of test set-ups are given in the following figures:

Figure 4: Example of test set-up for table-top equipment

Figure 5: Example of test set-up for floor-standing equipment

### 7.1 Ground (reference) plane

The ground plane (GRP) shall be placed in the laboratory; the EUT and auxiliary test equipment shall be placed on it and connected to it.

The ground plane shall be a non-magnetic metal sheet (copper or aluminium) of 0,25 mm thickness; other metals may be used but in this case they shall have 0,65 mm minimum thickness.

The minimum size of the ground plane is 1 m × 1 m.

The final size depends on the dimensions of the EUT.

The ground plane shall be connected to the safety earth system of the laboratory.

### 7.2 Equipment under test

The equipment is configured and connected to satisfy its functional requirements. It shall be placed on the GRP with the interposition of a 0,1 m thickness insulating support (e.g. dry wood).

The equipment cabinets shall be connected to the safety earth directly on the GRP with a connection of minimum length via the earth terminal of the EUT.

The power supply, input and output circuits shall be connected to the sources of power supply, control and signals via the back filters.

The cables supplied or recommended by the equipment manufacturer shall be used. In absence of any recommendation, unshielded cables shall be adopted, of a type appropriate for the signals involved. All cables shall be exposed to the magnetic field for 1 m of their length.

The back filters shall be inserted in the circuits at 1 m cable lengths from the EUT and connected to the ground plane.

The input and output circuits, to the simulator, shall be provided with back filters in order to prevent interference to that equipment.

The communication lines (data lines) shall be connected to the EUT by the cables given in the technical specification or standard for this application. Each line, in the proximity of the EUT, shall be maintained at a distance of about 0,1 m from the GRP.

### 7.3 Test generator

The test generator shall be placed at less than 3 m distance from the induction coil.

One terminal of the generator shall be connected to the ground plane.

### 7.4 Induction coil

The induction coil, of the type specified in 6.2.1, shall enclose the EUT placed at its centre.

Different induction coils may be selected for testing in the different orthogonal directions, according to the general criteria specified in 6.2.1 a) and b).

Induction coils used in the vertical position (horizontal polarization of the field) can be bonded (at the foot of one vertical conductor) directly to the ground plane, which represents the low side of the coil, as a part of it. In this case, 0,1 m minimum distance from EUT to the ground plane is sufficient.

The induction coil shall be connected to the test generator in the same way as for the calibration procedure specified in 6.2.2.

The induction coil selected for the tests shall be specified in the test plan.

## **8 Test procedure**

The test procedure shall include:

- verification of the laboratory reference conditions;
- preliminary verification of the correct operation of the equipment;
- carrying out the test;
- evaluation of the test results.

### **8.1 Laboratory reference conditions**

In order to minimize the effect of environmental parameters on the test results, the test shall be carried out in climatic and electromagnetic reference conditions as specified in 8.1.1 and 8.1.2.

#### **8.1.1 climatic conditions**

Unless otherwise specified by the committee responsible for the generic or product standard, the climatic conditions in the laboratory shall be within any limits specified for the operation of the EUT and the test equipment by their respective manufacturers.

Tests shall not be performed if the relative humidity is so high as to cause condensation on the EUT or the test equipment.

NOTE Where it is considered that there is sufficient evidence to demonstrate that the effects of the phenomenon covered by this standard are influenced by climatic conditions, this should be brought to the attention of the committee responsible for this standard.

#### **8.1.2 Electromagnetic conditions**

The electromagnetic conditions of the laboratory shall be such as to guarantee the correct operation of the EUT in order not to influence the test results; otherwise, the tests shall be carried out in a Faraday cage.

In particular, the electromagnetic field value of the laboratory shall be at least 20 dB lower than the selected test level.

### **8.2 Carrying out the test**

The test shall be carried out on the basis of a test plan including verification of the performances of the EUT as defined in the technical specification.

The power supply, signal and other functional electrical quantities shall be applied within their rated range.

If the actual operating signals are not available, they may be simulated.

Preliminary verification of equipment performances shall be carried out prior to applying the test magnetic field.

The test magnetic field shall be applied by the immersion method to the EUT, previously set up as specified in 7.2.

The test level shall not exceed the product specification.

NOTE In order to detect the most susceptible side/positions of the EUT, mainly of a stationary type, the proximity method may be used for investigation purposes. This method is not to be used for certification. An example of application of the test field by proximity method is given in figure 6.

The test is performed by applying at least 5 pulses of positive and 5 pulses of negative polarity.

The time interval between pulses shall be no less than 10 s.

a) *Table-top equipment*

The equipment shall be subjected to the test magnetic field by using the induction coil of standard dimensions (1 m × 1 m) specified in 6.2.1 a) and shown in figure 4.

The induction coil shall then be rotated by 90° in order to expose the EUT to the test field with different orientations.

b) *Floor-standing equipment*

The equipment shall be subjected to the test magnetic field by using induction coils of suitable dimensions as specified in 6.2.1 b); the test shall be repeated by moving and shifting the induction coils, in order to test the whole volume of the EUT for each orthogonal direction.

The test shall be repeated with the coil shifted to different positions along the side of the EUT, in steps corresponding to 50 % of the shortest side of the coil.

NOTE The moving of the induction coil in steps corresponding to 50 % of the shortest side of the coil gives overlapping test fields.

The induction coil shall then be rotated by 90° in order to expose the EUT to the test field with different orientations and the same procedure.

## 9 Evaluation of test results

The test results shall be classified in terms of the loss of function or degradation of performance of the equipment under test, relative to a performance level defined by its manufacturer or the requestor of the test, or agreed between the manufacturer and the purchaser of the product. The recommended classification is as follows:

- a) normal performance within limits specified by the manufacturer, requestor or purchaser;
- b) temporary loss of function or degradation of performance which ceases after the disturbance ceases, and from which the equipment under test recovers its normal performance, without operator intervention;
- c) temporary loss of function or degradation of performance, the correction of which requires operator intervention;
- d) loss of function or degradation of performance which is not recoverable, owing to damage to hardware or software, or loss of data.

The manufacturer's specification may define effects on the EUT which may be considered insignificant, and therefore acceptable.

This classification may be used as a guide in formulating performance criteria, by committees responsible for generic, product and product-family standards, or as a framework for the agreement on performance criteria between the manufacturer and the purchaser, for example where no suitable generic, product or product-family standard exists.

## 10 Test report

The test report shall contain all the information necessary to reproduce the test. In particular, the following shall be recorded:

- the items specified in the test plan required by clause 8 of this standard;
- identification of the EUT and any associated equipment, for example, brand name, product type, serial number;
- identification of the test equipment, for example, brand name, product type, serial number;
- any special environmental conditions in which the test was performed, for example, shielded enclosure;
- any specific conditions necessary to enable the test to be performed;
- performance level defined by the manufacturer, requestor or purchaser;
- performance criterion specified in the generic, product or product-family standard;
- any effects on the EUT observed during or after the application of the test disturbance, and the duration for which these effects persist;
- the rationale for the pass/fail decision (based on the performance criterion specified in the generic, product or product-family standard, or agreed between the manufacturer and the purchaser);
- any specific conditions of use, for example cable length or type, shielding or grounding, or EUT operating conditions, which are required to achieve compliance.

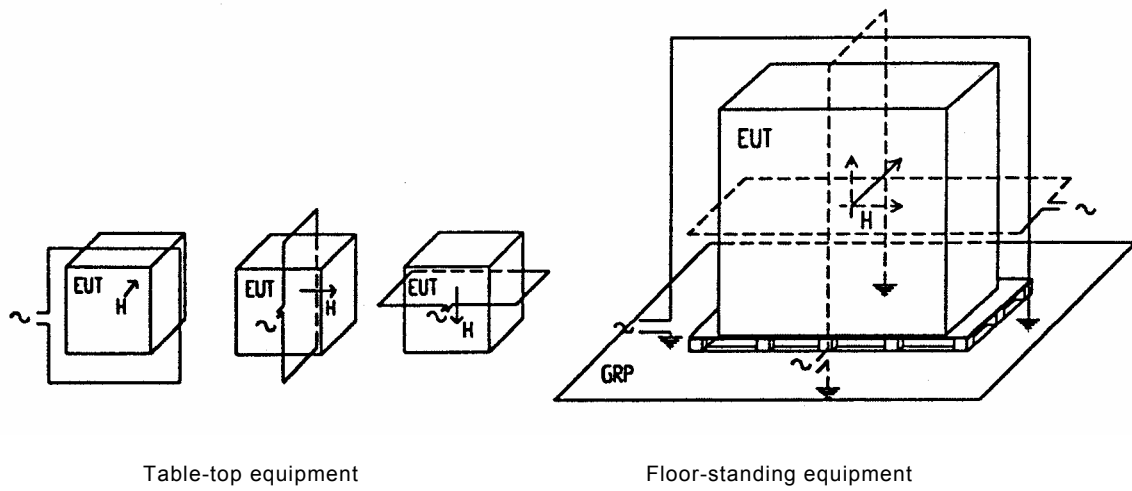

Figure 1 – Example of application of the test field by the immersion method

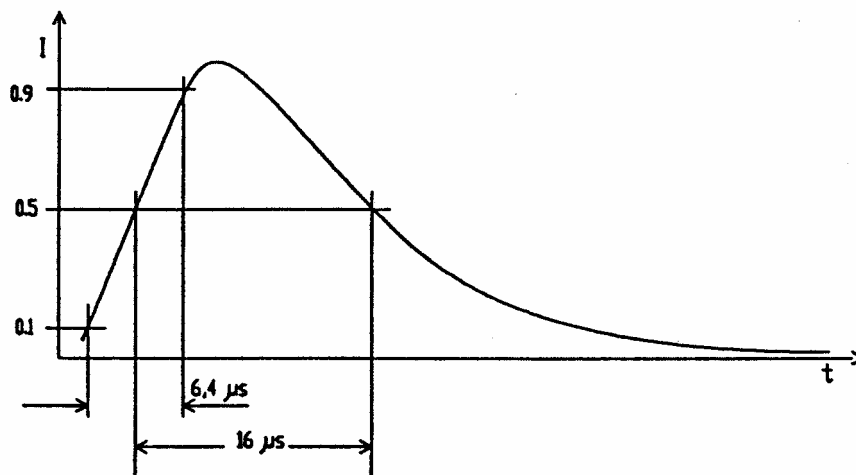
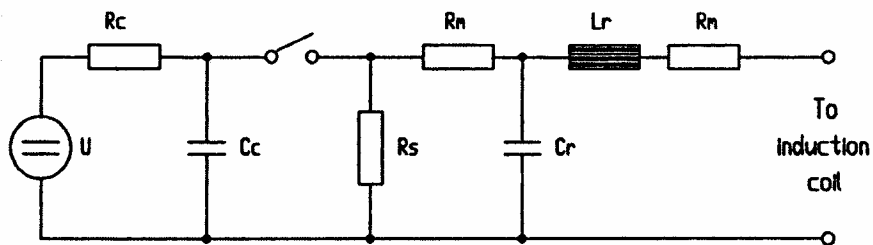

Figure 2 – Current waveform of the test generator for pulse magnetic field (6,4/16 μs)



- |                              |  |
|------------------------------|--|
| U: High voltage source       | Lr: Rise time shaping resistor             |
| Rc: Charging resistor        | Rm: Impedance matching resistor            |
| Cc: Energy storage capacitor | Rs1, Rs2: Pulse duration shaping resistors |

Figure 3 – Schematic circuit of the test generator for pulse magnetic field (6,4/16 μs)

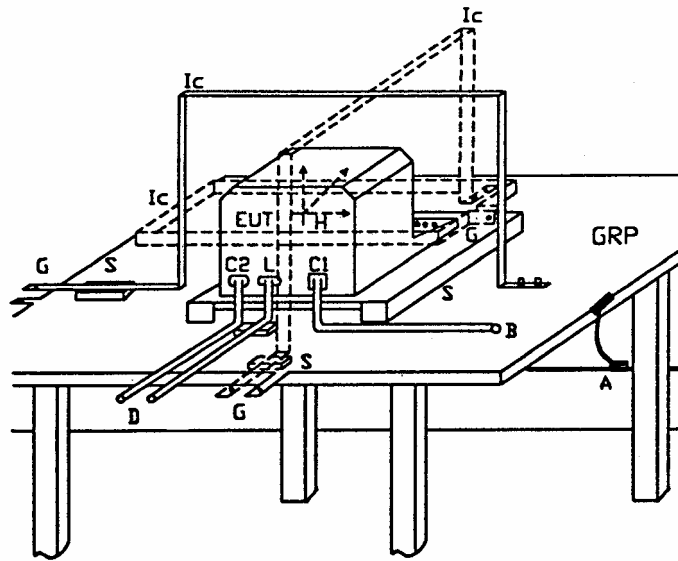

Figure 4 – Example of test set-up for table-top equipment

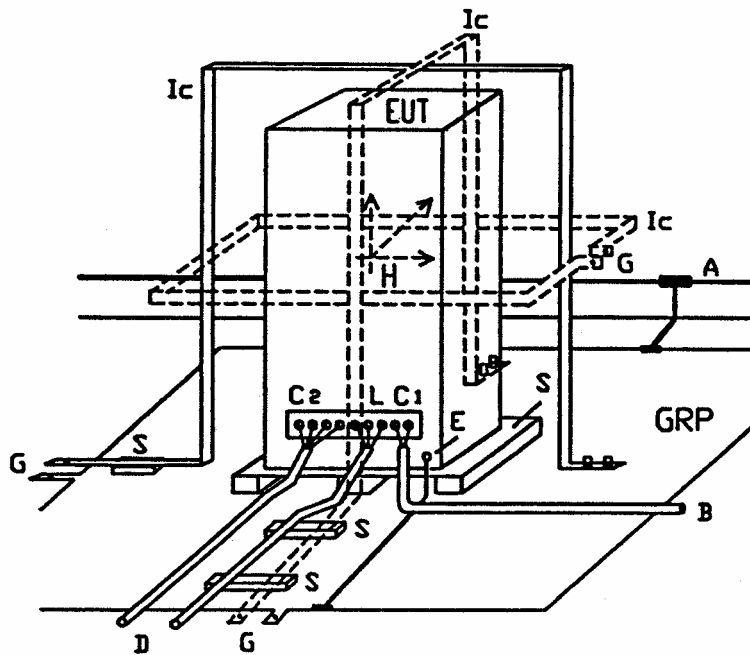

Figure 5 – Example of test set-up for floor-standing equipment

*References common to figure 4 and figure 5*

GRP: Ground plane	C1: Power supply circuit
A: Safety earth	C2: Signal circuit
S: Insulating support	L: Communication line
EUT: Equipment under test	B: To power supply source
Ic: Induction coil	D: To signal source, simulator
E: Earth terminal	G: To the test generator



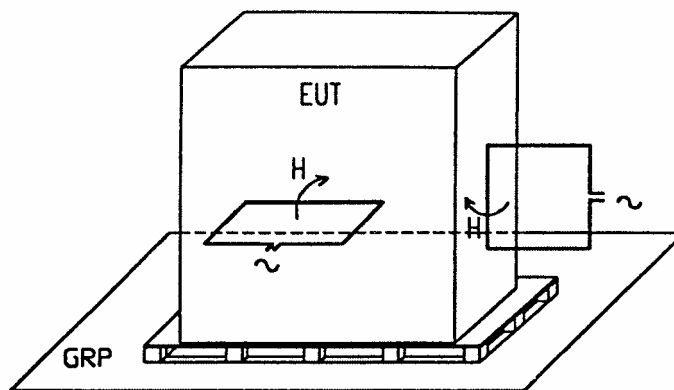
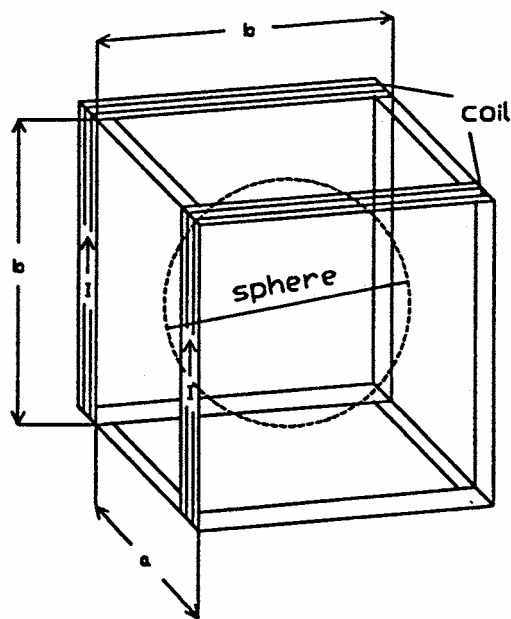

Figure 6 – Example of investigation of susceptibility to magnetic field by the proximity method



- |                                  |                               |
|----------------------------------|-------------------------------|
| n: Number of turns in each coil  | a: Separation of the coils    |
| b: Side of the coils (m)         | I: Current value (A)          |
| H: Magnetic field strength (A/m) | H: $1,22 \times n/b \times I$ |
- (with  $a = b/2,5$  the non-homogeneity of the magnetic field strength is  $\pm 0,2$  dB)

Figure 7 – Illustration of Helmholtz coils

## **Annex A** (normative)

### **Induction coil calibration method**

#### **A.1 Magnetic field measurement**

The magnetic field test is related to free space condition, without the EUT and at 1 m minimum distance from the laboratory walls and any magnetic material.

The measurement of the magnetic field may be done with a measurement system comprising wide band sensors (10 MHz minimum bandwidth, available in the market) and recording instruments e.g. transient recorders or storage oscilloscopes.

#### **A.2 Calibration of the induction coil**

The calibration shall be carried out by injecting the calibration current at power frequency in the induction coil and measuring the magnetic field by sensors placed at its geometrical centre.

Proper orientation of the sensor shall be selected in order to obtain the maximum value.

The "*induction coil factor*" shall be determined for each induction coil as the ratio "field strength/current of injection" (H/A).

The "coil factor", determined at a.c. current, is not related to the current waveform, because it is a characteristic parameter of the induction coil; it is therefore applicable for the evaluation of magnetic field at power frequency and other frequencies defined in this standard.

For standard dimension coil, the coil factor is determined by the manufacturer of the coil, and can be verified by laboratory measurements before carrying out the tests.

## **Annex B** (normative)

### **Characteristics of the induction coils**

#### **B.1 General**

This annex considers the problems of generation of the test magnetic fields.

In the first stage, both the immersion and proximity methods were considered.

In order to know the limits of application of such methods, some questions have been emphasized.

In the following the reasons for the values are explained.

#### **B.2 Induction coil requirements**

The requirement of the induction coil is "*3 dB tolerance of the test field in the volume of the EUT*"; this tolerance has been considered a reasonable technical compromise in respect of a test characterized by severity levels in 10 dB steps, due to practical limits in the generation of constant field over a wide range of volumes.

The constancy of the field is a requirement limited to a single direction, orthogonal to the coil plane. The field in different directions is obtainable in successive test steps by rotating the induction coil.

#### **B.3 Induction coil characteristics**

The characteristics of induction coils of different dimensions suitable for testing *table-top equipment* or *floor-standing equipment* are given in diagrams showing:

- profile of the field generated by a square induction coil (1 m side) in its plane (see figure B.1);
- 3 dB area of the field generated by a square induction coil (1 m side) in its plane (see figure B.2);
- 3 dB area of the field generated by a square induction coil (1 m side) in the mean orthogonal plane (component orthogonal to the plane of the coil) (see figure B.3);
- 3 dB area of the field generated by two square induction coils (1 m side) 0,6 m spaced, in the mean orthogonal plane (component orthogonal to the plane of the coils) (see figure B.4);
- 3 dB area of the field generated by two square induction coils (1 m side) 0,8 m spaced, in the mean orthogonal plane (component orthogonal to the plane of the coils) (see figure B.5);
- 3 dB area of the field generated by a rectangular induction coil (1 m × 2,6 m) in its plane (see figure B.6);
- 3 dB area of the field generated by a rectangular induction coil (1 m × 2,6 m) in its plane (ground plane as a side of the induction coil) (see figure B.7);

- 3 dB area of the field generated by a rectangular induction coil (1 m × 2,6 m), with ground plane, in the mean orthogonal plane (component orthogonal to the plane of the coil) (see figure B.8).

*In the selection of the form, arrangement and dimensions of the test coil, the following points have been considered:*

- the 3 dB area, inside and outside the induction coil, is related to the shape and dimensions of the induction coil;
- for a given field strength, driving current value, power and energy of the test generator are proportional to the dimensions of the induction coil.

#### **B.4 Summary of characteristics of induction coils**

On the basis of the data on the field distribution of coils with different sizes and in view of adopting the test method given in this standard to different classes of equipment, the conclusions that can be drawn are as follows:

- *single square coil, 1 m side:* testing volume 0,6 m × 0,6 m × 0,5 m high (0,2 m minimum distance from EUT to the coil);
- *double square coils, 1 m side, 0,6 spaced:* testing volume 0,6 × 0,6 × 1 m high (0,2 m minimum distance from EUT to the coil); increasing of the separation of the coils up to 0,8 m, extends the maximum high of testable EUT (see the 3 dB area, in the mean orthogonal plane) up to 1,2 m.
- *single rectangular coil, 1 m × 2,6 m:* testing volume 0,6 m × 0,6 m × 2 m high (0,2 and 0,3 m minimum distance from EUT to the coil, respectively for the horizontal and vertical dimensions of EUT); if the induction coil is bonded to the GRP, a 0,1 m distance from it is sufficient.

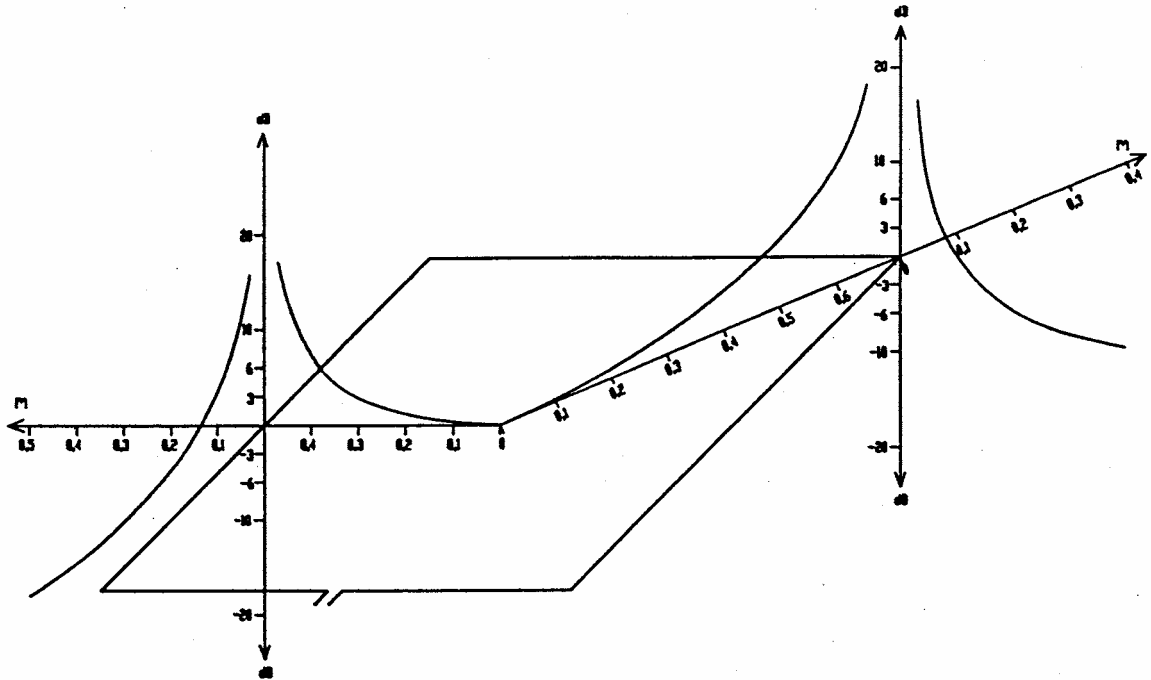

Figure B.1 – Characteristics of the field generated by a square induction coil (1 m side) in its plane

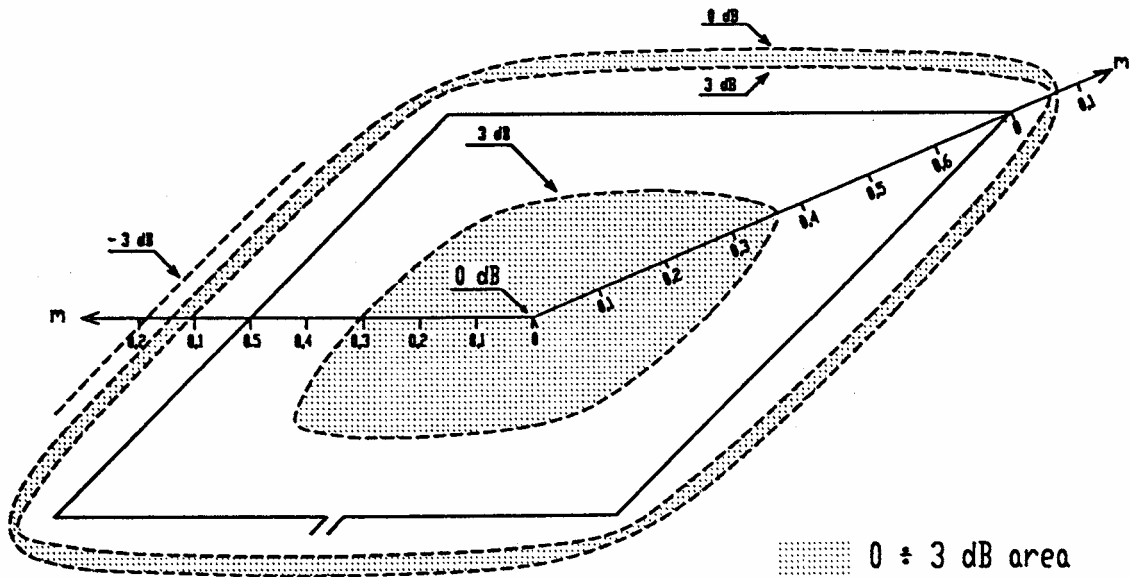

Figure B.2 – 3 dB area of the field generated by a square induction coil (1 m side) in its plane

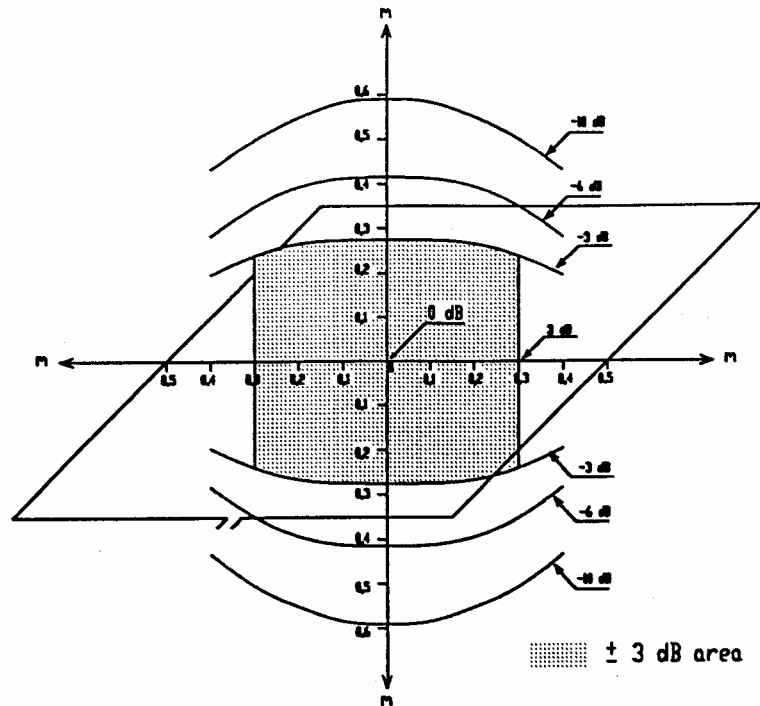

Figure B.3 – 3 dB area of the field generated by a square induction coil (1 m side) in the mean orthogonal plane (component orthogonal to the plane of the coil)

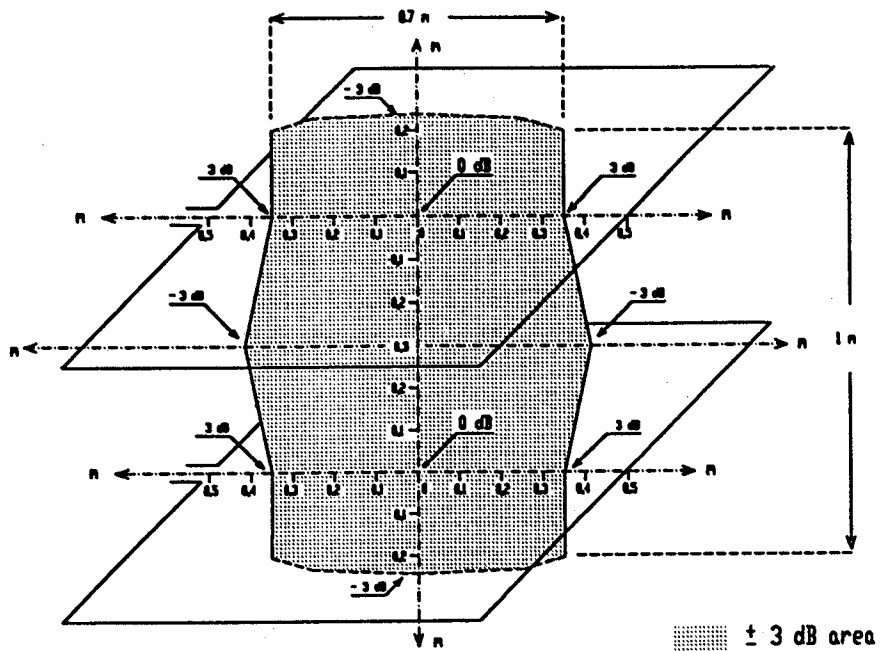

Figure B.4 – 3 dB area of the field generated by two square induction coils (1 m side) 0,6 m spaced, in the mean orthogonal plane (component orthogonal to the plane of the coils)

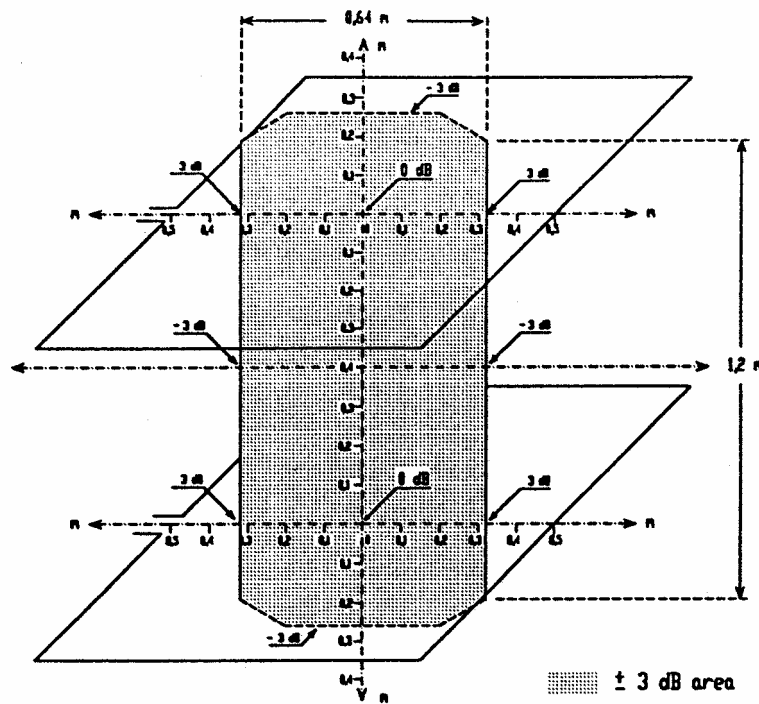

Figure B.5 – 3 dB area of the field generated by two square induction coils (1 m side) 0,8 m spaced, in the mean orthogonal plane (component orthogonal to the plane of the coils)

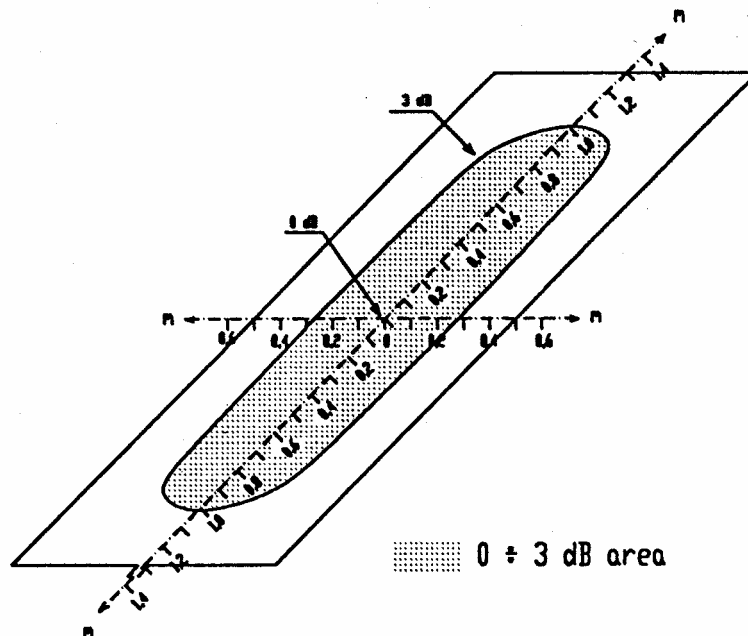

Figure B.6 – 3 dB area of the field generated by a rectangular induction coil (1 m x 2,6 m) in its plane

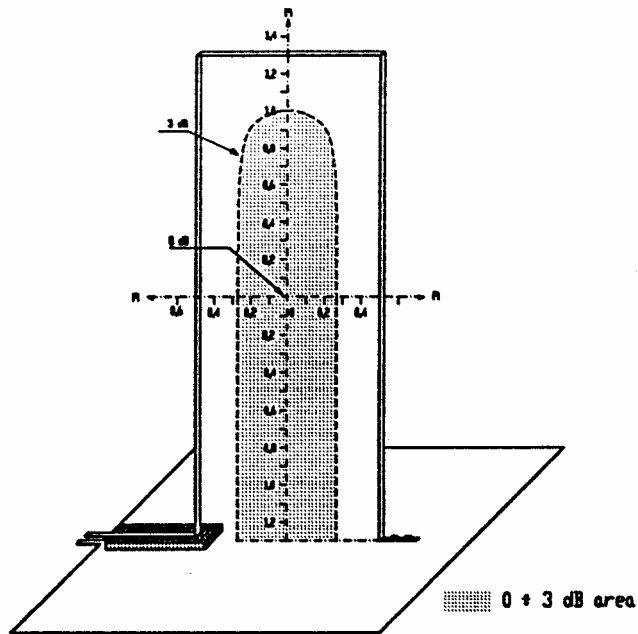

Figure B.7 – 3 dB area of the field generated by a rectangular induction coil (1 m × 2,6 m) in its plane (ground plane as a side of the induction coil)

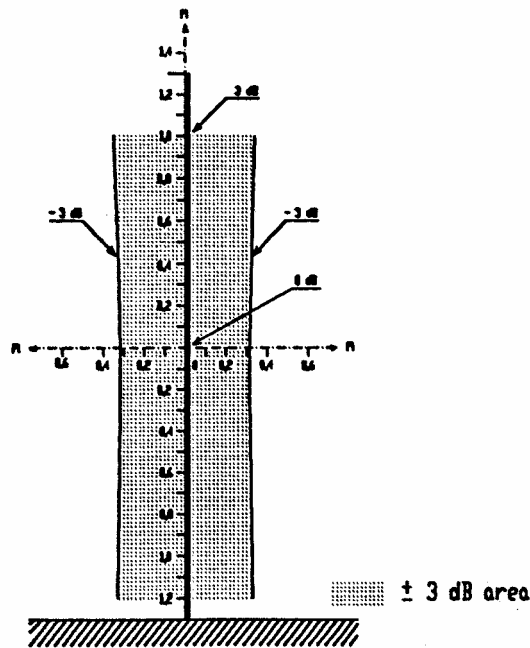

Figure B.8 – 3 dB area of the field generated by a rectangular induction coil (1 m × 2,6 m) with ground plane, in the mean orthogonal plane (component orthogonal to the plane of the coil)



## Annex C (informative)

### Selection of the test levels

The test levels shall be selected in accordance with the most realistic installation and environmental conditions.

These levels are outlined in clause 5.

The immunity tests are correlated with these levels in order to establish a performance level for the environment in which the equipment is expected to operate.

The test level shall be chosen according to:

- the electromagnetic environment;
- the proximity of the disturbances sources to the equipment concerned;
- the compatibility margins.

Based on common installation practices, a guide for the selection of test levels for pulse magnetic fields testing may be the following:

**Class 1:** Test not applicable to this environment where sensitive devices using electron beam can be used (*monitors, electron microscope, etc.*, are representative of these devices).

**Class 2:** Well protected environment

Test not applicable to this environment because the areas concerned are not subjected to the influence of lightning and initial transient fault current.

*Residential, office, hospital protected areas* far away from earth conductors of lightning protection systems may be representative of this environment.

**Class 3:** Protected environment

The environment is characterized by the proximity of earth conductors of lightning protection systems and metallic structures.

*Commercial areas, control building, field of not heavy industrial plants* provided with lightning protection system or metallic structures in the proximity, *computer room of H.V. sub-stations* may be representative of this environment.

**Class 4:** Typical industrial environment

The environment is characterized by the ground conductors of the lightning protection system or structures.

*Fields of heavy industrial and power plants* and the *control room of H.V. sub-stations* may be representative of this environment.

**Class 5:** Severe industrial environment

The environment is characterized by the following attributes:

- conductors, bus-bars or M.V., H.V. lines carrying tens of kA;
- ground conductors of the lightning protection system or high structures like the line towers carrying the whole lightning current.

*Switchyard areas of heavy industrial plants, M.V., H.V. and power stations* may be representative of this environment.

**Class X:** Special environment

The minor or major electromagnetic separation of interference sources from equipment circuits, cables, lines etc., and the quality of the installations may require the use of a higher or lower environmental level than those described above.

It should be noted that the equipment lines of a higher level can penetrate a lower severity environment.

**Annex D**  
(informative)

**Information on magnetic field strength**

The magnetic field strength ranges from a few hundreds A/m (peak) up to the order of 1 kA/m (peak) in the proximity of earth conductors, intended for protection from lightning and metal structures involved in the conduction of such transient currents; lower field strength values are representative of environments for equipment and systems installed inside buildings.

---