

มาตรฐานผลิตภัณฑ์อุตสาหกรรม

THAI INDUSTRIAL STANDARD

มอก. 1460 – 2552

IEC 61000 – 4 – 11(2004 – 03)

ความเข้ากันได้ทางแม่เหล็กไฟฟ้า

เล่ม 4 เทคนิคการทดสอบและการวัด

ส่วนที่ 11 การทดสอบภูมิคุ้มกันเมื่อแรงดันไฟฟ้าดิ่งลง ขาดหายไปเป็นระยะเวลาสั้น ๆ และแปรเปลี่ยน

ELECTROMAGNETIC COMPATIBILITY (EMC)

PART 4 : TESTING AND MEASUREMENT TECHNIQUES

SECTION 11 : VOLTAGE DIPS, SHORT INTERRUPTIONS AND VOLTAGE
VARIATIONS IMMUNITY TESTS

สำนักงานมาตรฐานผลิตภัณฑ์อุตสาหกรรม

กระทรวงอุตสาหกรรม

ICS 33.100.20

ISBN 978-616-231-260-1

มาตรฐานผลิตภัณฑ์อุตสาหกรรม
ความเข้ากันได้ทางแม่เหล็กไฟฟ้า

เล่ม 4 เทคนิคการทดสอบและการวัด
ส่วนที่ 10 การทดสอบภูมิคุ้มกันเมื่อแรงดันไฟฟ้าลดลง ขาดหายไปเป็นระยะเวลาสั้น ๆ
และแปรเปลี่ยน

มอก. 1460 – 2552

สำนักงานมาตรฐานผลิตภัณฑ์อุตสาหกรรม
กระทรวงอุตสาหกรรม ถนนพระรามที่ 6 กรุงเทพฯ 10400
โทรศัพท์ 02 202 3300

ประกาศในราชกิจจานุเบกษา ฉบับประกาศและงานทั่วไป เล่ม 126 ตอนพิเศษ 188ง
วันที่ 29 ธันวาคม พุทธศักราช 2552

มาตรฐานผลิตภัณฑ์อุตสาหกรรมความเข้ากันได้ทางแม่เหล็กไฟฟ้า เล่ม 4 เทคนิคการทดสอบและการวัด ส่วนที่ 11 การทดสอบภูมิคุ้มกันเมื่อแรงดันไฟฟ้าตกลงขาดหายไปเป็นระยะเวลาสั้น ๆ และแปรเปลี่ยน ได้ประกาศใช้ครั้งแรกโดยรับ IEC 1000-4-11(1994-06) Electromagnetic compatibility (EMC) – Part 4: Testing and measurement techniques – Section 11: Voltage dips, short interruptions and voltage variations immunity tests มาใช้ในระดับเหมือนกันทุกประการ (Identical) โดยใช้ IEC ฉบับภาษาอังกฤษเป็นหลัก โดยประกาศในราชกิจจานุเบกษา ฉบับประกาศทั่วไป เล่มที่ 115 ตอนที่ 31ง วันที่ 16 เมษายน พุทธศักราช 2541

เนื่องจาก IEC ได้แก้ไขปรับปรุงมาตรฐาน IEC 1000-4-11(1994-06) เป็น IEC 61000-4-11 (2004-03) จึงได้ยกเลิกมาตรฐานเดิมและกำหนดมาตรฐานใหม่โดยรับ IEC 61000-4-11 (2004-03) Electromagnetic Compatibility (EMC) Part 4-11: Testing and measurement techniques voltage dips, short interruptions and voltage variations immunity tests มาใช้ในระดับเหมือนกันทุกประการโดยใช้มาตรฐาน IEC ฉบับภาษาอังกฤษเป็นหลัก

คณะกรรมการมาตรฐานผลิตภัณฑ์อุตสาหกรรมได้พิจารณามาตรฐานนี้แล้ว เห็นสมควรเสนอรัฐมนตรีประกาศตาม มาตรา 15 แห่งพระราชบัญญัติมาตรฐานผลิตภัณฑ์อุตสาหกรรม พ.ศ. 2511



ประกาศกระทรวงอุตสาหกรรม

ฉบับที่ 4077 (พ.ศ. 2552)

ออกตามความในพระราชบัญญัติมาตรฐานผลิตภัณฑ์อุตสาหกรรม

พ.ศ. 2511

เรื่อง ยกเลิกและกำหนดมาตรฐานผลิตภัณฑ์อุตสาหกรรม

ความเข้ากันได้ทางแม่เหล็กไฟฟ้า

เล่ม 4 เทคนิคการทดสอบและการวัด

ส่วนที่ 11 การทดสอบภูมิคุ้มกันเมื่อแรงดันไฟฟ้าดิ่งลง

ขาดหายไปเป็นระยะเวลาสั้น ๆ และแปรเปลี่ยน

โดยที่เป็นการสมควรปรับปรุงมาตรฐานผลิตภัณฑ์อุตสาหกรรม ความเข้ากันได้ทางแม่เหล็กไฟฟ้า เล่ม 4 เทคนิคการทดสอบและการวัด ส่วนที่ 11 การทดสอบภูมิคุ้มกันเมื่อแรงดันไฟฟ้าดิ่งลง ขาดหายไปเป็นระยะเวลาสั้น ๆ และแปรเปลี่ยน มาตรฐานเลขที่ มอก.1460-2540

อาศัยอำนาจตามความในมาตรา 15 แห่งพระราชบัญญัติมาตรฐานผลิตภัณฑ์อุตสาหกรรม พ.ศ. 2511 รัฐมนตรีว่าการกระทรวงอุตสาหกรรมออกประกาศยกเลิกประกาศกระทรวงอุตสาหกรรม ฉบับที่ 2362 (พ.ศ.2541) ออกตามความในพระราชบัญญัติมาตรฐานผลิตภัณฑ์อุตสาหกรรม พ.ศ. 2511 เรื่อง กำหนดมาตรฐานผลิตภัณฑ์อุตสาหกรรม ความเข้ากันได้ทางแม่เหล็กไฟฟ้า เล่ม 4 เทคนิคการทดสอบและการวัด ส่วนที่ 11 การทดสอบภูมิคุ้มกันเมื่อแรงดันไฟฟ้าดิ่งลง ขาดหายไปเป็นระยะเวลาสั้น ๆ และแปรเปลี่ยน ลงวันที่ 9 กุมภาพันธ์ พ.ศ. 2541 และออกประกาศกำหนดมาตรฐานผลิตภัณฑ์อุตสาหกรรม ความเข้ากันได้ทางแม่เหล็กไฟฟ้า เล่ม 4 เทคนิคการทดสอบและการวัด ส่วนที่ 11 การทดสอบภูมิคุ้มกันเมื่อแรงดันไฟฟ้าดิ่งลง ขาดหายไปเป็นระยะเวลาสั้น ๆ และแปรเปลี่ยน มาตรฐานเลขที่ มอก.1460-2552 ขึ้นใหม่ ดังมีรายละเอียดต่อท้ายประกาศนี้

ทั้งนี้ให้มีผลตั้งแต่วันที่ถัดจากวันที่ประกาศในราชกิจจานุเบกษา เป็นต้นไป

ประกาศ ณ วันที่ 1 กันยายน พ.ศ. 2552

ชาญชัย ชัยรุ่งเรือง

รัฐมนตรีว่าการกระทรวงอุตสาหกรรม

มาตรฐานผลิตภัณฑ์อุตสาหกรรม ความเข้ากันได้ทางแม่เหล็กไฟฟ้า

เล่ม 4 เทคนิคการทดสอบและการวัด ส่วนที่ 11 การทดสอบภูมิคุ้มกันเมื่อแรงดันไฟฟ้าดิ่งลง ขาดหายไปเป็นระยะเวลาสั้น ๆ และแปรเปลี่ยน

มาตรฐานผลิตภัณฑ์อุตสาหกรรมนี้กำหนดขึ้นโดยรับ IEC 61000-4-11 (2004-03) Electromagnetic Compatibility (EMC) Part 4-11: Testing and measurement techniques voltage dips, short interruptions and voltage variations immunity tests มาใช้ในระดับเหมือนกันทุกประการ (Identical) โดยใช้ฉบับภาษาอังกฤษเป็นหลัก

มาตรฐานผลิตภัณฑ์อุตสาหกรรมนี้กำหนดวิธีการทดสอบภูมิคุ้มกัน และพิสัยของระดับการทดสอบที่นิยมสำหรับ บริษัทไฟฟ้าและอิเล็กทรอนิกส์ซึ่งต่อกับวงจรเครือข่ายแหล่งจ่ายกำลังไฟฟ้าแรงดันต่ำ เมื่อแรงดันไฟฟ้าดิ่งลง ขาดหายไปเป็นระยะเวลาสั้น ๆ และแปรเปลี่ยน

มาตรฐานนี้ใช้กับบริษัทไฟฟ้าและอิเล็กทรอนิกส์ที่มีกระแสไฟฟ้าเข้าที่กำหนดไม่เกิน 16 แอมแปร์ต่อเฟส เมื่อ เชื่อมต่อที่ความถี่ 50 หรือ 60 เฮิร์ตซ์ของเครือข่ายไฟฟ้ากระแสสลับ แต่ไม่ใช้กับบริษัทไฟฟ้าอิเล็กทรอนิกส์ที่ต่อกับ เครือข่ายไฟฟ้ากระแสสลับความถี่ 400 เฮิร์ตซ์ ซึ่งการทดสอบสำหรับเครือข่ายเหล่านี้จะครอบคลุมโดยมาตรฐาน IEC ที่จะประกาศต่อไปในอนาคต

วัตถุประสงค์ของมาตรฐานนี้เพื่อจัดตั้งพื้นฐานที่ใช้ร่วมกันสำหรับการประเมินด้านภูมิคุ้มกันของบริษัทไฟฟ้าและ อิเล็กทรอนิกส์ เมื่ออยู่ภายใต้อิทธิพลของแรงดันไฟฟ้าดิ่งลง ขาดหายไปเป็นระยะเวลาสั้น ๆ และแปรเปลี่ยน

หมายเหตุ การทดสอบภูมิคุ้มกันกับการแกว่งของแรงดันไฟฟ้า ครอบคลุมโดยมาตรฐาน IEC 61000-4-14

วิธีทดสอบที่ถูกระบุอยู่ในมาตรฐาน IEC 61000 ส่วนนี้ อธิบายวิธีที่สอดคล้องในการประเมินภูมิคุ้มกันของ บริษัท หรือระบบที่ด้านปรากฏการณ์ต่าง ๆ ตามที่นิยามไว้ และ โดยวิธีทดสอบนี้เป็นประกาศพื้นฐานของ EMC เพื่อใช้โดย คณะกรรมการผลิตภัณฑ์ของ IEC ตามที่อธิบายไว้ใน IEC Guide 107 ทั้งยังได้กล่าวไว้ใน Guide 107 อีกว่า คณะกรรมการผลิตภัณฑ์ IEC จะต้องรับผิดชอบในการพิจารณาว่ามาตรฐานการทดสอบภูมิคุ้มกันว่าควรนำมา ประยุกต์ ใช้หรือไม่ และหากมีการนำมาประยุกต์ใช้ คณะกรรมการผลิตภัณฑ์ IEC จะต้องรับผิดชอบในการกำหนดระดับ การทดสอบที่เหมาะสม คณะกรรมการทางเทคนิคที่ 77 และคณะอนุกรรมการที่เกี่ยวข้องต้องเตรียมพร้อมในการให้ ความร่วมมือกับคณะกรรมการ ผลิตภัณฑ์ในการประเมินค่าเฉพาะของการทดสอบภูมิคุ้มกันของผลิตภัณฑ์

รายละเอียดให้เป็นไปตาม IEC 61000-4-11 (2004)

© IEC 2004

เอกสารนี้เป็นสิทธิ์ของ IEC หากมิได้กำหนดไว้เป็นอย่างอื่นห้ามนำมาตรฐานฉบับนี้หรือ
ส่วนหนึ่งส่วนใดไปทำซ้ำหรือใช้ประโยชน์ในรูปแบบ หรือโดยวิธีใด ๆ ไม่ว่าจะในรูปแบบ
อิเล็กทรอนิกส์หรือทางกล รวมถึงการถ่ายสำเนา ถ่ายไมโครฟิล์ม โดยไม่ได้รับอนุญาตเป็น
ลายลักษณ์อักษรจาก IEC ตามที่อยู่ข้างล่างหรือจากสมาชิก IEC ในประเทศของผู้ร้องขอ

IEC Central office

3, rue de Varembe',

CH-1211 Geneva 20

Switzerland

E-mail : inmail@iec.ch

Web : www.iec.ch

CONTENTS

FOREWORD	5
INTRODUCTION	9
1 Scope	11
2 Normative references	11
3 Terms and definitions	11
4 General	15
5 Test levels	15
6 Test instrumentation	23
7 Test set-up	27
8 Test procedures	29
9 Evaluation of test results	33
10 Test report	35
Annex A (normative) Test circuit details	37
Annex B (informative) Electromagnetic environment classes	43
Annex C (informative) Test instrumentation	45
Bibliography	51
Figure 1 – Voltage dip - Examples	21
Figure 2 – Short interruption	21
Figure 3 – Voltage variation	23
Figure 4 – Phase-to-neutral and phase-to-phase testing on three-phase systems	33
Figure A.1 – Circuit for determining the inrush current drive capability of the short interruptions generator	39
Figure A.2 – Circuit for determining the peak inrush current requirement of an EUT	41
Figure C.1 – Schematics of test instrumentation for voltage dips, short interruptions and voltage variations	47
Figure C.2 – Schematic of test instrumentation for three-phase voltage dips, short interruptions and voltage variations using power amplifier	49
Table 1 – Preferred test level and durations for voltage dips	17
Table 2 – Preferred test level and durations for short interruptions	17
Table 3 – Timing of short-term supply voltage variations	19
Table 4 – Generator specifications	25

INTERNATIONAL ELECTROTECHNICAL COMMISSION

ELECTROMAGNETIC COMPATIBILITY (EMC) –

**Part 4-11: Testing and measurement techniques –
Voltage dips, short interruptions and
voltage variations immunity tests**

FOREWORD

- 1) The International Electrotechnical Commission (IEC) is a worldwide organization for standardization comprising all national electrotechnical committees (IEC National Committees). The object of IEC is to promote international co-operation on all questions concerning standardization in the electrical and electronic fields. To this end and in addition to other activities, IEC publishes International Standards, Technical Specifications, Technical Reports, Publicly Available Specifications (PAS) and Guides (hereafter referred to as “IEC Publication(s)”). Their preparation is entrusted to technical committees; any IEC National Committee interested in the subject dealt with may participate in this preparatory work. International, governmental and non-governmental organizations liaising with the IEC also participate in this preparation. IEC collaborates closely with the International Organization for Standardization (ISO) in accordance with conditions determined by agreement between the two organizations.
- 2) The formal decisions or agreements of IEC on technical matters express, as nearly as possible, an international consensus of opinion on the relevant subjects since each technical committee has representation from all interested IEC National Committees.
- 3) IEC Publications have the form of recommendations for international use and are accepted by IEC National Committees in that sense. While all reasonable efforts are made to ensure that the technical content of IEC Publications is accurate, IEC cannot be held responsible for the way in which they are used or for any misinterpretation by any end user.
- 4) In order to promote international uniformity, IEC National Committees undertake to apply IEC Publications transparently to the maximum extent possible in their national and regional publications. Any divergence between any IEC Publication and the corresponding national or regional publication shall be clearly indicated in the latter.
- 5) IEC provides no marking procedure to indicate its approval and cannot be rendered responsible for any equipment declared to be in conformity with an IEC Publication.
- 6) All users should ensure that they have the latest edition of this publication.
- 7) No liability shall attach to IEC or its directors, employees, servants or agents including individual experts and members of its technical committees and IEC National Committees for any personal injury, property damage or other damage of any nature whatsoever, whether direct or indirect, or for costs (including legal fees) and expenses arising out of the publication, use of, or reliance upon, this IEC Publication or any other IEC Publications.
- 8) Attention is drawn to the Normative references cited in this publication. Use of the referenced publications is indispensable for the correct application of this publication.
- 9) Attention is drawn to the possibility that some of the elements of this IEC Publication may be the subject of patent rights. IEC shall not be held responsible for identifying any or all such patent rights.

International Standard IEC 61000-4-11 has been prepared by subcommittee 77A: Low frequency phenomena, of IEC technical committee 77: Electromagnetic compatibility.

This second edition cancels and replaces the first edition published in 1994 and its amendment 1 (2000). This second edition constitutes a technical revision in which

- 1) preferred test values and durations have been added for the different environment classes;
- 2) the tests for the three-phase systems have been specified.

It forms part 4-11 of IEC 61000. It has the status of a Basic EMC Publication in accordance with IEC Guide 107.

The text of this standard is based on the following documents:

FDIS	Report on voting
77A/452/FDIS	77A/455/RVD

Full information on the voting for the approval of this standard can be found in the report on voting indicated in the above table.

This publication has been drafted in accordance with the ISO/IEC Directives, Part 2.

The committee has decided that the contents of this publication will remain unchanged until 2008. At this date, the publication will be

- reconfirmed;
- withdrawn;
- replaced by a revised edition, or
- amended.

INTRODUCTION

IEC 61000 is published in separate parts according to the following structure:

Part 1: General

General considerations (introduction, fundamental principles)
Definitions, terminology

Part 2: Environment

Description of the environment
Classification of the environment
Compatibility levels

Part 3: Limits

Emission limits
Immunity limits (in so far as they do not fall under the responsibility of the product committees)

Part 4: Testing and measurement techniques

Measurement techniques
Testing techniques

Part 5: Installation and mitigation guidelines

Installation guidelines
Mitigation methods and devices

Part 6: Generic standards

Part 9: Miscellaneous

Each part is further subdivided into several parts, published either as International Standards or as technical specifications or technical reports, some of which have already been published as sections. Others will be published with the part number followed by a dash and a second number identifying the subdivision (example: 61000-6-1).

ELECTROMAGNETIC COMPATIBILITY (EMC) –

Part 4-11: Testing and measurement techniques – Voltage dips, short interruptions and voltage variations immunity tests

1 Scope

This part of IEC 61000 defines the immunity test methods and range of preferred test levels for electrical and electronic equipment connected to low-voltage power supply networks for voltage dips, short interruptions, and voltage variations.

This standard applies to electrical and electronic equipment having a rated input current not exceeding 16 A per phase, for connection to 50 Hz or 60 Hz a.c. networks.

It does not apply to electrical and electronic equipment for connection to 400 Hz a.c. networks. Tests for these networks will be covered by future IEC standards.

The object of this standard is to establish a common reference for evaluating the immunity of electrical and electronic equipment when subjected to voltage dips, short interruptions and voltage variations.

NOTE Voltage fluctuation immunity tests are covered by IEC 61000-4-14.

The test method documented in this part of IEC 61000 describes a consistent method to assess the immunity of equipment or a system against a defined phenomenon. As described in IEC Guide 107, this is a basic EMC publication for use by product committees of the IEC. As also stated in Guide 107, the IEC product committees are responsible for determining whether this immunity test standard should be applied or not, and, if applied, they are responsible for defining the appropriate test levels. Technical committee 77 and its sub-committees are prepared to co-operate with product committees in the evaluation of the value of particular immunity tests for their products.

2 Normative references

The following referenced documents are indispensable for the application of this document. For dated references, only the edition cited applies. For undated references, the latest edition of the referenced document (including any amendments) applies.

IEC 61000-2-8, *Electromagnetic compatibility (EMC) – Part 2-8: Environment – Voltage dips and short interruptions on public electric power supply systems with statistical measurement results*

3 Terms and definitions

For the purpose of this document, the following terms and definitions apply:

3.1

basic EMC standard

standard giving general and fundamental conditions or rules for the achievement of EMC, which are related or applicable to all products and systems and serve as reference documents for product committees

NOTE As determined by the Advisory Committee on Electromagnetic Compatibility (ACEC) – see IEC Guide 107.

3.2

immunity (to a disturbance)

the ability of a device, equipment or system to perform without degradation in the presence of an electromagnetic disturbance

[IEV 161-01-20]

3.3

voltage dip

a sudden reduction of the voltage at a particular point of an electricity supply system below a specified dip threshold followed by its recovery after a brief interval

NOTE 1 Typically, a dip is associated with the occurrence and termination of a short circuit or other extreme current increase on the system or installations connected to it.

NOTE 2 A voltage dip is a two-dimensional electromagnetic disturbance, the level of which is determined by both voltage and time (duration).

3.4

short interruption

a sudden reduction of the voltage on all phases at a particular point of an electric supply system below a specified interruption threshold followed by its restoration after a brief interval

NOTE Short interruptions are typically associated with switchgear operations related to the occurrence and termination of short circuits on the system or on installations connected to it.

3.5

residual voltage (of voltage dip)

the minimum value of r.m.s. voltage recorded during a voltage dip or short interruption

NOTE The residual voltage may be expressed as a value in volts or as a percentage or per unit value relative to the reference voltage.

3.6

malfunction

the termination of the ability of equipment to carry out intended functions or the execution of unintended functions by the equipment

3.7

calibration

method to prove that the measurement equipment is in compliance with its specifications

NOTE For the purposes of this standard, calibration is applied to the test generator.

3.8

verification

set of operations which is used to check the test equipment system (e.g. the test generator and the interconnecting cables) to demonstrate that the test system is functioning within the specifications given in Clause 6

NOTE 1 The methods used for verification may be different from those used for calibration.

NOTE 2 The verification procedure of 6.1.2 is meant as a guide to insure the correct operation of the test generator, and other items making up the test set-up that the intended waveform is delivered to the EUT.

4 General

Electrical and electronic equipment may be affected by voltage dips, short interruptions or voltage variations of power supply.

Voltage dips and short interruptions are caused by faults in the network, primarily short circuits (see also IEC 61000-2-8), in installations or by sudden large changes of load. In certain cases, two or more consecutive dips or interruptions may occur. Voltage variations are caused by continuously varying loads connected to the network.

These phenomena are random in nature and can be minimally characterized for the purpose of laboratory simulation in terms of the deviation from the rated voltage and duration.

Consequently, different types of tests are specified in this standard to simulate the effects of abrupt voltage change. These tests are to be used only for particular and justified cases, under the responsibility of product specification or product committees.

It is the responsibility of the product committees to establish which phenomena among the ones considered in this standard are relevant and to decide on the applicability of the test.

5 Test levels

The voltages in this standard use the rated voltage for the equipment (U_T) as a basis for voltage test level specification.

Where the equipment has a rated voltage range the following shall apply:

- if the voltage range does not exceed 20 % of the lower voltage specified for the rated voltage range, a single voltage within that range may be specified as a basis for test level specification (U_T);
- in all other cases, the test procedure shall be applied for both the lowest and highest voltages declared in the voltage range;
- guidance for the selection of test levels and durations is given in IEC 61000-2-8.

5.1 Voltage dips and short interruptions

The change between U_T and the changed voltage is abrupt. The step can start and stop at any phase angle on the mains voltage. The following test voltage levels (in % U_T) are used: 0 %, 40 %, 70 % and 80 %, corresponding to dips with residual voltages of 0 %, 40 %, 70 % and 80 %.

For voltage dips, the preferred test levels and durations are given in Table 1, and an example is shown in Figure 1a) and Figure 1b).

For short interruptions, the preferred test levels and durations are given in Table 2, and an example is shown in Figure 2.

The preferred test levels and durations given in Tables 1 and 2 take into account the information given in IEC 61000-2-8.

The preferred test levels in Table 1 are reasonably severe, and are representative of many real world dips, but are not intended to guarantee immunity to all voltage dips. More severe dips, for example 0 % for 1 s and balanced three-phase dips, may be considered by product committees.

The voltage rise time, t_r , and voltage fall time, t_f , during abrupt changes are indicated in Table 4.

The levels and durations shall be given in the product specification. A test level of 0 % corresponds to a total supply voltage interruption. In practice, a test voltage level from 0 % to 20 % of the rated voltage may be considered as a total interruption.

Shorter durations in the table, in particular the half-cycle, should be tested to be sure that the equipment under test (EUT) operates within the performance limits specified for it.

When setting performance criteria for disturbances of 0,5 period duration for products with a mains transformer, product committees should pay particular attention to effects which may result from inrush currents. For such products, these may reach 10 to 40 times the rated current because of magnetic flux saturation of the transformer core after the voltage dip.

Table 1 – Preferred test level and durations for voltage dips

Class ^a	Test level and durations for voltage dips (t_s) (50 Hz/60 Hz)				
Class 1	Case-by-case according to the equipment requirements				
Class 2	0 % during ½ cycle	0 % during 1 cycle	70 % during 25/30 ^c cycles		
Class 3	0 % during ½ cycle	0 % during 1 cycle	40 % during 10/12 ^c cycles	70 % during 25/30 ^c cycles	80 % during 250/300 ^c cycles
Class X ^b	X	X	X	X	X
^a Classes as per IEC 61000-2-4; see Annex B. ^b To be defined by product committee. For equipment connected directly or indirectly to the public network, the levels must not be less severe than Class 2. ^c "25/30 cycles" means "25 cycles for 50 Hz test" and "30 cycles for 60 Hz test".					

Table 2 – Preferred test level and durations for short interruptions

Class ^a	Test level and durations for short interruptions (t_s) (50 Hz/60 Hz)
Class 1	Case-by-case according to the equipment requirements
Class 2	0 % during 250/300 ^c cycles
Class 3	0 % during 250/300 ^c cycles
Class X ^b	X
^a Classes as per IEC 61000-2-4; see Annex B. ^b To be defined by product committee. For equipment connected directly or indirectly to the public network, the levels must not be less severe than Class 2. ^c "250/300 cycles" means "250 cycles for 50 Hz test" and "300 cycles for 60 Hz test".	

5.2 Voltage variations (optional)

This test considers a defined transition between rated voltage U_T and the changed voltage.

NOTE The voltage change takes place over a short period, and may occur due to change of load.

The preferred duration of the voltage changes and the time for which the reduced voltages are to be maintained are given in Table 3. The rate of change should be constant; however, the voltage may be stepped. The steps should be positioned at zero crossings, and should be no larger than 10 % of U_T . Steps under 1 % of U_T are considered as constant rates of change of voltage.

Table 3 – Timing of short-term supply voltage variations

Voltage test level	Time for decreasing voltage (t_d)	Time at reduced voltage (t_s)	Time for increasing voltage (t_i) (50 Hz/60 Hz)
70 %	Abrupt	1 cycle	25/30 ^b cycles
X ^a	X ^a	X ^a	X ^a

^a To be defined by product committee.
^b "25/30 cycles" means "25 cycles for 50 Hz test" and "30 cycles for 60 Hz test".

This shape is the typical shape of a motor starting.

Figure 3 shows the r.m.s. voltage as a function of time. Other values may be taken in justified cases and shall be specified by the product committee.

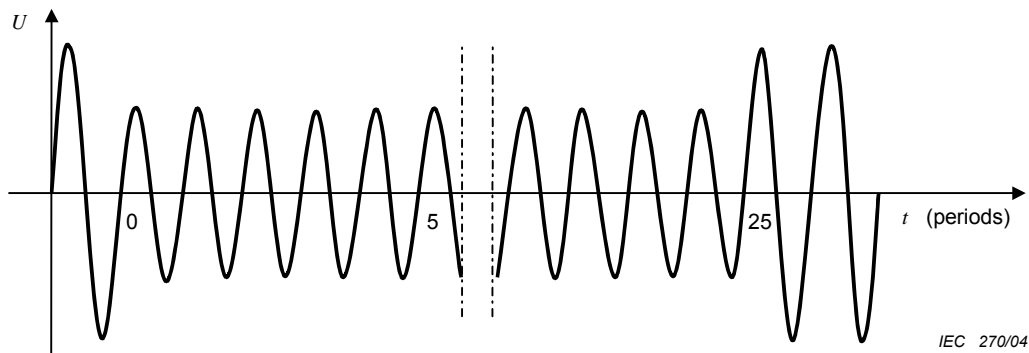

NOTE The voltage decreases to 70 % for 25 periods. Step at zero crossing.

Figure 1a) – Voltage dip – 70 % voltage dip sine wave graph

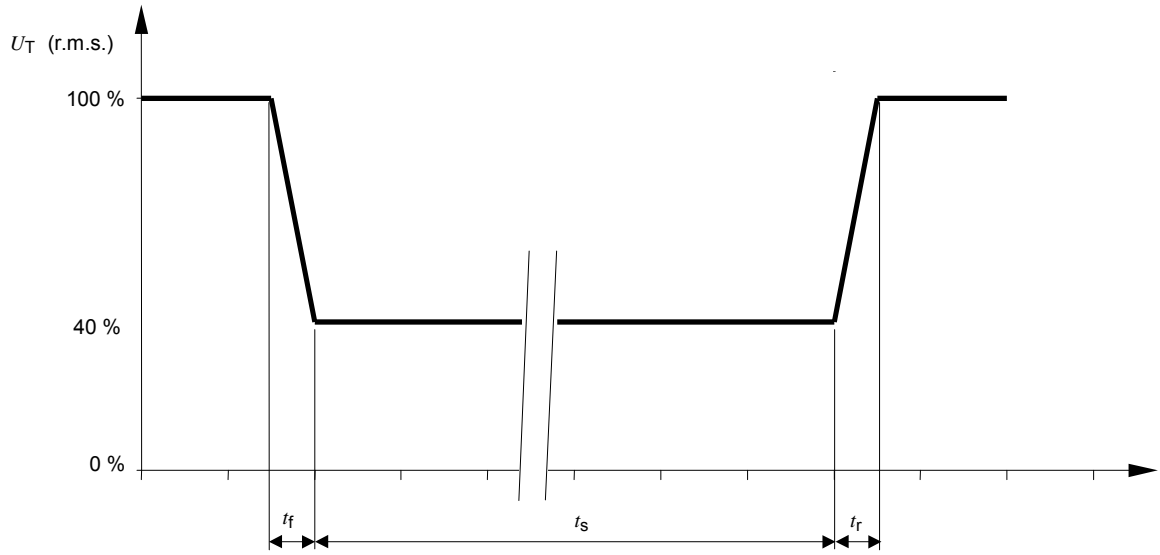

IEC 271/04

Key

- t_r Voltage rising time
- t_f Voltage fall time
- t_s Time at reduced voltage

Figure 1b) – Voltage dip – 40 % voltage dip r.m.s. graph

Figure 1 – Voltage dip - Examples

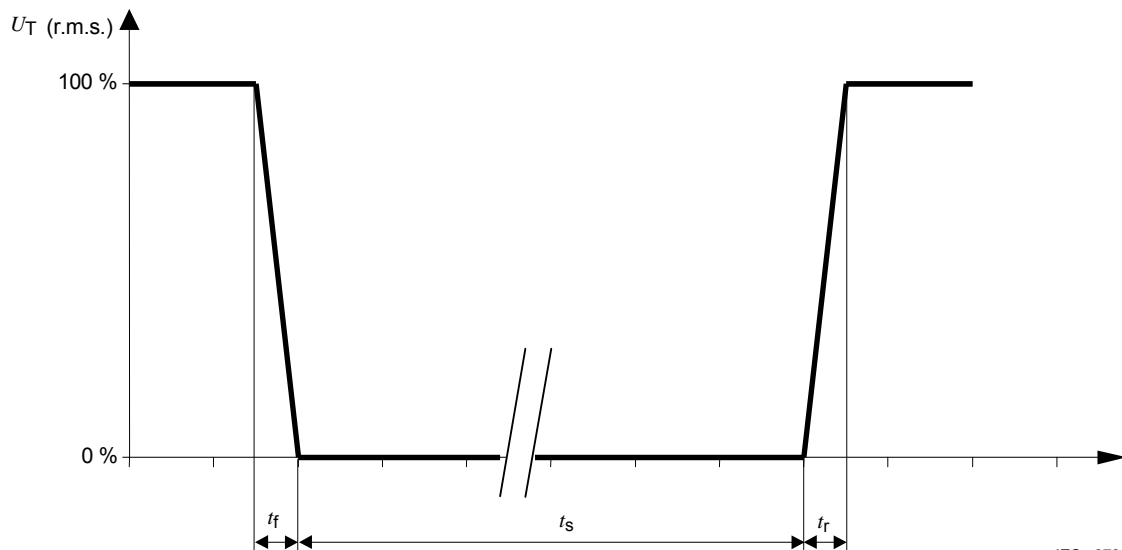

IEC 272/04

Key

- t_r Voltage rising time
- t_f Voltage fall time
- t_s Time at reduced voltage

Figure 2 – Short interruption

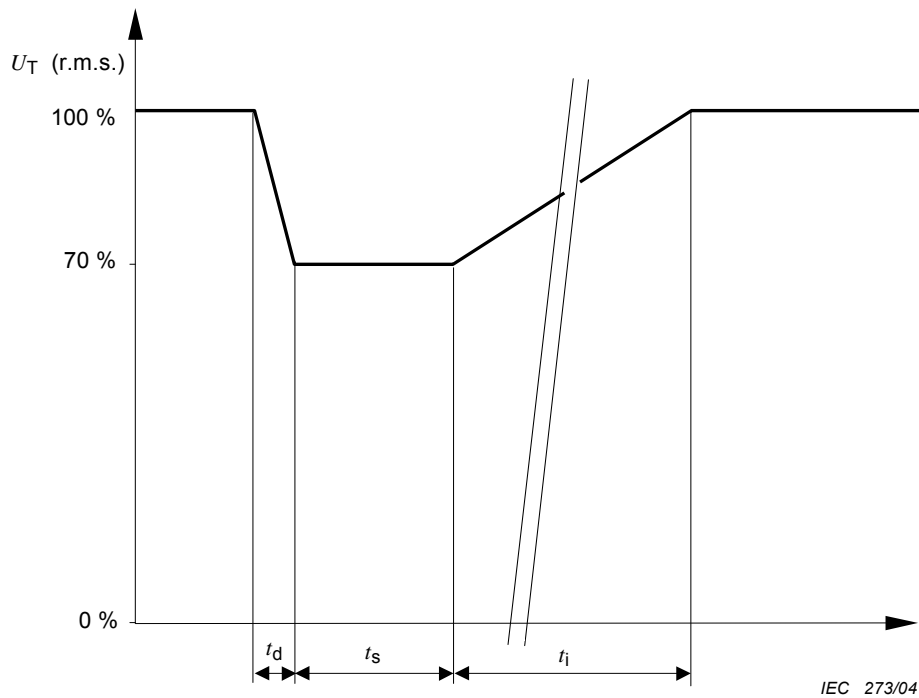

Key

- t_d Time for decreasing voltage
- t_i Time for increasing voltage
- t_s Time at reduced voltage

Figure 3 – Voltage variation

6 Test instrumentation

6.1 Test generator

The following features are common to the generator for voltage dips, short interruptions and voltage variations, except as indicated.

Examples of generators are given in Annex C.

The generator shall have provision to prevent the emission of heavy disturbances, which, if injected in the power supply network, may influence the test results.

Any generator creating a voltage dip of equal or more severe characteristics (amplitude and duration) than that prescribed by the present standard is permitted.

6.1.1 Characteristics and performance of the generator

Table 4 – Generator specifications

Output voltage at no load	As required in Table 1, $\pm 5\%$ of residual voltage value
Voltage change with load at the output of the generator	
100 % output, 0 A to 16 A	less than 5 % of U_T
80 % output 0 A to 20 A	less than 5 % of U_T
70 % output, 0 A to 23 A	less than 5 % of U_T
40 % output, 0 A to 40 A	less than 5 % of U_T
Output current capability	16 A r.m.s. per phase at rated voltage. The generator shall be capable of carrying 20 A at 80 % of rated value for a duration of 5 s. It shall be capable of carrying 23 A at 70 % of rated voltage and 40 A at 40 % of rated voltage for a duration of 3 s. (This requirement may be reduced according to the EUT rated steady-state supply current, see Clause A.3).
Peak inrush current capability (no requirement for voltage variation tests)	Not to be limited by the generator. However, the maximum peak capability of the generator need not exceed 1 000 A for 250 V to 600 V mains, 500 A for 200 V to 240 V mains, or 250 A for 100 V to 120 V mains.
Instantaneous peak overshoot/undershoot of the actual voltage, generator loaded with 100 Ω resistive load	Less than 5 % of U_T
Voltage rise (and fall) time t_r (and t_f), see Figures 1b) and 2, during abrupt change, generator loaded with 100 Ω resistive load	Between 1 μ s and 5 μ s
Phase shifting (if necessary)	0° to 360°
Phase relationship of voltage dips and interruptions with the power frequency	Less than $\pm 10^\circ$
Zero crossing control of the generators	$\pm 10^\circ$

Output impedance shall be predominantly resistive.

The output impedance of the test voltage generator shall be low even during transitions (for example, less than $0,4 + j0,25 \Omega$).

NOTE 1 The 100 Ω resistive load used to test the generator should not have additional inductivity.

NOTE 2 To test equipment which regenerates energy, an external resistor connected in parallel to the load can be added. The test result must not be influenced by this load.

6.1.2 Verification of the characteristics of the voltage dips, short interruptions generators

In order to compare the test results obtained from different test generators, the generator characteristics shall be verified according to the following:

- the 100 %, 80 %, 70 % and 40 % r.m.s. output voltages of the generator shall conform to those percentages of the selected operating voltage: 230 V, 120 V, etc.;
- the 100 %, 80 %, 70 % and 40 % r.m.s. output voltages of the generator shall be measured at no load, and shall be maintained within a specified percentage of the U_T ;

- load regulation shall be verified at nominal load current at each of the output voltages and the variation shall not exceed 5 % of the nominal power supply voltage at 100 %, 80 %, 70 % and 40 % of the nominal power supply voltage.

For output voltage of 80 % of the nominal value, the above requirements need only be verified for a maximum of 5 s duration.

For output voltages of 70 % and 40 % of the nominal value, the above requirements need only be verified for a maximum of 3 s duration.

If it is necessary to verify the peak inrush drive current capability, the generator shall be switched from 0 % to 100 % of full output, when driving a load consisting of a suitable rectifier with an uncharged capacitor whose value is 1 700 μ F on the d.c. side. The test shall be carried out at phase angles of both 90° and 270°. The circuit required to measure generator inrush current drive capability is given in Figure A.1.

When it is believed that a generator with less than the specified standard generator peak inrush current may be used because the EUT may draw less than the specified standard generator peak inrush current (e.g., 500 A for 220 V-240 V mains), this shall first be confirmed by measuring the EUT peak inrush current. When power is applied from the test generator, measured EUT peak inrush current shall be less than 70 % of the peak current drive capability of the generator, as already verified according to Annex A. The actual EUT inrush current shall be measured both from a cold start and after a 5 s turn-off, using the procedure of Clause A.3.

Generator switching characteristics shall be measured with a 100 Ω load of suitable power-dissipation rating.

NOTE The 100 Ω resistive load used to test the generator should not have additional inductivity.

Rise and fall time, as well as overshoot and undershoot, shall be verified for switching at both 90° and 270°, from 0 % to 100 %, 100 % to 80 %, 100 % to 70 %, 100 % to 40 %, and 100 % to 0 %.

Phase angle accuracy shall be verified for switching from 0 % to 100 % and 100 % to 0 %, at nine phase angles from 0° to 360° in 45° increments. It shall also be verified for switching from 100 % to 80 % and 80 % to 100 %, 100 % to 70 % and 70 % to 100 %, as well as from 100 % to 40 % and 40 % to 100 %, at 90° and 180°.

The voltage generators shall, preferably, be recalibrated at defined time periods in accordance with a recognized quality assurance system.

6.2 Power source

The frequency of the test voltage shall be within $\pm 2\%$ of rated frequency.

7 Test set-up

The test shall be performed with the EUT connected to the test generator with the shortest power supply cable as specified by the EUT manufacturer. If no cable length is specified, it shall be the shortest possible length suitable to the application of the EUT.

The test set-ups for the three types of phenomena described in this standard are:

- voltage dips;
- short interruptions;
- voltage variations with gradual transition between the rated voltage and the changed voltage (option).

Examples of test set-ups are given in Annex C.

Figure C.1a) shows a schematic for the generation of voltage dips, short interruptions and voltage variations with gradual transition between rated and changed voltage using a generator with internal switching, and Figure C.1b) using a generator and a power amplifier.

Figure C.2 shows a schematic for the generation of voltage dips, short interruptions and voltage variations using a generator and a power amplifier for three-phase equipment.

8 Test procedures

Before starting the test of a given EUT, a test plan shall be prepared.

The test plan should be representative of the way the system is actually used.

Systems may require a precise pre-analysis to define which system configurations must be tested to reproduce field situations.

Test cases must be explained and indicated in the Test report.

It is recommended that the test plan include the following items:

- the type designation of the EUT;
- information on possible connections (plugs, terminals, etc.) and corresponding cables, and peripherals;
- input power port of equipment to be tested;
- representative operational modes of the EUT for the test;
- performance criteria used and defined in the technical specifications;
- operational mode(s) of equipment;
- description of the test set-up.

If the actual operating signal sources are not available to the EUT, they may be simulated.

For each test, any degradation of performance shall be recorded. The monitoring equipment should be capable of displaying the status of the operational mode of the EUT during and after the tests. After each group of tests, a full functional check shall be performed.

8.1 Laboratory reference conditions

8.1.1 Climatic conditions

Unless otherwise specified by the committee responsible for the generic or product standard, the climatic conditions in the laboratory shall be within any limits specified for the operation of the EUT and the test equipment by their respective manufacturers.

Tests shall not be performed if the relative humidity is so high as to cause condensation on the EUT or the test equipment.

NOTE Where it is considered that there is sufficient evidence to demonstrate that the effects of the phenomenon covered by this standard are influenced by climatic conditions, this should be brought to the attention of the committee responsible for this standard.

8.1.2 Electromagnetic conditions

The electromagnetic conditions of the laboratory shall be such as to guarantee the correct operation of the EUT in order not to influence the test results.

8.2 Execution of the test

During the tests, the mains voltage for testing shall be monitored within an accuracy of 2 %.

8.2.1 Voltage dips and short interruptions

The EUT shall be tested for each selected combination of test level and duration with a sequence of three dips/interruptions with intervals of 10 s minimum (between each test event). Each representative mode of operation shall be tested.

For voltage dips, changes in supply voltage shall occur at zero crossings of the voltage, and at additional angles considered critical by product committees or individual product specifications preferably selected from 45°, 90°, 135°, 180°, 225°, 270° and 315° on each phase.

For short interruptions, the angle shall be defined by the product committee as the worst case. In the absence of definition, it is recommended to use 0° for one of the phases.

For the short interruption test of three-phase systems, all the three phases shall be simultaneously tested as per 5.1.

For the voltage dips test of single-phase systems, the voltage shall be tested as per 5.1. This implies one series of tests.

For the voltage dips test of three-phase systems with neutral, each individual voltage (phase-to-neutral and phase-to-phase) shall be tested, one at a time, as per 5.1. This implies six different series of tests. See Figure 4b).

For the voltage dips test of three-phase systems without neutral, each phase-to-phase voltage shall be tested, one at a time, as per 5.1. This implies three different series of tests. See Figure 4b).

NOTE For three-phase systems, during a dip on a phase-to-phase voltage a change will occur on one or two of the other voltages as well.

For EUTs with more than one power cord, each power cord should be tested individually.

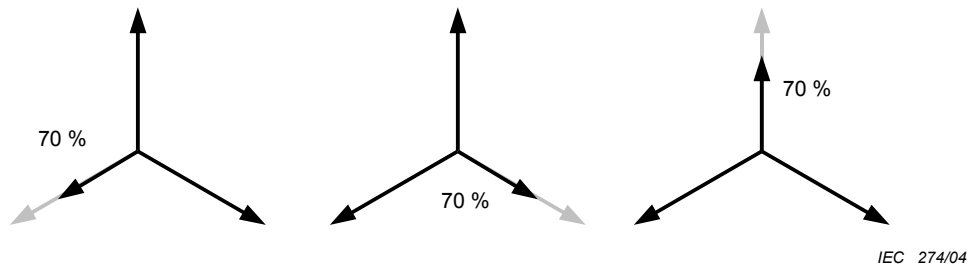

NOTE Phase-to-neutral testing on three-phase systems is performed one phase at a time.

Figure 4a) – Phase-to-neutral testing on three-phase systems

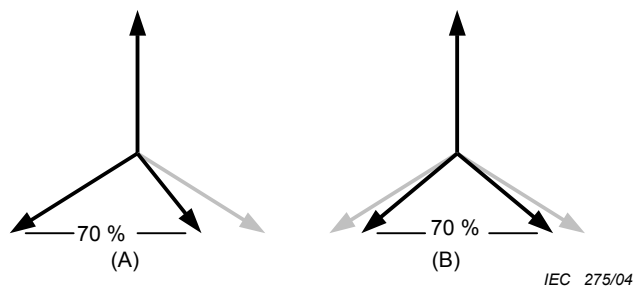

NOTE Phase-to-phase testing on three-phase phase systems is also performed one phase at a time. Both (A) and (B) show a 70 % dip. (A) is preferred, but (B) is also acceptable.

Figure 4b) – Phase-to-phase testing on three-phase systems

Figure 4 – Phase-to-neutral and phase-to-phase testing on three-phase systems

8.2.2 Voltage variations (optional)

The EUT is tested to each of the specified voltage variations, three times at 10 s interval for the most representative modes of operations.

9 Evaluation of test results

The test results shall be classified in terms of the loss of function or degradation of performance of the equipment under test, relative to a performance level defined by its manufacturer or the requestor of the test, or agreed between the manufacturer and the purchaser of the product. The recommended classification is as follows:

- normal performance within limits specified by the manufacturer, requestor or purchaser;
- temporary loss of function or degradation of performance which ceases after the disturbance ceases, and from which the equipment under test recovers its normal performance, without operator intervention;
- temporary loss of function or degradation of performance, the correction of which requires operator intervention;
- loss of function or degradation of performance which is not recoverable, owing to damage to hardware or software, or loss of data.

The manufacturer's specification may define effects on the EUT which may be considered insignificant, and therefore acceptable.

This classification may be used as a guide in formulating performance criteria, by committees responsible for generic, product and product-family standards, or as a framework for the agreement on performance criteria between the manufacturer and the purchaser, for example where no suitable generic, product or product-family standard exists.

NOTE The performance levels may be different for voltage dip tests and short interruption tests as well as for voltage variations tests, if this optional test has been required.

10 Test report

The test report shall contain all the information necessary to reproduce the test. In particular, the following shall be recorded:

- the items specified in the test plan required by Clause 8;
- identification of the EUT and any associated equipment, e.g. brand name, product type, serial number;
- identification of the test equipment, e.g. brand name, product type, serial number;
- any special environmental conditions in which the test was performed, for example shielded enclosure;
- any specific conditions necessary to enable the test to be performed;
- performance level defined by the manufacturer, requestor or purchaser;
- performance criterion specified in the generic, product or product-family standard;
- any effects on the EUT observed during or after the application of the test disturbance, and the duration for which these effects persist;
- the rationale for the pass / fail decision (based on the performance criterion specified in the generic, product or product-family standard, or agreed between the manufacturer and the purchaser);
- any specific conditions of use, for example cable length or type, shielding or grounding, or EUT operating conditions, which are required to achieve compliance.

Annex A (normative)

Test circuit details

A.1 Test generator peak inrush current drive capability

The circuit for measuring generator peak inrush current drive capability is shown in Figure A.1. Use of the bridge rectifier makes it unnecessary to change rectifier polarity for tests at 270° versus 90°. The rectifier half-cycle mains current rating should be at least twice the generator's inrush current drive capability to provide a suitable operating safety factor.

The 1 700 µF electrolytic capacitor shall have a tolerance of ±20 %. It shall have a voltage rating preferably 15 % – 20 % in excess of the nominal peak voltage of the mains, for example 400 V for 220 V – 240 V mains. It shall also be able to accommodate peak inrush current up to at least twice the generator's inrush current drive capability, to provide an adequate operating safety factor. The capacitor shall have the lowest possible equivalent series resistance (ESR) at both 100 Hz and 20 kHz, not exceeding 0,1 Ω at either frequency.

Since the test shall be performed with the 1 700 µF capacitor discharged, a resistor shall be connected in parallel with it and several time constants (RC) must be allowed between tests. With a 10 000 Ω resistor, the RC time constant is 17 s, so that a wait of 1,5 min to 2 min should be used between inrush drive capability tests. Resistors as low as 100 Ω may be used when shorter wait times are desired.

The current probe shall be able to accommodate the full generator peak inrush current drive for one-quarter cycle without saturation.

Tests shall be run by switching the generator output from 0 % to 100 % at both 90° and 270°, to ensure sufficient peak inrush current drive capability for both polarities.

A.2 Current monitor's characteristics for measuring peak inrush current capability

Output voltage in 50 Ω load:	0,01 V/A or more
Peak current:	1 000 A minimum
Peak current accuracy:	± 10 % (3 ms duration pulse)
r.m.s. current:	50 A minimum
$I \times T$ maximum:	10 A · s or more
Rise/fall time:	500 ns or less
Low-frequency 3 dB point:	10 Hz or less
Insertion resistor:	0,001 Ω or less

A.3 EUT peak inrush current requirement

When a generator peak inrush current drive capability meets the specified requirement (e.g., at least 500 A for a 220 V – 240 V mains), it is not necessary to measure the EUT peak inrush current requirement.

However, a generator with less than this inrush current may be used for the test, if the inrush requirement of the EUT is less than the inrush drive capability of the generator. The circuit of Figure A.2 shows an example of how to measure the peak inrush current of an EUT to determine if it is less than the inrush drive capability of a low-inrush drive capability generator.

The circuit uses the same current transformer as the circuit of Figure A.1. Four peak inrush current tests are performed:

- a) power off for at least 5 min; measure peak inrush current when it is turned back on at 90°;
- b) repeat a) at 270°;
- c) power on preferably for at least 1 min; off for 5 s; then measure peak inrush current when it is turned back on again at 90°;
- d) repeat c) at 270°.

In order to be able to use a low-inrush drive current capability generator to test a particular EUT, that EUT's measured inrush current shall be less than 70 % of the measured inrush current drive capability of the generator.

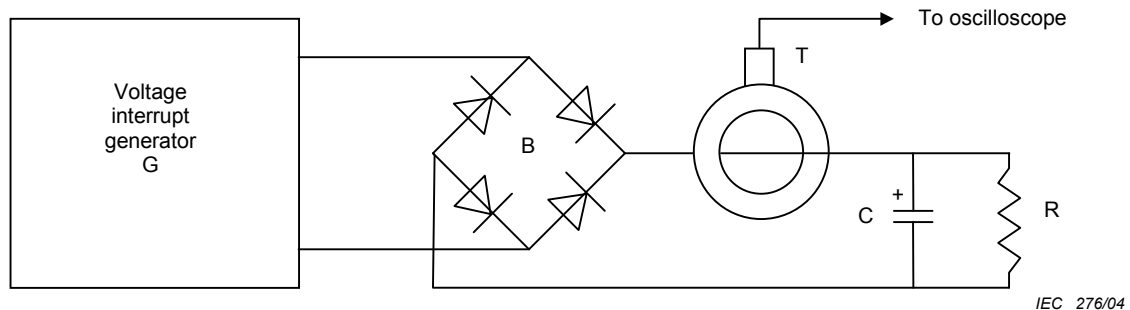

Components

- G voltage interrupt generator, switched on at 90° and 270°
- T current probe, with monitoring output to oscilloscope
- B rectifier bridge
- R bleeder resistor, not over 10 000 Ω or less than 100 Ω
- C 1 700 μF ± 20 % electrolytic capacitor

Figure A.1 – Circuit for determining the inrush current drive capability of the short interruptions generator

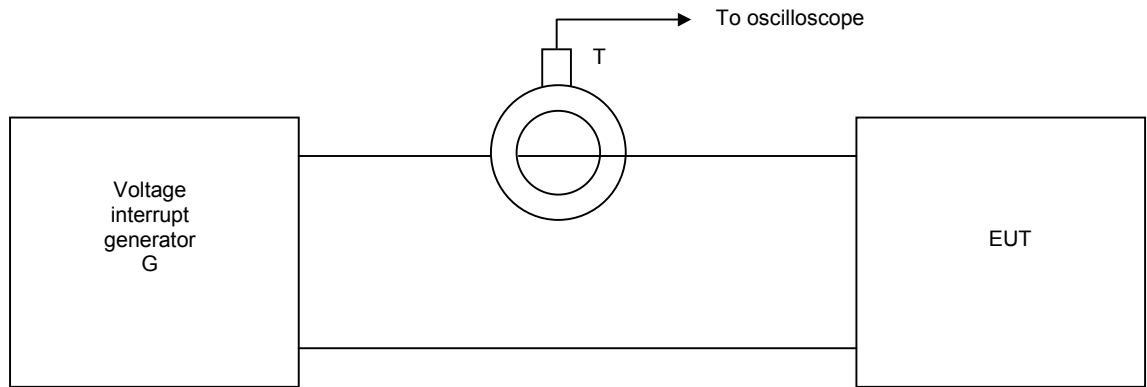

IEC 277/04

Figure A.2 – Circuit for determining the peak inrush current requirement of an EUT

Annex B (informative)

Electromagnetic environment classes

B.1 Electromagnetic environment classes

The following classes of electromagnetic environment classes have been summarised from IEC 61000-2-4.

- **Class 1**

This class applies to protected supplies and has compatibility levels lower than public network levels. It relates to the use of equipment very sensitive to disturbances in the power supply, for instance the instrumentation of technological laboratories, some automation and protection equipment, some computers, etc.

NOTE Class 1 environments normally contain equipment which requires protection by such apparatus as uninterruptible power supplies (UPS), filters, or surge suppressers.

- **Class 2**

This class applies to points of common coupling (PCC's for consumer systems) and in-plant points of common coupling (IPC's) in the industrial environment in general. The compatibility levels in this class are identical to those of public networks; therefore components designed for application in public networks may be used in this class of industrial environment.

- **Class 3**

This class applies only to IPC's in industrial environments. It has higher compatibility levels than those of class 2 for some disturbance phenomena. For instance, this class should be considered when any of the following conditions are met:

- a major part of the load is fed through converters;
- welding machines are present;
- large motors are frequently started;
- loads vary rapidly.

NOTE 1 The supply to highly disturbing loads, such as arc-furnaces and large converters which are generally supplied from a segregated bus-bar, frequently has disturbance levels in excess of class 3 (harsh environment). In such special situations, the compatibility levels should be agreed upon.

NOTE 2 The class applicable for new plants and extensions of existing plants should relate to the type of equipment and process under consideration.

Annex C (informative)

Test instrumentation

C.1 Examples of generators and test set-ups

Figures C.1a) and C.1b) show two possible test configurations for mains supply simulation. To show the behaviour of the EUT under certain conditions, interruptions and voltage variations are simulated by means of two transformers with variable output voltages.

Voltage drops, rises and interruptions are simulated by alternately closing switch 1 and switch 2. These two switches are never closed at the same time and an interval up to 100 μ s with the two switches opened is acceptable. It shall be possible to open and close the switches independently of the phase angle. Semiconductors switches constructed with power MOSFETs and IGBTs can fulfil this requirement. Thyristors and triacs open during current zero crossing, and therefore do not meet this requirement.

The output voltage of the variable transformers can either be adjusted manually or automatically by means of a motor. Alternatively, an autotransformer with multiple switch-selected taps may be used.

Wave-form generators and power amplifiers can be used instead of variable transformers and switches (see Figure C.1b)). This configuration also allows testing of the EUT in the context of frequency variations and harmonics.

The generators described for single-phase testing (see Figures C.1a), C.1b) and C.1c) can be also used for three-phase testing (see Figure C.2).

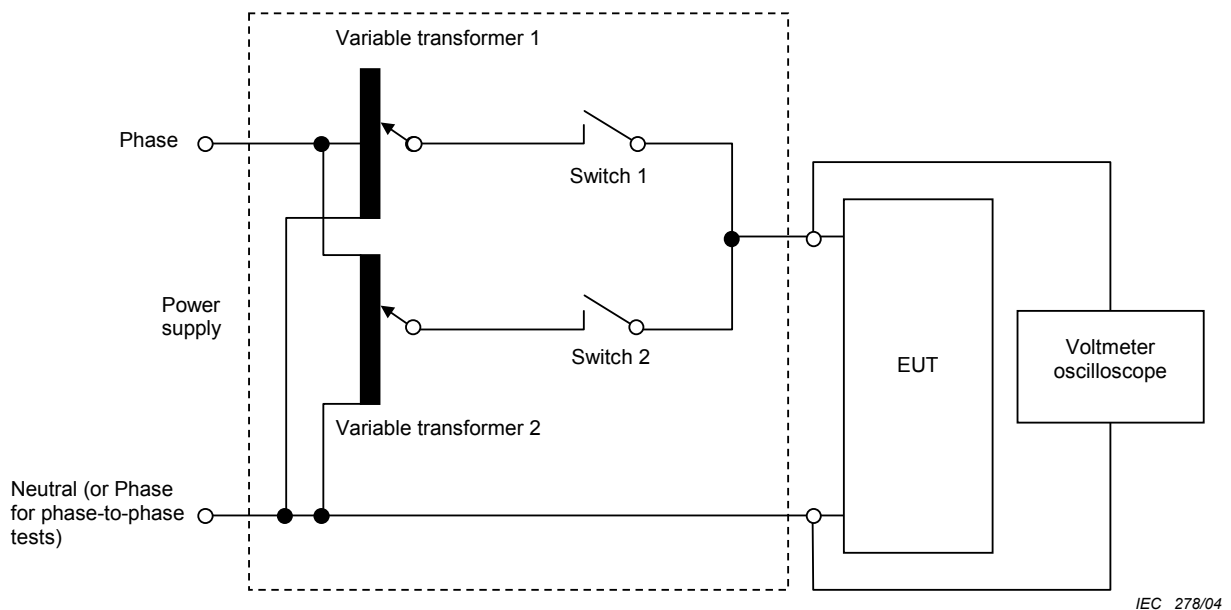

Figure C.1a) – Schematic of test instrumentation for voltage dips, short interruptions and voltage variations using variable transformers and switches

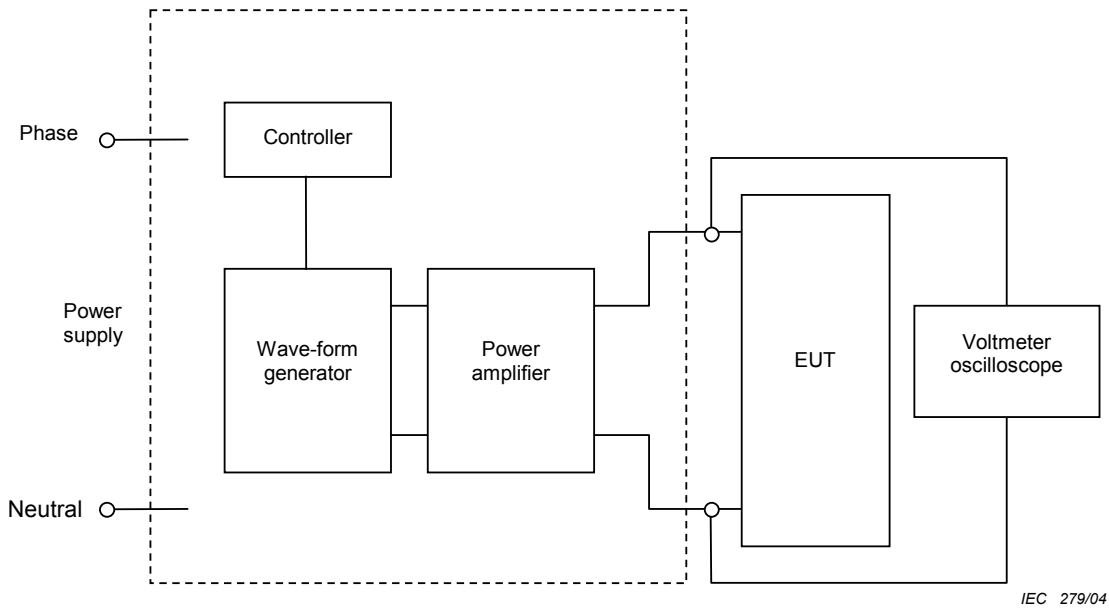

Figure C.1b) – Schematic of test instrumentation for voltage dips, short interruptions and voltage variations using power amplifier

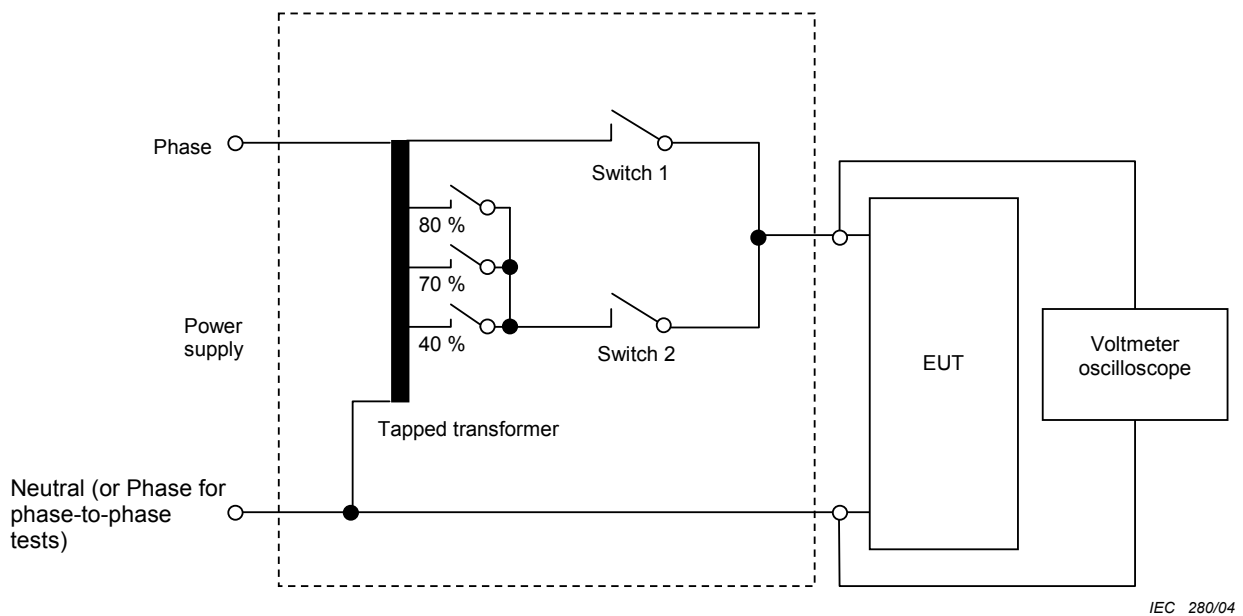

Figure C.1c) – Schematic of test instrumentation for voltage dips, short interruptions and voltage variations using tapped transformer and switches

Figure C.1 – Schematics of test instrumentation for voltage dips, short interruptions and voltage variations

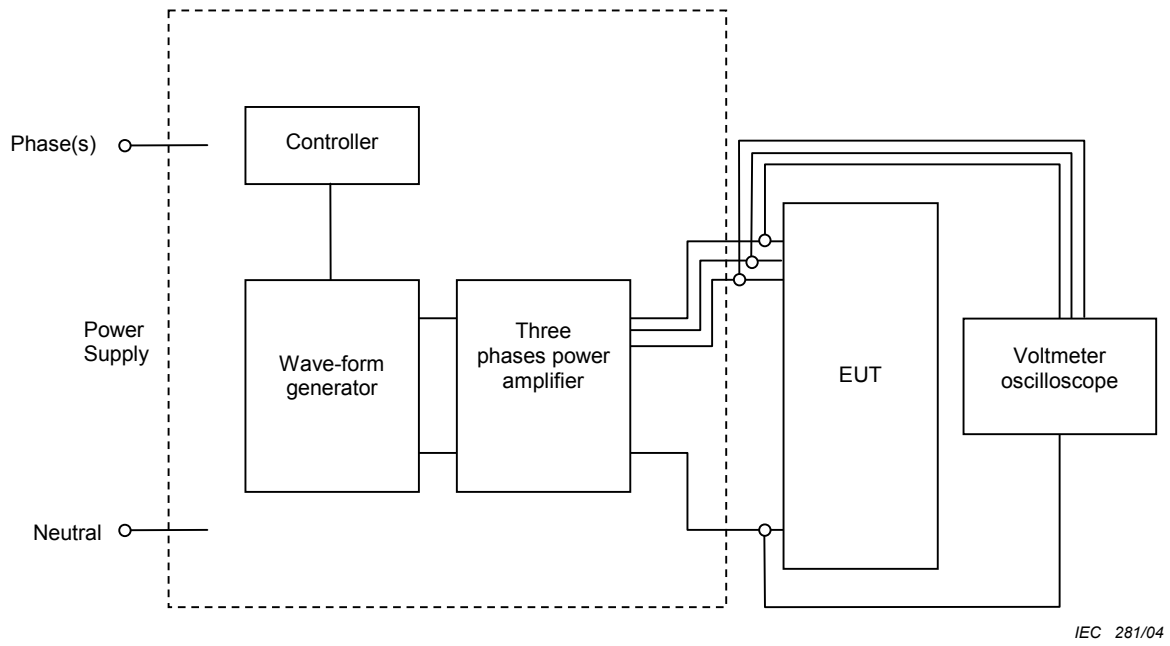

Figure C.2 – Schematic of test instrumentation for three-phase voltage dips, short interruptions and voltage variations using power amplifier

Bibliography

IEC 60050(161):1990, *International Electrotechnical Vocabulary (IEV) – Chapter 161 – Electromagnetic compatibility*

IEC 61000-2-4, *Electromagnetic compatibility (EMC) – Part 2-4: Environment – Compatibility levels in industrial plants for low-frequency conducted disturbances*

IEC 61000-4-14, *Electromagnetic compatibility (EMC) – Part 4-14: Testing and measurement techniques – Voltage fluctuation immunity test*
