

มาตรฐานผลิตภัณฑ์อุตสาหกรรม

THAI INDUSTRIAL STANDARD

มอก. 1467– 2550

ECE Regulation No.14

06 series of amendments

จุดยึดเข็มขัดนิรภัย ระบบยึดแบบไอโซฟิก และจุดยึดไอโซฟิกทอปเทเทอร์

SAFETY - BELT ANCHORAGES, ISOFIX ANCHORAGES SYSTEMS AND
ISOFIX TOP TETHER ANCHORAGES

สำนักงานมาตรฐานผลิตภัณฑ์อุตสาหกรรม

กระทรวงอุตสาหกรรม

ICS 43.040.99

ISBN 978-974-292-498-0

มาตรฐานผลิตภัณฑ์อุตสาหกรรม
จุดยึดเข็มขัดนิรภัย ระบบยึดแบบไอโซฟิก
และจุดยึดไอโซฟิกทอปเทเทอร์

มอก. 1467 – 2550

สำนักงานมาตรฐานผลิตภัณฑ์อุตสาหกรรม
กระทรวงอุตสาหกรรม ถนนพระรามที่ 6 กรุงเทพฯ 10400
โทรศัพท์ 0 2202 3300

ประกาศในราชกิจจานุเบกษา ฉบับประกาศและงานทั่วไป เล่ม 125 ตอนพิเศษ 99 ง
วันที่ 13 มิถุนายน พุทธศักราช 2551

มาตรฐานผลิตภัณฑ์อุตสาหกรรมจุดยึดเข็มขัดนิรภัย ระบบยึดแบบไอโซฟิกและจุดยึดไอโซฟิกทอปเทเทอร์ ได้ประกาศครั้งแรกเป็นมาตรฐานผลิตภัณฑ์อุตสาหกรรม จุดยึดเข็มขัดนิรภัยของรถยนต์ : เฉพาะด้านความปลอดภัย มาตรฐานเลขที่ มอก.1467-2540 ในราชกิจจานุเบกษา เล่ม 115 ตอนที่ 84ง วันที่ 20 ตุลาคม พุทธศักราช 2541 ต่อมาพิจารณาเห็นสมควรแก้ไขปรับปรุงสาระสำคัญของมาตรฐานผลิตภัณฑ์อุตสาหกรรมนี้ เพื่อให้สอดคล้องตาม มาตรฐานระหว่างประเทศที่เป็นที่ยอมรับจึงได้แก้ไขปรับปรุงโดยยกเลิกมาตรฐานเดิมและกำหนดมาตรฐานนี้ขึ้นใหม่ มาตรฐานผลิตภัณฑ์อุตสาหกรรมนี้กำหนดขึ้นโดยรับ Economic Commission for Europe (ECE) Regulation No.14 UNIFORM PROVISIONS CONCERNING THE APPROVAL OF VEHICLES WITH REGARD TO SAFETY - BELT ANCHORAGES , ISOFIX ANCHORAGES SYSTEMS AND ISOFIX TOP TETHER ANCHORAGES ดังต่อไปนี้

1. Regulation No. 14 Revision 4

Incorporating

Supplement 4 to 05 series of amendments

06 series of amendments

Supplement 5 to 05 series of amendments

Corrigendum 1 to Supplement 4 to 05 series of amendments

Corrigendum 1 to 06 series of amendments

Supplement 1 to 06 series of amendments

Corrigendum 2 to 06 series of amendments

Supplement 2 to 06 series of amendments

Corrigendum 1 to Revision 3 of the Regulation

Corrigendum 3 to 06 series of amendments

มาใช้ในระดับเหมือนกันทุกประการ (identical) เฉพาะสาระสำคัญทางวิชาการซึ่งแสดงถึงข้อกำหนด คุณลักษณะ และการทดสอบของจุดยึดเข็มขัดนิรภัย ระบบยึดแบบไอโซฟิกและจุดยึดไอโซฟิกทอปเทเทอร์

สำหรับข้อกำหนดด้านการรับรอง หรือการดำเนินการต่าง ๆ ที่เกี่ยวข้องให้เป็นไปตามพระราชบัญญัติมาตรฐาน ผลิตภัณฑ์อุตสาหกรรม โดยสำนักงานมาตรฐานผลิตภัณฑ์อุตสาหกรรม จะประกาศกำหนดหลักเกณฑ์การรับรองต่อไป

คณะกรรมการมาตรฐานผลิตภัณฑ์อุตสาหกรรมได้พิจารณามาตรฐานนี้แล้ว เห็นสมควรเสนอรัฐมนตรีประกาศตาม มาตรา 15 แห่งพระราชบัญญัติมาตรฐานผลิตภัณฑ์อุตสาหกรรม พ.ศ. 2511



ประกาศกระทรวงอุตสาหกรรม

ฉบับที่ 3840 (พ.ศ. 2551)

ออกตามความในพระราชบัญญัติมาตรฐานผลิตภัณฑ์อุตสาหกรรม

พ.ศ. 2511

เรื่อง ยกเลิกมาตรฐานผลิตภัณฑ์อุตสาหกรรม

จุดยึดเข็มขัดนิรภัยของรถยนต์ : เฉพาะด้านความปลอดภัย

และกำหนดมาตรฐานผลิตภัณฑ์อุตสาหกรรม

จุดยึดเข็มขัดนิรภัย ระบบยึดแบบไอโซฟิกและจุดยึดไอโซฟิกทอปเทเทอร์

โดยเป็นการสมควรปรับปรุงมาตรฐานผลิตภัณฑ์อุตสาหกรรม จุดยึดเข็มขัดนิรภัยของรถยนต์ : เฉพาะด้านความปลอดภัย มาตรฐานเลขที่ มอก.1467-2540

อาศัยอำนาจตามความในมาตรา 15 แห่งพระราชบัญญัติมาตรฐานผลิตภัณฑ์อุตสาหกรรม พ.ศ. 2511 รัฐมนตรีว่าการกระทรวงอุตสาหกรรมออกประกาศยกเลิกประกาศกระทรวงอุตสาหกรรม ฉบับที่ 2387 (พ.ศ.2541) ออกตามความในพระราชบัญญัติมาตรฐานผลิตภัณฑ์อุตสาหกรรม พ.ศ.2511 เรื่อง กำหนดมาตรฐานผลิตภัณฑ์อุตสาหกรรม จุดยึดเข็มขัดนิรภัยของรถยนต์ : เฉพาะด้านความปลอดภัย ลงวันที่ 14 สิงหาคม พ.ศ.2541 และออกประกาศกำหนดมาตรฐานผลิตภัณฑ์อุตสาหกรรม จุดยึดเข็มขัดนิรภัย ระบบยึดแบบไอโซฟิกและจุดยึดไอโซฟิกทอปเทเทอร์ มาตรฐานเลขที่ มอก.1467-2550 ขึ้นใหม่ ดังมีรายละเอียดต่อท้ายประกาศนี้

ทั้งนี้ ให้มีผลเมื่อพ้นกำหนด 30 วัน นับแต่วันถัดจากวันที่ประกาศในราชกิจจานุเบกษา เป็นต้นไป

ประกาศ ณ วันที่ 4 เมษายน พ.ศ. 2551

สุวิทย์ คุณกิตติ

รัฐมนตรีว่าการกระทรวงอุตสาหกรรม

มาตรฐานผลิตภัณฑ์อุตสาหกรรม จุดยึดเข็มขัดนิรภัย ระบบยึดแบบไอโซฟิกและจุดยึดไอโซฟิก ทอปเทเทอร์

ขอบข่าย

มาตรฐานผลิตภัณฑ์อุตสาหกรรมนี้ครอบคลุมจุดยึดเข็มขัดนิรภัยสำหรับที่นั่งของผู้ใหญ่ซึ่งหันหน้าไปด้านหน้าหรือด้านหลัง ในยานยนต์ประเภท M และ N ^{1/}

รวมถึงระบบยึดแบบไอโซฟิกและจุดยึดไอโซฟิกทอปเทเทอร์ซึ่งทำเพื่อยึดที่นั่งของเด็กในยานยนต์ประเภท M1 ยานยนต์ประเภท N1 ที่ติดตั้งจุดยึดไอโซฟิกให้เป็นไปตามมาตรฐานผลิตภัณฑ์อุตสาหกรรมนี้ด้วย

บทนิยาม

ความหมายของคำที่ใช้ในมาตรฐานผลิตภัณฑ์อุตสาหกรรมนี้ให้เป็นไปตาม ECE Regulation No.14

ข้อกำหนด

ข้อกำหนดคุณลักษณะในมาตรฐานผลิตภัณฑ์อุตสาหกรรมนี้ให้เป็นไปตาม ECE Regulation No.14 ข้อ 5.

การทดสอบ

การทดสอบและการหาค่าต่าง ๆ ในมาตรฐานผลิตภัณฑ์อุตสาหกรรมนี้ ให้เป็นไปตาม ECE Regulation No.14 ข้อ 6. ข้อ 7. และ ANNEX ที่เกี่ยวข้อง

^{1/} เป็นไปตาม the Consolidated Resolution (R.E.3,annex 7), document

TRANS/WP29/78/Rev.1/Amend.2,as last amended by Amend.4.

พอก. 1467-2550
ECE Regulation No.14
06 series of amendments

Regulation No. 14

UNIFORM PROVISIONS CONCERNING THE APPROVAL OF VEHICLES WITH REGARD
TO SAFETY-BELT ANCHORAGES, ISOFIX ANCHORAGES SYSTEMS
AND ISOFIX TOP TETHER ANCHORAGES

CONTENTS

REGULATION	<u>Page</u>
1. Scope	5
2. Definitions	5
3. Application for approval	9
4. Approval	10
5. Specifications	12
6. Tests	22
7. Inspection during and after static tests for safety-belt anchorages	30
8. Modifications and extension of approval of the vehicle type	31
9. Conformity of production	32
10. Penalties for non-conformity of production	32
11. Operating instructions	32
12. Production definitely discontinued	33
13. Names and addresses of technical services conducting approval tests, and of administrative departments	33
14. Transitional provisions	33

ANNEXES

Annex 1 - Communication concerning the approval (or extension, or refusal, or withdrawal, or production definitely discontinued) of a vehicle type with regard to safety-belt anchorages and ISOFIX anchorages systems and ISOFIX top tether anchorage if any pursuant to Regulation No. 14.

Annex 2 - Arrangements of the approval mark

Annex 3 - Location of effective belt anchorages

Annex 4 - Procedure for determining the "H" point and the actual torso angle for seating positions in motor vehicles

Appendix 1 - Description of the three-dimensional "H" point machine

Appendix 2 - Three-dimensional reference system

Appendix 3 - Reference data concerning seating positions

Annex 5 - Traction device

Annex 6 - Minimum number of anchorage points and location of lower anchorages

Appendix 1 - Location of lower anchorages – angle requirements only

Annex 7 - Dynamic test as an alternative to the safety-belt anchorages static strength test

Annex 8 - Dummy specifications

Annex 9 - ISOFIX anchorages systems and ISOFIX top tether anchorages

1. SCOPE

This Regulation applies to anchorages for safety-belts intended for adult occupants of forward-facing or rearward-facing seats in vehicles of categories M and N. 1/

It also applies to ISOFIX anchorages systems and ISOFIX top tether anchorages intended to ISOFIX child restraint systems installed in vehicles of category M₁. N₁ vehicles fitted with ISOFIX anchorages have also to comply with the provisions of this Regulation.

2. DEFINITIONS

For the purposes of this Regulation,

- 2.1. "Approval of a vehicle" means the approval of a vehicle type equipped with anchorages for given types of safety-belts;
- 2.2. "Vehicle type" means a category of power-driven vehicles, which do not differ in such essential respects as the dimensions, lines and materials of components of the vehicle structure or seat structure to which the safety-belts anchorages and the ISOFIX anchorages systems and ISOFIX top tether anchorages if any are attached and, if the anchorages strength is tested according to the dynamic test, the characteristics of any component of the restraint system, especially the load limiter function, having an influence on the forces applying to the safety-belt anchorages.
- 2.3. "Belt anchorages" means the parts of the vehicle structure or the seat structure or any other part of the vehicle to which the safety-belt assemblies are to be secured;
- 2.4. "Effective belt anchorage" means the point used to determine conventionally, as specified in paragraph 5.4., the angle of each part of the safety-belt in relation to the wearer, that is, the point to which a strap would need to be attached to provide the same lie as the intended lie of the belt when worn, and which may or may not be the actual belt anchorage depending on the configuration of the safety-belt hardware at its attachment to the belt anchorage.
- 2.4.1. For example, in the case
- 2.4.1.1. where a strap guide is used on the vehicle structure or on the seat structure, the middle point of the guide at the place where the strap leaves the guide on the belt wearer's side, shall be considered as the effective belt anchorage; and,

1/ As defined in the Consolidated Resolution (R.E.3, annex 7), document TRANS/WP29/78/Rev.1/Amend.2, as last amended by Amend.4.

page 6

- 2.4.1.2. where the belt runs directly from the wearer to a retractor attached to the vehicle structure or the seat structure without an intervening strap guide, the effective belt anchorage shall be considered as being the intersection of the axis of the reel for storing the strap with the plane passing through the centre line of the strap on the reel;
- 2.5. "Floor" means the lower part of the vehicle body-work connecting the vehicle side walls. In this context it includes ribs, swages and possibly other reinforcements, even if they are below the floor, such as longitudinal and transverse members;
- 2.6. "Seat" means a structure which may or may not be integral with the vehicle structure complete with trim, intended to seat one adult person. The term covers both an individual seat or part of a bench seat intended to seat one person;
- 2.6.1. "Front passenger seat" means any seat where the "foremost H point" of the seat in question is in or in front of the vertical transverse plane through the driver's R point;
- 2.7. "Group of seats" means either a bench-type seat, or seats which are separate but side by side (i.e. with the foremost anchorages of one seat in line with or forward of the rearmost anchorages and in line with or behind the foremost anchorages of another seat) and accommodate one or more seated adult person;
- 2.8. "Bench seat" means a structure complete with trim, intended to seat more than one adult person;
- 2.9. "Folding seat" means an auxiliary seat intended for occasional use which is normally folded;
- 2.10. "Seat type" means a category of seats which do not differ in such essential respects as:
- 2.10.1. the shape, dimensions and materials of the seat structure,
- 2.10.2. the types and dimensions of the adjustment systems and all locking systems,
- 2.10.3. the type and dimensions of the belt anchorages on the seat, of the seat anchorage and of the affected parts of the vehicle structure;
- 2.11. "Seat anchorage" means the system by which the seat assembly is secured to the vehicle structure, including the affected parts of the vehicle structure;
- 2.12. "Adjustment system" means the device by which the seat or its parts can be adjusted to a position suited to the morphology of the seated occupant; this device may, in particular, permit of:

- 2.12.1. longitudinal displacement;
- 2.12.2. vertical displacement;
- 2.12.3. angular displacement;
- 2.13. "Displacement system" means a device enabling the seat or one of its parts to be displaced or rotated without a fixed intermediate position, to permit easy access to the space behind the seat concerned;
- 2.14. "Locking system" means any device ensuring that the seat and its parts are maintained in any position of use and includes devices to lock both the seat back relative to the seat and the seat relative to the vehicle.
- 2.15. "Reference zone" means the space between two vertical longitudinal planes, 400 mm apart and symmetrical with respect to the H point, and defined by rotation from vertical to horizontal of the headform apparatus, as described in Regulation No. 21, annex 1. The apparatus shall be positioned as described in that annex to Regulation No. 21 and set to the maximum length of 840 mm.
- 2.16. "Thorax load limiter function" means any part of the safety-belt and/or the seat and/or the vehicle intended to limit the level of the restraint forces applying to the occupant thorax in case of a collision.
- 2.17. "ISOFIX" is a system for the connection of child restraint systems to vehicles which has two vehicle rigid anchorages, two corresponding rigid attachments on the child restraint system and a mean to limit the pitch rotation of the child restraint system.
- 2.18. "ISOFIX position" means a system which allows to install:
- (a) either an universal ISOFIX forward facing child restraint system as defined in Regulation No. 44,
 - (b) or a semi-universal ISOFIX forward facing child restraint system as defined in Regulation No. 44,
 - (c) or a semi-universal ISOFIX rearward facing child restraint system as defined in Regulation No. 44,
 - (d) or a semi-universal ISOFIX lateral facing position child restraint system as defined in Regulation No. 44,
 - (e) or a specific vehicle ISOFIX child restraint system as defined in Regulation No. 44.

page 8

- 2.19. "ISOFIX low anchorage" means one 6 mm diameter rigid round horizontal bar, extending from vehicle or seat structure to accept and restrain an ISOFIX child restraint system with ISOFIX attachments.
- 2.20. "ISOFIX anchorages system" means a system made up of two ISOFIX low anchorages which is designed for attaching an ISOFIX child restraint system in conjunction with an anti-rotation device.
- 2.21. "ISOFIX attachment" means one of the two connections, fulfilling the requirements of Regulation No. 44, extending from the ISOFIX child restraint system structure, and compatible with an ISOFIX low anchorage.
- 2.22. "ISOFIX child restraint system" means a child restraint system, fulfilling the requirements of Regulation No. 44, which has to be attached to an ISOFIX anchorages system.
- 2.23. "Static force application device (SFAD)" means a test fixture that engages the vehicle ISOFIX anchorages systems and that is used to verify their strength and the ability of the vehicle or seat structure to limit the rotation in a static test. The test fixture is described in the figures 1 and 2 annex 9.
- 2.24. "Anti-rotation device"
- (a) An anti-rotation device for an ISOFIX universal child restraint system consists of the ISOFIX top-tether.
 - (b) An anti-rotation device for an ISOFIX semi-universal child restraint system consists of either a top tether, the vehicle dashboard or a support leg intended to limit the rotation of the restraint during a frontal impact.
 - (c) For ISOFIX, universal and semi-universal, child restraint systems the vehicle seat itself does not constitute an anti-rotation device.
- 2.25. "ISOFIX top tether anchorage" means a feature, such as a bar, located in a defined zone, designed to accept an ISOFIX top tether strap connector and transfer its restraint force to the vehicle structure.
- 2.26. "ISOFIX top tether connector" means a device intended to be attached to an ISOFIX top tether anchorage.
- 2.27. "ISOFIX top tether hook" means an ISOFIX top tether connector typically used to attach an ISOFIX top tether strap to an ISOFIX top tether anchorage as defined in figure 3 of annex 9 of this Regulation.

- 2.28. "ISOFIX top tether strap" means a webbing strap (or equivalent) which extends from the top of an ISOFIX child restraint system to the ISOFIX top tether anchorage, and which is equipped with an adjustment device, a tension-relieving device, and an ISOFIX top tether connector.
- 2.29. "A guidance device" is intended to help the person installing the ISOFIX child restraint system by physically guiding the ISOFIX attachments on the ISOFIX child restraint into correct alignment with the ISOFIX low anchorages to facilitate engagement.
- 2.30. "ISOFIX marking fixture" means something that informs someone wishing to install an ISOFIX child restraint system of the ISOFIX positions in the vehicle and the position of each ISOFIX corresponding ISOFIX anchorages systems.
- 2.31. "A child restraint fixture" means a fixture according to one out of the seven ISOFIX size classes defined in paragraph 4. of annex 17 – appendix 2 of Regulation No. 16 and particularly whose dimensions are given from figure 1 to figure 7 in the previous mentioned paragraph 4. Those child restraint fixtures (CRF) are used in Regulation No. 16, to check what are the ISOFIX child restraint systems size classes which can be accommodated on the vehicle ISOFIX positions. Also one of the CRF, the so-called ISO/F2 (B) which is described in figure 2 of the previous mentioned paragraph 4., is used in this Regulation to check the location and the possibility of access to any ISOFIX anchorages system.

3. APPLICATION FOR APPROVAL

- 3.1. The application for approval of a vehicle type with regard to the belt anchorages, the ISOFIX anchorages systems and the ISOFIX top tether anchorages if any shall be submitted by the vehicle manufacturer or by his duly accredited representative.
- 3.2. It shall be accompanied by the undermentioned documents in triplicate and by the following particulars:
- 3.2.1. drawings of the general vehicle structure on an appropriate scale, showing the positions of the belt anchorages, of the effective belt anchorages (where appropriate), of the ISOFIX anchorages systems and of ISOFIX top tether anchorages if any and detailed drawings of the belt anchorages, of the ISOFIX anchorages systems if any, of the ISOFIX top tether anchorage if any, and of the points to which they are attached;
- 3.2.2. a specification of the materials used which may affect the strength of the belt anchorages, of the ISOFIX anchorages systems and ISOFIX top tether anchorages if any;

page 10

- 3.2.3. a technical description of the belt anchorages, of the ISOFIX anchorages systems and ISOFIX top tether anchorages if any;
- 3.2.4. in the case of belt anchorages, of the ISOFIX anchorages systems and of ISOFIX top tether anchorages if any affixed to the seat structure:
 - 3.2.4.1. detailed description of the vehicle type with regard to the design of the seats, of the seat anchorages and of their adjustment and locking systems;
 - 3.2.4.2. drawings, on an appropriate scale and in sufficient detail, of the seats, of their anchorage to the vehicle, and of their adjustment and locking systems.
- 3.2.5. evidence that the safety-belt or the restraint system used in the anchorages approval test complies with Regulation No. 16, in the case where the car manufacturer chooses the alternative dynamic strength test.
- 3.3. At the option of the manufacturer, a vehicle representative of the vehicle type to be approved or the parts of the vehicle considered essential for the belt anchorages test, for the ISOFIX anchorages systems and for ISOFIX top tether anchorages test if any, by the technical service conducting approval tests shall be submitted to the service.
4. APPROVAL
 - 4.1. If the vehicle submitted for approval pursuant to this Regulation meets the relevant requirements of this Regulation, approval of that vehicle type shall be granted.
 - 4.2. An approval number shall be assigned to each type approved. Its first two digits (at present 06, corresponding to the 06 series of amendments) shall indicate the series of amendments incorporating the most recent major technical amendments made to the Regulation at the time of issue of the approval. The same Contracting Party may not assign the same number to another vehicle type as defined in paragraph 2.2. above.
 - 4.3. Notice of approval or of extension or refusal or withdrawal of approval or production definitely discontinued of a vehicle type pursuant to this Regulation shall be communicated to the Parties to the 1958 Agreement which apply this Regulation by means of a form conforming to the model in annex 1 to the Regulation.
 - 4.4. There shall be affixed, conspicuously and in a readily accessible place specified on the approval form, to every vehicle conforming to a vehicle type approved under this Regulation an international approval mark consisting of:

- 4.4.1. a circle surrounding the letter "E" followed by the distinguishing number of the country which has granted approval; 2/
- 4.4.2. the number of this Regulation, to the right of the circle prescribed in paragraph 4.4.1.
- 4.4.3. the letter "e", to the right of the number of this Regulation in the case of type approval according to the dynamic test of annex 7.
- 4.5. If the vehicle conforms to a vehicle type approved, under one or more other Regulations annexed to the Agreement, in the country which has granted approval under this Regulation, the symbol prescribed in paragraph 4.4.1. need not be repeated; in such a case the additional numbers and symbols of all the Regulations under which approval has been granted in the country which has granted approval under this Regulation shall be placed in vertical columns to the right of the symbol prescribed in paragraph 4.4.1.
- 4.6. The approval mark shall be clearly legible and be indelible.
- 4.7. The approval mark shall be placed close to or on the vehicle data plate affixed by the manufacturer.
- 4.8. Annex 2 to this Regulation gives examples of arrangements of the approval mark.

2/ 1 for Germany, 2 for France, 3 for Italy, 4 for the Netherlands, 5 for Sweden, 6 for Belgium, 7 for Hungary, 8 for the Czech Republic, 9 for Spain, 10 for Serbia and Montenegro, 11 for the United Kingdom, 12 for Austria, 13 for Luxembourg, 14 for Switzerland, 15 (vacant), 16 for Norway, 17 for Finland, 18 for Denmark, 19 for Romania, 20 for Poland, 21 for Portugal, 22 for the Russian Federation, 23 for Greece, 24 for Ireland, 25 for Croatia, 26 for Slovenia, 27 for Slovakia, 28 for Belarus, 29 for Estonia, 30 (vacant), 31 for Bosnia and Herzegovina, 32 for Latvia, 33 (vacant), 34 for Bulgaria, 35 (vacant), 36 for Lithuania, 37 for Turkey, 38 (vacant), 39 for Azerbaijan, 40 for The former Yugoslav Republic of Macedonia, 41 (vacant), 42 for the European Community (Approvals are granted by its Member States using their respective ECE symbol), 43 for Japan, 44 (vacant), 45 for Australia, 46 for Ukraine, 47 for South Africa, 48 for New Zealand, 49 for Cyprus, 50 for Malta, 51 for the Republic of Korea, 52 for Malaysia and 53 for Thailand. Subsequent numbers shall be assigned to other countries in the chronological order in which they ratify or accede to the Agreement Concerning the Adoption of Uniform Technical Prescriptions for Wheeled Vehicles, Equipment and Parts which can be Fitted and/or be Used on Wheeled Vehicles and the Conditions for Reciprocal Recognition of Approvals Granted on the Basis of these Prescriptions, and the numbers thus assigned shall be communicated by the Secretary-General of the United Nations to the Contracting Parties to the Agreement.

page 12

5. SPECIFICATIONS

5.1. Definitions (see annex 3)

5.1.1. The H point is a reference point as defined in paragraph 2.3. of annex 4 of this Regulation, which must be determined in accordance with the procedure set out in that annex.

5.1.1.1. Point H' is a reference point corresponding to H as defined in paragraph 5.1.1. which shall be determined for every normal position in which the seat is used.

5.1.1.2. The R point is the seating reference point defined in paragraph 2.4. of annex 4 of this Regulation.

5.1.2. The three-dimensional reference system is defined in appendix 2 of annex 4 of this Regulation.

5.1.3. Points L_1 and L_2 are the lower effective belt anchorages.

5.1.4. Point C is a point situated 450 mm vertically above the R point. However, if the distance S as defined in paragraph 5.1.6. is not less than 280 mm and if the alternative formula $BR = 260 \text{ mm} + 0.8 S$ specified in paragraph 5.4.3.3. is chosen by the manufacturer, the vertical distance between C and R shall be 500 mm.

5.1.5. The angles α_1 and α_2 are respectively the angles between a horizontal plane and planes perpendicular to the median longitudinal plane of the vehicle and passing through the point H_1 and the points L_1 and L_2 .

5.1.6. S is the distance in millimetres of the effective upper belt anchorages from a reference plane P parallel to the longitudinal median plane of the vehicle defined as follows:

5.1.6.1. if the seating position is well-defined by the shape of the seat, the plane P shall be the median plane of this seat.

5.1.6.2. in the absence of a well-defined position:

5.1.6.2.1. the plane P for the driver's seat is a vertical plane parallel to the median longitudinal plane of the vehicle which passes through the centre of the steering-wheel in the plane of the steering-wheel rim when the steering-wheel, if adjustable, is in its central position.

5.1.6.2.2. the plane P for the front outboard passenger shall be symmetrical with that of the driver.

5.1.6.2.3. The plane P for the rear outboard seating position shall be that specified by the manufacturer on condition the following limits for distance A between the longitudinal median plane of the vehicle and plane P are respected:

A is equal or more than 200 mm if the bench seat has been designed to accommodate two passengers only,

A is equal or more than 300 mm if the bench seat has been designed to accommodate more than two passengers.

5.2. General specifications

5.2.1. Anchorages for safety-belts shall be so designed, made and situated as to:

5.2.1.1. enable the installation of a suitable safety-belt. The belt anchorages of the front outboard positions shall be suitable for safety-belts incorporating a retractor and pulley, taking into consideration in particular the strength characteristics of the belt anchorages, unless the manufacturer supplies the vehicle equipped with other types of safety-belts which incorporate retractors. If the anchorages are suitable only for particular types of safety-belts, these types shall be stated on the form mentioned in paragraph 4.3. above;

5.2.1.2. reduce to a minimum the risk of the belt's slipping when worn correctly;

5.2.1.3. reduce to a minimum the risk of strap damage due to contact with sharp rigid parts of the vehicle or seat structures;

5.2.1.4. enable the vehicle, in normal use, to comply with the provisions of this Regulation;

5.2.1.5. for anchorages which take up different positions to allow persons to enter the vehicle and to restrain the occupants, the specifications of this Regulation shall apply to the anchorages in the effective restraint position.

5.2.2. Any ISOFIX anchorages system and any ISOFIX top tether anchorage, installed or intended to be installed, for ISOFIX child restraint systems shall be so designed, made and situated as to:

5.2.2.1. Any ISOFIX anchorages system and any top tether anchorage shall enable the vehicle, in normal use, to comply with the provisions of this Regulation.

Any ISOFIX anchorages system and ISOFIX top tether anchorage which could be added on any vehicle shall also comply with the provisions of this Regulation. Consequently, such anchorages shall be described on the application document for type approval.

page 14

- 5.2.2.2. ISOFIX anchorages system and ISOFIX top tether anchorage resistance are designed for any ISOFIX child restraint systems of group of mass 0; 0+; 1 as defined in Regulation No. 44.
- 5.2.3. ISOFIX anchorage systems, design and positioning:
- 5.2.3.1. Any ISOFIX anchorages system shall be 6 mm \pm 0.1 mm diameter transverse horizontal rigid bar(s) which cover(s) two zones of 25 mm minimum effective length located on the same axis as defined in figure 4 annex 9.
- 5.2.3.2. Any ISOFIX anchorages system installed on a vehicle seating position shall be located not less than 120 mm behind the design H-point as determined in annex 4 to this Regulation, measured horizontally and up to the centre of the bar.
- 5.2.3.3. For any ISOFIX anchorages system installed in the vehicle, it shall be verified the possibility to attach the ISOFIX child restraint fixture "ISO/F2" (B) described in Regulation No. 16 (annex 17, appendix 2, figure 2).
- 5.2.3.4. The bottom surface of the fixture "ISO/F2" (B) as defined in Regulation No. 16 (annex 17, appendix 2, figure 2), shall have attitude angles within the following limits, angles measured relatively to the vehicle reference planes as defined in annex 4 appendix 2 to this Regulation:
- (a) Pitch: $15^\circ \pm 10^\circ$,
 - (b) Roll: $0^\circ \pm 5^\circ$,
 - (c) Yaw: $0^\circ \pm 10^\circ$
- 5.2.3.5. ISOFIX anchorage systems shall be permanently in position or storable. In case of storable anchorages, the requirements relating to ISOFIX anchorages system shall be fulfilled in the deployed position.
- 5.2.3.6. Each ISOFIX low anchorage bar (when deployed for use) or each permanently installed guidance device shall be visible, without the compression of the seat cushion or seat back, when the bar or the guidance device is viewed, in a vertical longitudinal plane passing through the centre of the bar or of the guidance device, along a line making an upward angle of 30 degrees with a horizontal plane.
- As an alternative to the above requirement, the vehicle shall be permanently marked adjacent to each bar or guidance device. This marking shall consist in one of the following, at the choice of the manufacturer."
- 5.2.3.6.1. As a minimum, the symbol of annex 9, figure 12 consisting of a circle with a diameter of minimum 13 mm and containing a pictogram, meeting the following conditions:

- (a) the pictogram shall contrast with the background of the circle;
- (b) the pictogram shall be located close to each bar of the system;

5.2.3.6.2. The word "ISOFIX" in capital letters of at least 6 mm height.

5.2.4. ISOFIX top tether anchorages, design and positioning:

At the request of the car manufacturer, methods described in paragraphs 5.2.4.1. and 5.2.4.2. can be used alternatively.

Method described in paragraph 5.2.4.1. can only be used if the ISOFIX position is located on a vehicle seat.

5.2.4.1. Subject to paragraphs 5.2.4.3. and 5.2.4.4., the portion of each ISOFIX top tether anchorage that is designed to bind with an ISOFIX top tether connector shall be located not further than 2000 mm far from the shoulder reference point and within the shaded zone, as shown in figures 6 to 10 of annex 9, of the designated seating position for which it is installed, with the reference of a template described in SAE J 826 (July 1995) and shown in annex 9, figure 5, according to the following conditions:

5.2.4.1.1. The "H" point of the template is located at the unique design "H" point of the full downward and full rearward position of the seat, except that the template is located laterally midway between the two ISOFIX lower anchorages;

5.2.4.1.2. The torso line of the template is at the same angle to the transverse vertical plane as the seat back in its most upright position, and

5.2.4.1.3. The template is positioned in the vertical longitudinal plane that contains the H-point of the template.

5.2.4.2. The ISOFIX top tether anchorage zone may be alternatively located with the aid of the Fixture "ISO/F2" (B), as defined in Regulation No. 16 (annex 17, appendix 2, figure 2), in an ISOFIX position equipped with ISOFIX low anchorages as shown in figure 11 of annex 9.

The seating position shall be the seat's rearmost, downmost position with the seat back in its nominal position, or as recommended by the vehicle manufacturer.

In the side view, the ISOFIX top tether anchorage shall lie behind the "ISO/F2" (B) fixture rear face.

The intersection between the "ISO/F2" (B) fixture rear face and the horizontal line (annex 9, figure 11, reference 3) containing the last rigid point of a hardness greater than 50 Shore A at the top of the seat back defines the reference point 4

(annex 9, figure 11) on the centreline of the "ISO/F2" (B) fixture. At this reference point, a maximum angle of 45° above the horizontal line defines the upper limit of the top tether anchorage zone.

In the top view, at the reference point 4 (annex 9, figure 11), a maximum angle of 90° extending rearward and laterally and in the rear view, a maximum angle of 40° defines 2 volumes which limit the anchorage zone for the ISOFIX top tether.

The origin of the ISOFIX top tether strap (5) is located at the intersection of the "ISO/F2" (B) fixture with a plane 550 mm distant above the "ISO/F2" (B) fixture horizontal face (1) on the "ISO/F2" (B) fixture centreline (6).

Further, the ISOFIX top tether anchorage shall be more than 200 mm but not more than 2000 mm from the origin of the ISOFIX top tether strap on the rear face of the "ISO/F2" (B) fixture, measured along the strap when it is drawn over the seat back to the ISOFIX top tether anchorage.

- 5.2.4.3. The portion of the ISOFIX top tether anchorage in a vehicle that is designed to bind with the ISOFIX top tether connector may be located outside the shaded zones referred to paragraphs 5.2.4.1. or 5.2.4.2. if a location within a zone is not appropriate and the vehicle is equipped with a routing device that,
- 5.2.4.3.1. ensures that the ISOFIX top tether strap functions as if the portion of the anchorage designed to bind with the ISOFIX top tether anchorage were located within the shaded zone; and,
- 5.2.4.3.2. is at least 65 mm behind the torso line, in case of a non-rigid webbing-type routing device or a deployable routing device, or at least 100 mm behind the torso line, in the case of a fixed rigid routing device; and,
- 5.2.4.3.3. when tested after being installed as it is intended to be used, the device is of sufficient strength to withstand, with the ISOFIX top tether anchorage the load referred to in paragraph 6.6. of this Regulation.
- 5.2.4.4. A tether anchorage may be recessed in the seat back, provided that it is not in the strap wrap-around area at the top of the vehicle seat back.
- 5.2.4.5. The ISOFIX top tether anchorage shall have dimensions to permit the attachment of an ISOFIX top tether hook as specified in figure 3.

Clearance shall be provided around each ISOFIX top tether anchorage to allow latching and unlatching to it. For each ISOFIX top tether anchorage under a cover, the cover shall be identified by for example one of the symbols or the mirror image of one of the symbols set out in figure 13 of annex 9; the cover shall be removable without the use of tools.

5.3. Minimum number of belt anchorages to be provided

5.3.1. Any vehicle in categories M and N (except those vehicles of categories M₂ and M₃ which belong to Classes I or II, according to Regulation No. 36, to Class A, according to Regulation No. 52 and to Classes I or II and A, according to Regulation No. 107) must be equipped with safety-belt anchorages which satisfy the requirements of this Regulation.

5.3.1.1. The anchorages of a harness belt system approved as a S-type belt (with or without retractor(s)) according to Regulation No. 16 shall comply with the requirements of Regulation No. 14, but the additional anchorage or anchorages provided for the fitting of a crotch strap (assembly) are exempted from the strength and location requirements of this Regulation.

5.3.2. The minimum number of safety-belt anchorages for each forward and rearward directed seating position shall be those specified in annex 6.

5.3.3. However, for outboard seating positions, other than front, of vehicles of category N₁, shown in annex 6 and marked with the symbol Ø, two lower anchorages are allowed, where there exists a passage between a seat and the nearest side-wall of the vehicle intended to permit access of passengers to other parts of the vehicle.

A space between a seat and the side-wall is considered as a passage if the distance between that side-wall, with all doors closed, and a vertical longitudinal plane passing through the centre line of the seat concerned, measured at the R point position and perpendicularly to the median longitudinal plane of the vehicle is more than 500 mm.

5.3.4. For the front centre seating positions shown in annex 6 and marked with the symbol *, two lower anchorages shall be considered adequate where the windscreen is located outside the reference zone defined in annex 1 to Regulation No. 21; if located inside the reference zone, three anchorages are required.

As regards belt anchorages, the windscreen is considered as part of the reference zone when it is capable of entering into static contact with the test apparatus according to the method described in annex 1 to Regulation No. 21.

5.3.5. In every seating position marked in annex 6 with symbol $\frac{||}{||}$, three anchorages shall be provided. Two anchorages may be provided if one of the following conditions is fulfilled:

5.3.5.1. there is a seat or other parts of the vehicle conforming to Regulation No. 80, appendix 1, paragraph 3.5. directly in front, or

page 18

- 5.3.5.2. no part of the vehicle is in the reference zone, or capable of being in the reference zone when the vehicle is in motion, or
- 5.3.5.3. parts of the vehicle within the said reference zone comply with the energy absorbing requirements set out in Regulation No. 80, appendix 6.
- 5.3.6. For all folding seats, or seating intended solely for use when the vehicle is stationary as well as for all the seats of any vehicle which are not covered by paragraphs 5.3.1. to 5.3.4., no belt anchorages are required. However, if the vehicle is fitted with anchorages for such seats, these anchorages must comply with the provisions of this Regulation. In this case, two lower anchorages shall be sufficient.
- 5.3.7. In the case of the upper deck of a double-deck vehicle, the requirements for the centre front seating position shall apply also in the outboard front seating positions.
- 5.3.8. Minimum number of ISOFIX positions to be provided.
- 5.3.8.1. Any vehicle of category M₁ must be equipped at least with two ISOFIX positions.
- At least two of the ISOFIX positions shall be equipped both with an ISOFIX anchorages system and an ISOFIX top tether anchorage.
- The type and number of ISOFIX fixtures, defined in Regulation No. 16, which can be installed on each ISOFIX position are defined in Regulation No. 16.
- 5.3.8.2. Notwithstanding paragraph 5.3.8.1. if a vehicle is only equipped with one seat row, no ISOFIX position is required.
- 5.3.8.3. Notwithstanding paragraph 5.3.8.1. at least one of the two ISOFIX positions systems shall be installed at the second seat row.
- 5.3.8.4. If an ISOFIX anchorages system is installed at a front seating position protected with a frontal airbag, a de-activation device for this airbag shall be fitted.
- 5.3.8.5. Notwithstanding paragraph 5.3.8.1. in case of integrated "built in" child restraint system(s) the number of ISOFIX positions to be provided shall be at least two minus the number of the integrated "built in" child restraint system(s) of mass groups 0, or 0+, or 1.
- 5.3.8.6. Notwithstanding the provision of the paragraph 5.3.8.1., convertible vehicles as defined in annex 7, paragraph 8.1. of the Consolidated Resolution on the Construction of Vehicles (R.E.3) 3/ with more than one seat row shall be fitted with at least two ISOFIX low anchorages. In case where an ISOFIX top tether

3/ Document TRANS/WP29/78/Rev.1/Amend.2, as last amended by Amend.4.

anchorage is provided on such vehicles, it shall comply with the suitable provisions of this Regulation.

5.3.9. In the case of seats capable of being turned to or placed in other orientations, for use when the vehicle is stationary, the requirements of paragraph 5.3.1. shall apply only to those orientations designated for normal use when the vehicle is travelling on a road, in accordance with this Regulation. A note to this effect shall be included in the information document.

5.4. Location of belt anchorages (see annex 3, figure 1.)

5.4.1. General

5.4.1.1. The belt anchorages for any one belt may be located either wholly in the vehicle structure or in the seat structure or any other part of the vehicle or dispersed between these locations.

5.4.1.2. Any one belt anchorage may be used for attaching the ends of two adjacent safety-belts, provided that the test requirements are met.

5.4.2. Location of the effective lower belt anchorage

5.4.2.1. Front seats, vehicle category M₁

In motor vehicles of category M₁ the angle α_1 (other than buckle side) shall be within the range of 30 to 80 degrees and the angle α_2 (buckle side) shall be within the range of 45 to 80 degrees. Both angle requirements shall be valid for all normal travelling positions of the front seats. Where at least one of the angles α_1 and α_2 is constant (e.g. anchorage fixed at the seat) in all normal positions of use, its value shall be $60 \pm 10^\circ$. In the case of adjustable seats with an adjusting device as described in paragraph 2.12. with a seatback angle of less than 20° (see annex 3, figure 1), the angle α_1 may be below the minimum value (30°) stipulated above, provided it is not less than 20° in any normal position of use.

5.4.2.2. Rear seats, vehicle category M₁

In motor vehicles of category M₁ the angles α_1 and α_2 shall be within the range of 30 to 80 degrees for all rear seats. If rear seats are adjustable the above angles shall be valid for all normal travelling positions.

5.4.2.3. Front seats, vehicle categories other than M₁

In motor vehicles of categories other than M₁ the angles α_1 and α_2 must be between 30 and 80 degrees for all normal travelling positions of the front seats. Where in the case of front seats of vehicles having a maximum vehicle mass not

exceeding 3.5 tonnes at least one of the angles α_1 and α_2 is constant in all normal positions of use, its value shall be $60 \pm 10^\circ$ (e.g. anchorage fixed at the seat).

5.4.2.4. Rear seats and special front or rear seats, vehicle categories other than M₁

In vehicles of categories other than M₁, in the case of:

- (a) bench seats,
- (b) adjustable seats (front and rear) with an adjusting device as described in paragraph 2.12. with a seatback angle of less than 20° (see annex 3, figure 1), and
- (c) other rear seats

angles α_1 and α_2 may be between 20° and 80° in any normal position of use. Where in the case of front seats of vehicles having a maximum vehicle mass not exceeding 3.5 tonnes at least one of the angles α_1 and α_2 is constant in all normal positions of use, its value shall be $60 \pm 10^\circ$ (e.g. anchorage fixed at the seat).

In the case of seats, other than front seats, of vehicles in categories M₂ and M₃, the angles α_1 and α_2 shall be between 45 and 90 degrees for all normal positions of use.

5.4.2.5. The distance between the two vertical planes parallel to the median longitudinal plane of the vehicle and each passing through a different one of the two effective lower belt anchorages L₁ and L₂ of the same safety-belt shall not be less than 350 mm. In the case of any central seating positions in rear rows of seats of vehicles of category M₁ and N₁, the above-mentioned distance shall be not less than 240 mm, provided that it is not possible to exchange the centre rear seat with any of the other seats of the vehicle. The median longitudinal plane of the seat shall pass between points L₁ and L₂ and shall be at least 120 mm from these points.

5.4.3. Location of the effective upper belt anchorages (see annex 3)

5.4.3.1. If a strap guide or similar device is used which affects the location of the effective upper belt anchorage, this location shall be determined in a conventional way by considering the position of the anchorage when the longitudinal centre line of the strap passes through a point J₁ defined successively from the R point by the following three segments:

RZ: a segment of the torso line measured in an upward direction from R and 530 mm long;

ZX: a segment perpendicular to the median longitudinal plane of the vehicle, measured from point Z in the direction of the anchorage and 120 mm long;

XJ₁: a segment perpendicular to the plane defined by segments RZ and ZX, measured in a forward direction from point X and 60 mm long.

Point J₂ is determined by symmetry with point J₁ about the longitudinal vertical plane passing through the torso line described in paragraph 5.1.2. of the manikin positioned in the seat in question.

Where a two-door configuration is used to provide access to both the front and rear seats and the upper anchorage is fitted to the "B" post, the system must be designed so as not to impede access to or egress from the vehicle.

- 5.4.3.2. The effective upper anchorage shall lie below the plane FN, which runs perpendicular to the longitudinal median plane of the seat and makes an angle of 65° with the torso line. The angle may be reduced to 60° in the case of rear seats. The plane FN shall be so placed as to intersect the torso line at a point D such that $DR = 315 \text{ mm} + 1.8 S$. However, when $S \leq 200 \text{ mm}$, then $DR = 675 \text{ mm}$.
- 5.4.3.3. The effective upper belt anchorage shall lie behind a plane FK running perpendicular to the longitudinal median plane of the seat and intersecting the torso line at an angle of 120° at a point B such that $BR = 260 \text{ mm} + S$. Where $S \geq 280 \text{ mm}$, the manufacturer may use $BR = 260 \text{ mm} + 0.8 S$ at his discretion.
- 5.4.3.4. The value of S shall not be less than 140 mm.
- 5.4.3.5. The effective upper belt anchorage shall be situated to the rear of a vertical plane perpendicular to the median longitudinal plane of the vehicle and passing through the R point as shown in annex 3.
- 5.4.3.6. The effective upper belt anchorage shall be situated above a horizontal plane passing through point C defined in paragraph 5.1.4.
- 5.4.3.7. In addition to the upper anchorage specified in paragraph 5.4.3.1. other effective upper anchorages may be provided if one of the following conditions is satisfied:
- 5.4.3.7.1. The additional anchorages comply with the requirements of paragraphs 5.4.3.1. to 5.4.3.6.
- 5.4.3.7.2. The additional anchorages can be used without the aid of tools, comply with the requirements of paragraphs 5.4.3.5. and 5.4.3.6. and are located in one of the areas determined by shifting the area shown in figure 1 of annex 3 of this Regulation, 80 mm upwards or downwards in a vertical direction.

page 22

5.4.3.7.3. The anchorage(s) is/are intended for a harness belt, complies/comply with the requirements laid down in paragraph 5.4.3.6. if it lie(s) behind the transverse plane passing through the reference line and is/are located:

5.4.3.7.3.1. In the case of a single anchorage, within the area common to two dihedrals defined by the verticals passing through points J_1 and J_2 as defined in paragraph 5.4.3.1. and whose horizontal sections are shown in figure 2 of annex 3 of this Regulation;

5.4.3.7.3.2. In the case of two anchorages, within whichever of the above defined dihedrals is suitable, provided that each anchorage is not more than 50 mm distant from the symmetrically-located, mirror-image position of the other anchorage about plane P, as defined in paragraph 5.1.6. of the seat in question.

5.5. Dimensions of threaded anchorage holes

5.5.1. An anchorage shall have a threaded hole of 7/16 inch (20 UNF 2B).

5.5.2. If the vehicle is fitted by the manufacturer with safety-belts which are attached to all anchorages prescribed for the seat in question, these anchorages need not meet the requirement set out in paragraph 5.5.1., provided that they comply with the other provisions of this Regulation. In addition, the requirement set out in paragraph 5.5.1. shall not apply to additional anchorages which meet the requirement set out in paragraph 5.4.3.7.3.

5.5.3. It shall be possible to remove the safety-belt without damaging the anchorage.

6. TESTS

6.1. General tests for seat belt anchorages

6.1.1. Subject to application of the provisions of paragraph 6.2., and at the request of the manufacturer;

6.1.1.1. the tests may be carried out either on a vehicle structure or on a completely finished vehicle;

6.1.1.2. The tests may be restricted to the anchorages relating to only one seat or one group of seats on the condition that:

(a) the anchorages concerned have the same structural characteristics as the anchorages relating to the other seats or group of seats; and

(b) where such anchorages are fitted totally or partially on the seat or group of seats, the structural characteristics of the seat or group of seats are the same as those for the other seats or groups of seats.

- 6.1.1.3. windows and doors may be fitted or not and closed or not;
- 6.1.1.4. any fitting normally provided and likely to contribute to the rigidity of the vehicle structure may be fitted.
- 6.1.2. The seats shall be fitted and placed in the position for driving or use chosen by the technical service responsible for conducting approval tests to give the most adverse conditions with respect to the strength of the system. The position of the seats shall be stated in the report. The seat-back shall, if its inclination is adjustable, be locked as specified by the manufacturer or, in the absence of any such specification, in a position corresponding to an effective seat-back angle as close as possible to 25° for vehicles of categories M₁ and N₁ and to 15° for vehicles of all other categories.
- 6.2. Securing the vehicle for seat belt anchorages tests and for ISOFIX anchorages tests
- 6.2.1. The method used to secure the vehicle during the test shall not be such as to strengthen the seat belt anchorages or the ISOFIX anchorages and their anchorage area or to lessen the normal deformation of the structure.
- 6.2.2. A securing device shall be regarded as satisfactory if it produces no effect on an area extending over the whole width of the structure and if the vehicle or the structure is blocked or fixed in front at a distance of not less than 500 mm from the anchorage to be tested and is held or fixed at the rear not less than 300 mm from that anchorage.
- 6.2.3. It is recommended that the structure should rest on supports arranged approximately in line with the axes of the wheels or, if that is not possible, in line with the points of attachment of the suspension.
- 6.2.4. If a securing method other than that prescribed in paragraphs 6.2.1. to 6.2.3. of this Regulation is used, evidence must be furnished that it is equivalent.
- 6.3. General test requirements for seat belt anchorages
- 6.3.1. All the belt anchorages of the same group of seats shall be tested simultaneously. However, if there is a risk that non-symmetrical loading of the seats and/or anchorages may lead to failures, an additional test may be carried out with non-symmetrical loading.
- 6.3.2. The tractive force shall be applied in a direction corresponding to the seating position at an angle of 10 degrees ± 5° above the horizontal in a plane parallel to the median longitudinal plane of the vehicle.

A preload of 10 per cent with a tolerance of ± 30 per cent of the target load shall be applied; the load shall be increased to 100 per cent of the relevant target load.

- 6.3.3. Full application of the load shall be achieved as rapidly as possible, and within a maximum load application time of 60 seconds.

However, the manufacturer may request the application of the load to be achieved within 4 seconds.

The belt anchorages must withstand the specified load for not less than 0.2 second.

- 6.3.4. Traction devices to be used in the tests described in paragraph 6.4. below are shown in annex 5. The devices shown in annex 5, figure 1 are placed onto the seat cushion and then, when possible, pushed back into the seat back while the belt strap is pulled tight around it. The device shown in annex 5, figure 2 is placed in position, the belt strap is fitted over the device and pulled tight. No preload beyond the minimum necessary for correct positioning of the test device shall be introduced to safety-belt anchorages during this operation.

The traction device of either 254 mm or 406 mm used at each seating position shall be such that its width is as close as possible to the distance between the lower anchorages.

The positioning of the traction device shall avoid any mutual influences during the pull test which adversely affects the load and load distribution.

- 6.3.5. The belt anchorages for seats for which upper belt anchorages are provided shall be tested under the following conditions:

- 6.3.5.1. Front outboard seats:

The belt anchorages shall be submitted to the test prescribed in paragraph 6.4.1. in which the loads are transmitted to them by means of a device reproducing the geometry of a three-point belt equipped with a retractor having a pulley or strap guide at the upper belt anchorage. In addition, if the number of anchorages is more than that prescribed in paragraph 5.3., these anchorages shall be subjected to the test specified in paragraph 6.4.5., in which the loads shall be transmitted to the anchorages by means of a device reproducing the geometry of the type of safety-belt intended to be attached to them.

- 6.3.5.1.1. In the case where the retractor is not attached to the required outboard lower belt anchorage or in the case where the retractor is attached to the upper belt anchorage, the lower belt anchorages shall also be submitted to the test prescribed in paragraph 6.4.3.

- 6.3.5.1.2. In the above case the tests prescribed in paragraphs 6.4.1. and 6.4.3. can be performed on two different structures if the manufacturer so requests.
- 6.3.5.2. Rear outboard seats and all centre seats:
- The belt anchorages shall be subjected to the test prescribed in paragraph 6.4.2. in which the loads are transmitted to them by means of a device reproducing the geometry of a three-point safety-belt without a retractor, and to the test prescribed in paragraph 6.4.3., in which the loads are transmitted to the two lower belt anchorages by means of a device reproducing the geometry of a lap belt. The two tests can be performed on two different structures if the manufacturer so requests.
- 6.3.5.3. When a manufacturer supplies his vehicle with safety-belts, the corresponding belt anchorages may, at the request of the manufacturer, be submitted only to a test in which the loads are transmitted to them by means of a device reproducing the geometry of the type of belts to be attached to these anchorages.
- 6.3.6. If no upper belt anchorages are provided for the outboard seats and the centre seats, the lower belt anchorages shall be submitted to the test prescribed in paragraph 6.4.3., in which the loads are transmitted to these anchorages by means of a device reproducing the geometry of a lap belt.
- 6.3.7. If the vehicle is designed to accept other devices which do not enable the straps to be directly attached to belt anchorages without intervening sheaves, etc. or which require belt anchorages supplementary to those mentioned in paragraph 5.3., the safety-belt or an arrangement of wires, sheaves, etc. representing the equipment of the safety-belt, shall be attached by such a device to the belt anchorages in the vehicle and the belt anchorages shall be subjected to the tests prescribed in paragraph 6.4., as appropriate.
- 6.3.8. A test method other than those prescribed in paragraph 6.3. may be used, but evidence must be furnished that it is equivalent.
- 6.4. Particular test requirements for seat belt anchorages
- 6.4.1. Test in configuration of a three-point belt incorporating a retractor having a pulley or strap guide at the upper belt anchorage
- 6.4.1.1. A special pulley or guide for the wire or strap appropriate to transmit the load from the traction device, or the pulley or strap guide supplied by the manufacturer shall be fitted to the upper belt anchorage.
- 6.4.1.2. A test load of $1350 \text{ daN} \pm 20 \text{ daN}$ shall be applied to a traction device (see annex 5, figure 2) attached to the belt anchorages of the same belt, by means of a device reproducing the geometry of the upper torso strap of such a safety-belt. In the case

of vehicles of categories other than M_1 and N_1 , the test load shall be 675 ± 20 daN, except that for M_3 and N_3 vehicles the test load shall be 450 ± 20 daN.

6.4.1.3. At the same time a tractive force of $1350 \text{ daN} \pm 20 \text{ daN}$ shall be applied to a traction device (see annex 5, figure 1) attached to the two lower belt anchorages. In the case of vehicles of categories other than M_1 and N_1 , the test load shall be 675 ± 20 daN, except that for M_3 and N_3 vehicles the test load shall be 450 ± 20 daN.

6.4.2. Test in configuration of a three-point belt without retractor or with a retractor at the upper belt anchorage

6.4.2.1. A test load of $1350 \text{ daN} \pm 20 \text{ daN}$ shall be applied to a traction device (see annex 5, figure 2) attached to the upper belt anchorage and to the opposite lower belt anchorage of the same belt using, if supplied by the manufacturer, a retractor fixed at the upper belt anchorage. In the case of vehicles of categories other than M_1 and N_1 , the test load shall be 675 ± 20 daN, except that for M_3 and N_3 vehicles the test load shall be 450 ± 20 daN.

6.4.2.2. At the same time a tractive force of $1350 \text{ daN} \pm 20 \text{ daN}$ shall be applied to a traction device (see annex 5, figure 1) attached to the lower belt anchorages. In the case of vehicles of categories other than M_1 and N_1 , the test load shall be 675 ± 20 daN, except that for M_3 and N_3 vehicles the test load shall be 450 ± 20 daN.

6.4.3. Test in configuration of a lap belt

A test load of $2225 \text{ daN} \pm 20 \text{ daN}$ shall be applied to a traction device (see annex 5, figure 1) attached to the two lower belt anchorages. In the case of vehicles of categories other than M_1 and N_1 , the test load shall be 1110 ± 20 daN, except that for M_3 and N_3 vehicles the test load shall be 740 ± 20 daN.

6.4.4. Test for belt anchorages located wholly within the seat structure or dispersed between the vehicle structure and the seat structure

6.4.4.1. The test specified in paragraphs 6.4.1., 6.4.2. and 6.4.3. above shall be performed, as appropriate, at the same time superimposing for each seat and for each group of seats a force as stated below.

6.4.4.2. The loads indicated in paragraphs 6.4.1., 6.4.2. and 6.4.3 above shall be supplemented by a force equal to 20 times the mass of the complete seat. The inertia load shall be applied to the seat or to the relevant parts of the seat corresponding to the physical effect of the mass of the seat in question to the seat

anchorage. The determination of the additional applied load or loads and the load distribution shall be made by the manufacturer and agreed by the Technical Service.

In the case of vehicles in categories M₂ and N₂, this force must be equal to 10 times the mass of the complete seat; for categories M₃ and N₃ it shall be equal to 6.6 times the mass of the complete seat.

6.4.5. Test in configuration of a special-type belt

6.4.5.1. A test load of 1350 ± 20 daN shall be applied to a traction device (see annex 5, figure 2) attached to the belt anchorages of such a safety-belt by means of a device reproducing the geometry of the upper torso strap or straps.

6.4.5.2. At the same time, a tractive force of 1350 ± 20 daN shall be applied to a traction device (see annex 5, figure 3) attached to the two lower belt anchorages.

6.4.5.3. In the case of vehicles of categories other than M₁ and N₁, this test load shall be 675 ± 20 daN, except that for M₃ and N₃ vehicles the test load shall be 450 ± 20 daN.

6.4.6. Test in the case of rearward-facing seats

6.4.6.1. The anchorage points shall be tested according to the forces prescribed in paragraphs 6.4.1., 6.4.2. or 6.4.3., as appropriate. In each case the test load shall correspond to the load prescribed for M₃ or N₃ vehicles.

6.4.6.2. The test load shall be directed forward in relation to the seating position in question, corresponding to the procedure prescribed in paragraph 6.3.

6.5. In the case of a group of seats as described in paragraph 1. of annex 7, the dynamic test of annex 7 can be performed, at the option of the car manufacturer, as an alternative to the static test prescribed in paragraphs 6.3. and 6.4.

6.6. Static test requirements.

6.6.1. The strength of the ISOFIX anchorage systems shall be tested applying the forces, as prescribed in paragraph 6.6.4.3., to the static force application device (SFAD) with ISOFIX attachments well engaged.

In case of ISOFIX top tether anchorage an additional test shall be performed as prescribed in paragraph 6.6.4.4.

All the ISOFIX positions of a same seat row, which can be used simultaneously, shall be tested simultaneously.

6.6.2. The test may be carried out either on a completely finished vehicle or on sufficient parts of the vehicle so as to be representative of the strength and rigidity of the vehicle structure.

Windows and doors may be fitted or not and closed or not.

Any fitting normally provided and likely to contribute to the vehicle structure may be fitted.

The test may be restricted to the ISOFIX position relating to only one seat or group of seats on the condition that:

- (a) The ISOFIX position concerned have the same structural characteristics as the ISOFIX position relating to the other seats or group of seats and,
- (b) Where such ISOFIX positions are fitted totally or partially on the seat or group of seats, the structural characteristics of the seat or group of seats are the same as those for the other seats or groups of seats.

6.6.3. If the seats and head restraint are adjustable, they shall be tested in the position defined by the technical service within the limited range prescribed by the car manufacturer as provided in appendix 3 of annex 17 of Regulation No. 16.

6.6.4. Forces, directions and excursion limits.

6.6.4.1. A force of $135 \text{ N} \pm 15 \text{ N}$ shall be applied to the centre of the lower front crossbar of the SFAD in order to adjust the fore-aft position of the SFAD rearward extension to remove any slack or tension between the SFAD and its support.

6.6.4.2. Forces shall be applied to the static force application device (SFAD) in forward and oblique directions according to table 1.

Table 1: Directions of test forces

Forward	$0^\circ \pm 5^\circ$	$8 \text{ kN} \pm 0.25 \text{ kN}$
Oblique	$75^\circ \pm 5^\circ$ (to both sides of straight forward, or if any worst case side, or if both side are symmetric, only one side)	$5 \text{ kN} \pm 0.25 \text{ kN}$

Each of these tests may be performed on different structures if the manufacturer so requests.

Forces in the forward direction shall be applied with an initial force application angle of $10 \pm 5^\circ$ above the horizontal. Oblique forces shall be applied horizontally $0^\circ \pm 5^\circ$. A pre-load force of $500 \text{ N} \pm 25 \text{ N}$ shall be applied at the prescribed loading

point X indicated in figure 2 annex 9. Full application of the force shall be achieved within a period of 2 s or less. The force shall be maintained for a minimum period of 0.2 s.

All measurements shall be made according to ISO 6487 with CFC of 60 Hz or any equivalent method.

6.6.4.3. Tests of ISOFIX anchorages system only:

6.6.4.3.1. Forward direction force test:

Horizontal longitudinal excursion (after pre-load) of point X of SFAD during application of the $8 \text{ kN} \pm 0.25 \text{ kN}$ force shall be limited to 125 mm and permanent deformation including partial rupture or breakage of any ISOFIX low anchorage or surrounding area shall not constitute failure if the required force is sustained for the specified time.

6.6.4.3.2. Oblique direction force test:

Excursion in the direction of the force (after pre-load) of point X of SFAD during application of the $5 \text{ kN} \pm 0.25 \text{ kN}$ force shall be limited to 125 mm and permanent deformation including partial rupture or breakage of any ISOFIX low anchorage or surrounding area shall not constitute failure if the required force is sustained for the specified time.

6.6.4.4. Test of ISOFIX anchorages systems and ISOFIX top tether anchorage:

A tension pre-load of $50 \text{ N} \pm 5 \text{ N}$ must be applied between the SFAD and the top-tether anchorage. Horizontal excursion (after pre-load) of point X during application of the $8 \text{ kN} \pm 0.25 \text{ kN}$ force shall be limited to 125 mm and permanent deformation including partial rupture or breakage of any ISOFIX low anchorage and top tether anchorage, or surrounding area shall not constitute failure if the required force is sustained for the specified time.

Table 2: Excursions limits

Force direction	Maximum excursion of point X of SFAD
Forward	125 mm longitudinal
Oblique	125 mm force direction

page 30

6.6.5. Additional forces.

6.6.5.1. Seat inertia forces.

For the installation position where the load is transferred into a vehicle seat assembly, and not directly into the vehicle structure, a test shall be carried out to ensure that the strength of the vehicle seat anchorages to the vehicle structure is sufficient. In this test, a force equal to 20 times the mass of the relevant parts of the seat assembly shall be applied horizontally and longitudinally in a forward direction to the seat or the relevant part of the seat assembly corresponding to the physical effect of the mass of the seat in question to the seat anchorages. The determination of the additional applied load or loads and the load distribution shall be made by the manufacturer and agreed by the Technical Service.

At the request of the manufacturer, the additional load can be applied at the X point of SFAD during the static tests described above.

If the top tether anchorage is integrated to the vehicle seat, this test shall be performed with the ISOFIX top tether strap.

No breakage shall occur and excursion requirements given in the table 2 have to be fulfilled.

NOTE: This test does not have to be performed in case of any anchorage of the vehicle safety-belt system is integrated to the vehicle seat structure, and the vehicle seat is already tested and approved to meet the anchorage load tests required by this Regulation for adult passenger restraint.

7. INSPECTION DURING AND AFTER STATIC TESTS FOR SAFETY-BELT ANCHORAGES

7.1. All the anchorages shall be capable of withstanding the test prescribed in paragraphs 6.3. and 6.4. Permanent deformation, including partial rupture or breakage of any anchorage or surrounding area, shall not constitute failure if the required force is sustained for the specified time. During the test, the minimum spacings for the effective lower belt anchorages specified in paragraph 5.4.2.5. and the requirements of paragraph 5.4.3.6. for effective upper belt anchorages shall be respected.

7.1.1. For vehicles of category M₁ of a total permissible mass not exceeding 2.5 tonnes, if the upper safety-belt anchorage is attached to the seat structure, the effective upper safety-belt anchorage shall not be displaced during the test forward of a transverse plane passing through the R point and point C of the seat in question (see figure 1 of annex 3 to this Regulation)

For vehicles other than mentioned above, the effective upper safety-belt anchorage shall not be displaced during the test forward of a transverse plane inclined 10° in forward direction and passing through the R point of the seat.

The maximum displacement of the effective upper anchorage point shall be measured during the test.

If the displacement of the effective upper anchorage point exceeds the above-mentioned limitation, the manufacturer shall demonstrate to the satisfaction of the technical service that there is no danger to the occupant. As an example, the test procedure according to Regulation No. 94 or a sled test with corresponding pulse may be carried out to demonstrate a sufficient survival space.

- 7.2. In vehicles where such devices are used, the displacement and locking devices enabling the occupants of all seats to leave the vehicle must still be operable by hand after the tractive force was removed.
- 7.3. After testing any damage to the anchorages and structures supporting load during tests shall be noted.
- 7.4. By derogation, the upper anchorages fitted to one or more seats of vehicles of category M₃ and those of category M₂ with a maximum mass exceeding 3.5 tonnes, which meet the requirements of Regulation No. 80, need not to comply with the requirements of paragraph 7.1. concerning compliance with paragraph 5.4.3.6.
8. **MODIFICATIONS AND EXTENSION OF APPROVAL OF THE VEHICLE TYPE**
 - 8.1. Every modification of the vehicle type shall be notified to the administrative department which approved the vehicle type. The department may then either:
 - 8.1.1. consider that the modifications made are unlikely to have an appreciable adverse effect and that in any case the vehicle still complies with the requirements; or
 - 8.1.2. require a further test report from the technical service responsible for conducting the tests.
 - 8.2. Confirmation or refusal of approval, specifying the alterations, shall be communicated by the procedure specified in paragraph 4.3. above to the Parties to the Agreement which apply this Regulation.
 - 8.3. The competent authority issuing the extension of approval shall assign a series number for such an extension and inform thereof the other Parties to the 1958 Agreement applying this Regulation by means of a communication form conforming to the model in annex 1 to this Regulation.

9. CONFORMITY OF PRODUCTION

The conformity of production procedures shall comply with those set out in the Agreement, appendix 2 (E/ECE/324-E/ECE/TRANS/505/Rev.2), with the following requirements:

- 9.1. Every vehicle bearing an approval mark as prescribed under this Regulation shall conform to the vehicle type approved with regard to details affecting the characteristics of the safety-belt anchorages and the ISOFIX anchorages system and ISOFIX top tether anchorage.
- 9.2. In order to verify conformity as prescribed in paragraph 9.1. above, a sufficient number of serially-produced vehicles bearing the approval mark required by this Regulation shall be subjected to random checks.
- 9.3. As a general rule the checks as aforesaid shall be confined to the taking of measurements. However, if necessary, the vehicles shall be subjected to some of the tests described in paragraph 6. above, selected by the technical service conducting approval tests.

10. PENALTIES FOR NON-CONFORMITY OF PRODUCTION

- 10.1. The approval granted in respect of a vehicle type pursuant to this Regulation may be withdrawn if the requirement laid down in paragraph 9.1. above is not complied with or if its safety-belt anchorages or the ISOFIX anchorages system and ISOFIX top tether anchorage failed to pass the checks prescribed in paragraph 9. above.
- 10.2. If a Contracting Party to the Agreement which applies this Regulation withdraws an approval it has previously granted, it shall forthwith so notify the other Contracting Parties applying this Regulation, by means of a communication form conforming to the model in annex 1 to this Regulation.

11. OPERATING INSTRUCTIONS

The national authorities may require the manufacturers of vehicles registered by them to state clearly in the instructions for operating the vehicle

- 11.1. where the anchorages are; and
- 11.2. for what types of belts the anchorages are intended (see annex 1, item 5).

12. PRODUCTION DEFINITELY DISCONTINUED

If the holder of the approval completely ceases to manufacture a type of safety-belt anchorages or a type of ISOFIX anchorages system and ISOFIX top tether anchorage approved in accordance with this Regulation, he shall so inform the authority which granted the approval. Upon receiving the relevant communication that authority shall inform thereof the other Parties to the 1958 Agreement, which apply this Regulation by means of a communication form conforming to the model in annex 1 to this Regulation.

13. NAMES AND ADDRESSES OF TECHNICAL SERVICES RESPONSIBLE FOR CONDUCTING APPROVAL TESTS, AND OF ADMINISTRATIVE DEPARTMENTS

The Parties to the 1958 Agreement applying this Regulation shall communicate to the United Nations secretariat the names and addresses of the technical services responsible for conducting approval tests and of the administrative departments which grant approval and to which forms certifying approval or extension, or refusal or extension or withdrawal of approval, issued in other countries, are to be sent.

14. TRANSITIONAL PROVISIONS

14.1. As from the official date of entry into force of the 06 series of amendments, no Contracting Party applying this Regulation shall refuse to grant ECE approvals under this Regulation as amended by the 06 series of amendments.

14.2. As from 2 years after the enter into force of the 06 series of amendments to this Regulation, Contracting parties applying this Regulation shall grant ECE type approvals only if the requirements of this Regulation, as amended by the 06 series of amendments, are satisfied.

14.3. As from 7 years after the enter into force of the 06 series of amendments to this Regulation, Contracting parties applying this Regulation may refuse to recognize approvals which were not granted in accordance with the 06 series of amendments to this Regulation.

14.4. For vehicles not affected by paragraph 7.1.1. above, approvals granted according to the 04 series of amendments to this Regulation shall remain valid.

14.5. For vehicles not affected by Supplement 4 to the 05 series of amendments to this Regulation the existing approvals shall remain valid, if they had been granted in compliance with the 05 series of amendments, up to its Supplement 3.

page 34

- 14.6. As from the official date of entry into force of Supplement 5 to the 05 series of amendments, no Contracting Party applying this Regulation shall refuse to grant ECE approvals under this Regulation as modified by Supplement 5 to the 05 series of amendments."
- 14.7. For vehicles not affected by Supplement 5 to the 05 series of amendments to this Regulation the existing approvals shall remain valid, if they had been granted in compliance with the 05 series of amendments, up to its Supplement 3.
- 14.8. As from 20 February 2005 for vehicles of category M1, Contracting Parties applying this Regulation shall grant ECE approvals only if the requirements of this Regulation, as amended by Supplement 5 to the 05 series of amendments, are satisfied.
- 14.9. As from 20 February 2007 for vehicles of category M1, Contracting Parties applying this Regulation may refuse to recognize approvals which were not granted in accordance with Supplement 5 to the 05 series of amendments to this Regulation.
- 14.10. As from 16 July 2006 for vehicles of category N, Contracting Parties applying this Regulation shall grant approval only if the vehicle type satisfies the requirements of this Regulation as amended by the Supplement 5 to the 05 series of amendments.
- 14.11. As from 16 July 2008 for vehicles of category N, Contracting Parties applying this Regulation may refuse to recognize approvals not granted in accordance with Supplement 5 to the 05 series of amendments to this Regulation.

Annex 1

COMMUNICATION

(maximum format: A4 (210 x 297 mm))



issued by: Name of administration

.....
.....
.....

concerning: 2/

- APPROVAL GRANTED
- APPROVAL EXTENDED
- APPROVAL REFUSED
- APPROVAL WITHDRAWN
- PRODUCTION DEFINITELY DISCONTINUED

of a vehicle type with regard to safety-belt anchorages and ISOFIX anchorages systems and ISOFIX top tether anchorage if any pursuant to Regulation No. 14

Approval No.

Extension No.

1. Trade name or mark of the power-driven vehicle
2. Type of vehicle
3. Manufacturer's name and address
4. If applicable, name and address of manufacturer's representative
.....

5. Designation of the type of belts and retractors authorized for fitting to the anchorages with which the vehicle is equipped:

		Anchorage on */	
		vehicle structure	seat structure
Front	Right-hand seat	{ lower anchorages { outboard { upper anchorage { inboard	
	Middle seat	{ lower anchorages { right { upper anchorage { left	
	Left-hand seat	{ lower anchorages { outboard { upper anchorage { inboard	
Rear	Right-hand seat	{ lower anchorages { outboard { upper anchorage { inboard	
	Middle seat	{ lower anchorages { right { upper anchorage { left	
	Left-hand seat	{ lower anchorages { outboard { upper anchorage { inboard	

*/ Insert in the actual position the following letter(s):

- "A" for a three-point belt,
- "B" for lap belts,
- "S" for special-type belts; in this case the type shall be stated under "Remarks",
- "Ar", "Br" or "Sr" for belts with retractors,
- "Ae", "Be" or "Se" for belts with an energy absorption device,
- "Are", "Bre" or "Sre" for belts with retractors and energy-absorption devices on at least one anchorage.

Remarks:

6. Description of seats 3/

7. Description of the adjustment, displacement and locking systems either of the seat or of its parts: 3/
8. Description of seat anchorage: 3/
9. Description of particular type of safety-belt required in the case of an anchorage located in the seat structure or incorporating an energy-dissipating device:
10. Vehicle submitted for approval on:
11. Technical service responsible for conducting approval tests:
12. Date of report issued by that service:
13. Number of report issued by that service:
14. Approval granted/extended/refused/withdrawn 2/
15. Position of approval mark on vehicle:
16. Place:
17. Date:
18. Signature:
9. The following documents, filed with the administration service which has granted approval and available on request are annexed to this communication:
 - drawings, diagrams and plans of the belt anchorages, ISOFIX anchorages systems, of the top tether anchorages if any, and of the vehicle structure;
 - photographs of the belt anchorages, of the ISOFIX anchorages systems, of the top tether if any, and of the vehicle structure;
 - drawings, diagrams and plans of the seats, of their anchorage on the vehicle, of the adjustment and displacement systems of the seats and of their parts and of their locking devices; 3/
 - photographs of the seats, of their anchorage, of the adjustment and displacement systems of the seats and of their parts, and of their locking devices. 3/

1/ Distinguishing number of the country, which has granted/extended/refused/withdrawn approval (see approval provisions in the Regulation).

2/ Strike out what does not apply.

3/ Only if the anchorage is affixed on the seat or if the seat supports the belt strap.

Annex 2

ARRANGEMENTS OF THE APPROVAL MARK

Model A

(see paragraph 4.4. of this Regulation)



a = 8 mm min.

The above approval mark affixed to a vehicle shows that the vehicle type concerned has, with regard to safety-belt anchorages, been approved in the Netherlands (E 4), pursuant to Regulation No. 14, under the number 062439. The first two digits of the approval number indicate that Regulation No. 14 already included the 06 series of amendments when the approval was given.

Model B

(see paragraph 4.5. of this Regulation)

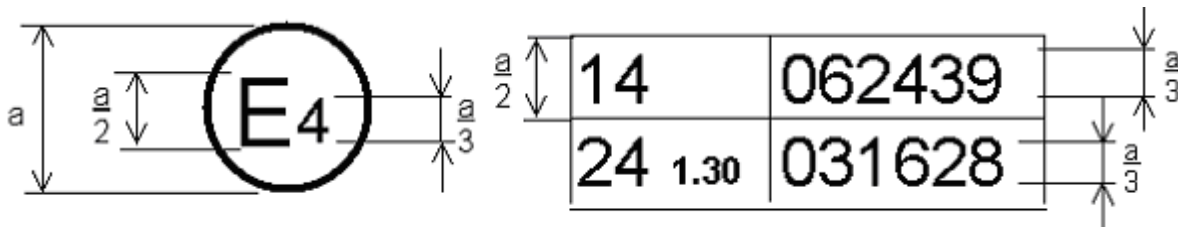

a = 8 mm min.

The above approval mark affixed to a vehicle shows that the vehicle type concerned has been approved in the Netherlands (E 4) pursuant to Regulations Nos. 14 and 24. */ (In the case of the latter Regulation the corrected absorption co-efficient is 1.30 m⁻¹). The approval numbers indicate that on the dates on which these approvals were granted, Regulation No. 14 included the 06 series of amendments and Regulation No. 24 was in its 03 series of amendments.

*/ The second number is given merely as an example.

Annex 3

LOCATION OF EFFECTIVE BELT ANCHORAGES

Figure 1: Areas of location of effective belt anchorages
(The drawing shows one example, where the upper anchorage is fixed to the vehicle body side panel)

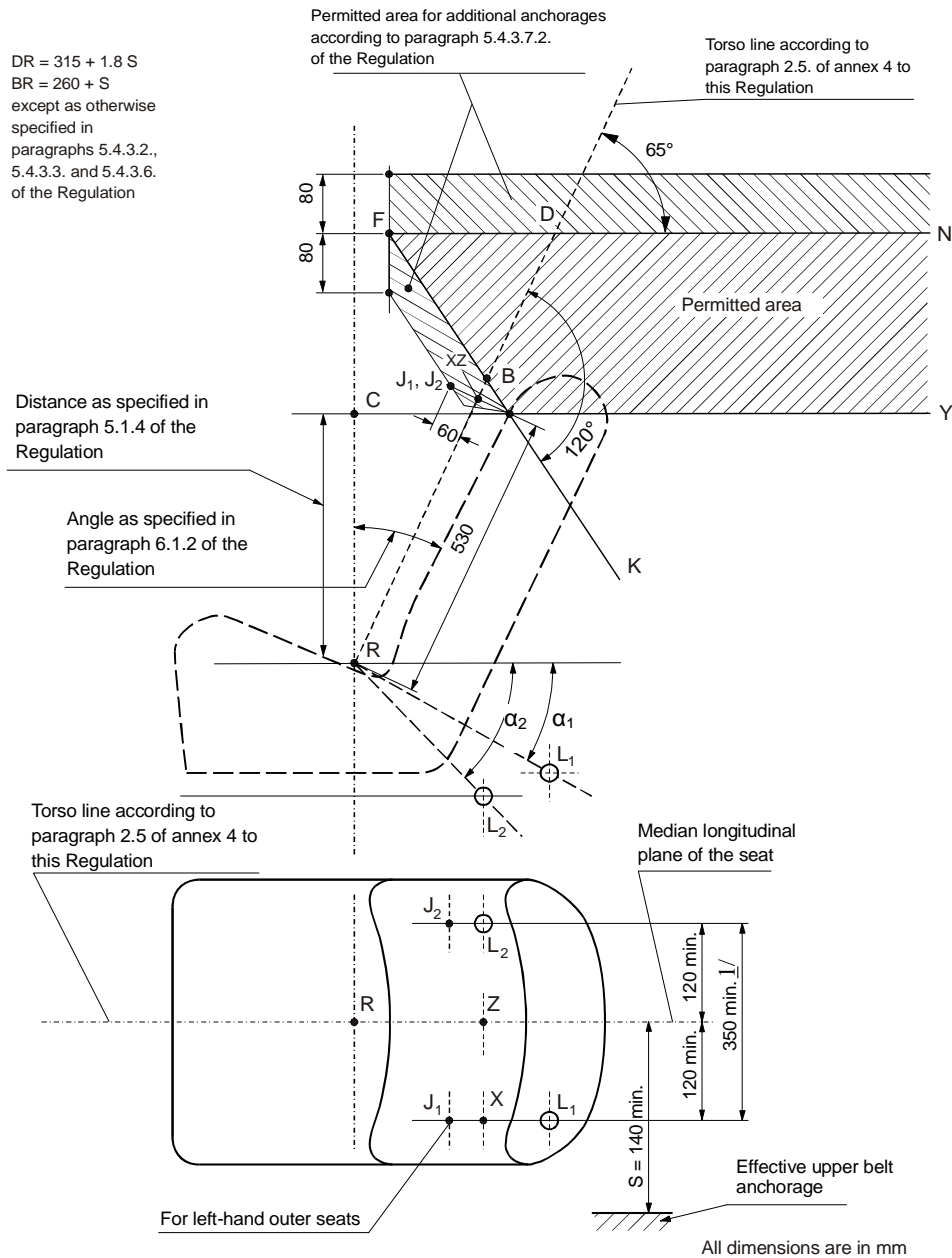

1/ 240 mm minimum for the central rear seating positions of M₁ and N₁ categories of vehicles

Figure 2: Effective upper anchorages
conforming to paragraph 5.4.3.7.3. of the Regulation

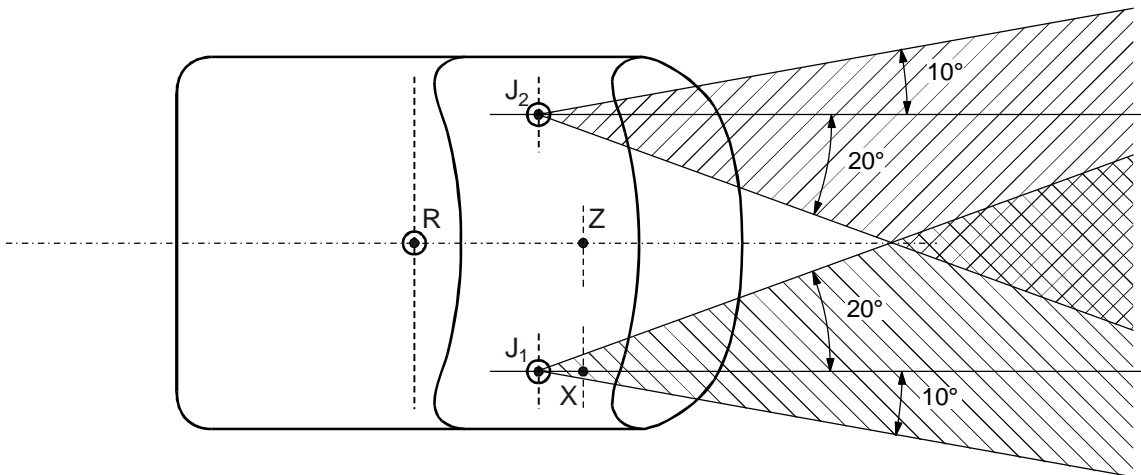

Annex 4

PROCEDURE FOR DETERMINING THE "H" POINT AND THE ACTUAL TORSO ANGLE
FOR SEATING POSITIONS IN MOTOR VEHICLES

1. PURPOSE

The procedure described in this annex is used to establish the "H" point location and the actual torso angle for one or several seating positions in a motor vehicle and to verify the relationship of measured data to design specifications given by the vehicle manufacturer. 1/

2. DEFINITIONS

For the purposes of this annex:

- 2.1. "Reference data" means one or several of the following characteristics of a seating position:
- 2.1.1. the "H" point and the "R" point and their relationship,
- 2.1.2. the actual torso angle and the design torso angle and their relationship.
- 2.2. "Three-dimensional 'H' point machine" (3-D H machine) means the device used for the determination of "H" points and actual torso angles. This device is described in appendix 1 to this annex;
- 2.3. "'H' point" means the pivot centre of the torso and the thigh of the 3-D H machine installed in the vehicle seat in accordance with paragraph 4 below. The "H" point is located in the centre of the centreline of the device which is between the "H" point sight buttons on either side of the 3-D H machine. The "H" point corresponds theoretically to the "R" point (for tolerances see paragraph 3.2.2. below). Once determined in accordance with the procedure described in paragraph 4, the "H" point is considered fixed in relation to the seat-cushion structure and to move with it when the seat is adjusted;
- 2.4. "'R' point" or "seating reference point" means a design point defined by the vehicle manufacturer for each seating position and established with respect to the three-dimensional reference system;

1/ In any seating position other than front seats where the "H" point cannot be determined using the "Three-dimensional 'H' point machine" or procedures, the "R" point indicated by the manufacturer may be taken as a reference at the discretion of the competent authority.

page 42
Annex 4

- 2.5. "Torso-line" means the centreline of the probe of the 3-D H machine with the probe in the fully rearward position;
- 2.6. "Actual torso angle" means the angle measured between a vertical line through the "H" point and the torso line using the back angle quadrant on the 3-D H machine. The actual torso angle corresponds theoretically to the design torso angle (for tolerances see paragraph 3.2.2. below);
- 2.7. "Design torso angle" means the angle measures between a vertical line through the "R" point and the torso line in a position which corresponds to the design position of the seat-back established by the vehicle manufacturer;
- 2.8. "Centreplane of occupant" (C/LO) means the median plane of the 3-D H machine positioned in each designated seating position; it is represented by the co-ordinate of the "H" point on the "Y" axis. For individual seats, the centreplane of the seat coincides with the centreplane of the occupant. For other seats, the centreplane of the occupant is specified by the manufacturer;
- 2.9. "Three-dimensional reference system" means a system as described in appendix 2 to this annex;
- 2.10. "Fiducial marks" are physical points (holes, surfaces, marks or indentations) on the vehicle body as defined by the manufacturer;
- 2.11. "Vehicle measuring attitude" means the position of the vehicle as defined by the co-ordinates of fiducial marks in the three-dimensional reference system.

3. REQUIREMENTS

3.1. Data presentation

For each seating position where reference data are required in order to demonstrate compliance with the provisions of the present Regulation, all or an appropriate selection of the following data shall be presented in the form indicated in appendix 3 to this annex:

- 3.1.1. the co-ordinates of the "R" point relative to the three-dimensional reference system;
- 3.1.2. the design torso angle;
- 3.1.3. all indications necessary to adjust the seat (if it is adjustable) to the measuring position set out in paragraph 4.3. below.

3.2. Relationship between measured data and design specifications

- 3.2.1. The co-ordinates of the "H" point and the value of the actual torso angle obtained by the procedure set out in paragraph 4. below shall be compared, respectively, with the co-ordinates of the "R" point and the value of the design torso angle indicated by the vehicle manufacturer.
- 3.2.2. The relative positions of the "R" point and the "H" point and the relationship between the design torso angle and the actual torso angle shall be considered satisfactory for the seating position in question if the "H" point, as defined by its co-ordinates, lies within a square of 50 mm side length with horizontal and vertical sides whose diagonals intersect at the "R" point, and if the actual torso angle is within 5° of the design torso angle.
- 3.2.3. If these conditions are met, the "R" point and the design torso angle, shall be used to demonstrate compliance with the provisions of this Regulation.
- 3.2.4. If the "H" point or the actual torso angle does not satisfy the requirements of paragraph 3.2.2. above, the "H" point and the actual torso angle shall be determined twice more (three times in all). If the results of two of these three operations satisfy the requirements, the conditions of paragraph 3.2.3. above shall apply.
- 3.2.5. If the results of at least two of the three operations described in paragraph 3.2.4. above do not satisfy the requirements of paragraph 3.2.2. above, or if the verification cannot take place because the vehicle manufacturer has failed to supply information regarding the position of the "R" point or regarding the design torso angle, the centroid of the three measured points or the average of the three measured angles shall be used and be regarded as applicable in all cases where the "R" point or the design torso angle is referred to in this Regulation.

4. **PROCEDURE FOR "H" POINT AND ACTUAL TORSO ANGLE DETERMINATION**

- 4.1. The vehicle shall be preconditioned at the manufacturer's discretion, at a temperature of 20 ± 10 °C to ensure that the seat material reached room temperature. If the seat to be checked has never been sat upon, a 70 to 80 kg person or device shall sit on the seat twice for one minute to flex the cushion and back. At the manufacturer's request, all seat assemblies shall remain unloaded for a minimum period of 30 min prior to installation of the 3-D H machine.
- 4.2. The vehicle shall be at the measuring attitude defined in paragraph 2.11. above.
- 4.3. The seat, if it is adjustable, shall be adjusted first to the rearmost normal driving or riding position, as indicated by the vehicle manufacturer, taking into consideration only the longitudinal adjustment of the seat, excluding seat travel used for purposes other

than normal driving or riding positions. Where other modes of seat adjustment exist (vertical, angular, seat-back, etc.) these will then be adjusted to the position specified by the vehicle manufacturer. For suspension seats, the vertical position shall be rigidly fixed corresponding to a normal driving position as specified by the manufacturer.

- 4.4. The area of the seating position contacted by the 3-D H machine shall be covered by a muslin cotton, of sufficient size and appropriate texture, described as a plain cotton fabric having 18.9 threads per cm² and weighing 0.228 kg/m² or knitted or non-woven fabric having equivalent characteristics. If test is run on a seat outside the vehicle, the floor on which the seat is placed shall have the same essential characteristics 2/ as the floor of the vehicle in which the seat is intended to be used.
- 4.5. Place the seat and back assembly of the 3-D H machine so that the centreplane of the occupant (C/LO) coincides with the centreplane of the 3-D H machine. At the manufacturer's request, the 3-D H machine may be moved inboard with respect to the C/LO if the 3-D H machine is located so far outboard that the seat edge will not permit levelling of the 3-D H machine.
- 4.6. Attach the foot and lower leg assemblies to the seat pan assembly, either individually or by using the T-bar and lower leg assembly. A line through the "H" point sight buttons shall be parallel to the ground and perpendicular to the longitudinal centreplane of the seat.
- 4.7. Adjust the feet and leg positions of the 3-D H machine as follows:
 - 4.7.1. Designated seating position: driver and outside front passenger
 - 4.7.1.1. Both feet and leg assemblies shall be moved forward in such a way that the feet take up natural positions on the floor, between the operating pedals if necessary. Where possible the left foot shall be located approximately the same distance to the left of the centreplane of the 3-D H machine as the right foot is to the right. The spirit level verifying the transverse orientation of the 3-D H machine is brought to the horizontal by readjustment of the seat pan if necessary, or by adjusting the leg and foot assemblies towards the rear. The line passing through the "H" point sight buttons shall be maintained perpendicular to the longitudinal centreplane of the seat.
 - 4.7.1.2. If the left leg cannot be kept parallel to the right leg and the left foot cannot be supported by the structure, move the left foot until it is supported. The alignment of the sight buttons shall be maintained.

2/ Tilt angle, height difference with a seat mounting, surface texture, etc.

4.7.2. Designated seating position: outboard rear

For rear seats or auxiliary seats, the legs are located as specified by the manufacturer. If the feet then rest on parts of the floor, which are at different levels, the foot which first comes into contact with the front seat shall serve as a reference and the other foot shall be so arranged that the spirit level giving the transverse orientation of the seat of the device indicates the horizontal.

4.7.3. Other designated seating positions:

The general procedure indicated in paragraph 4.7.1. above shall be followed except that the feet shall be placed as specified by the vehicle manufacturer.

4.8. Apply lower leg and thigh weights and level the 3-D H machine.

4.9. Tilt the back pan forward against the forward stop and draw the 3-D H machine away from the seat-back using the T-bar. Reposition the 3-D H machine on the seat by one of the following methods:

4.9.1. If the 3-D H machine tends to slide rearward, use the following procedure. Allow the 3-D H machine to slide rearward until a forward horizontal restraining load on the T-bar is no longer required i.e. until the seat pan contacts the seat-back. If necessary, reposition the lower leg.

4.9.2. If the 3-D H machine does not tend to slide rearward, use the following procedure. Slide the 3-D H machine rearwards by applying a horizontal rearward load to the T-bar until the seat pan contacts the seat-back (see figure 2 of appendix 1 to this annex).

4.10. Apply a 100 ± 10 N load to the back and pan assembly of the 3-D H machine at the intersection of the hip angle quadrant and the T-bar housing. The direction of load application shall be maintained along a line passing by the above intersection to a point just above the thigh bar housing (see figure 2 of appendix 1 to this annex). Then carefully return the back pan to the seat-back. Care must be exercised throughout the remainder of the procedure to prevent the 3-D H machine from sliding forward.

4.11. Install the right and left buttock weights and then, alternately, the eight torso weights. Maintain the 3-D H machine level.

4.12. Tilt the back pan forward to release the tension on the seat-back. Rock the 3-D H machine from side to side through 10° arc (5° to each side of the vertical centreplane) for three complete cycles to release any accumulated friction between the 3-D H machine and the seat.

During the rocking action, the T-bar of the 3-D H machine may tend to diverge from the specified horizontal and vertical alignment. The T-bar must therefore be restrained by applying an appropriate lateral load during the rocking motions. Care shall be exercised in holding the T-bar and rocking the 3-D H machine to ensure that no inadvertent exterior loads are applied in a vertical or fore and aft direction.

The feet of the 3-D H machine are not to be restrained or held during this step. If the feet change position, they should be allowed to remain in that attitude for the moment.

Carefully return the back pan to the seat-back and check the two spirit levels for zero position. If any movement of the feet has occurred during the rocking operation of the 3-D H machine, they must be repositioned as follows:

Alternately, lift each foot off the floor the minimum necessary amount until no additional foot movement is obtained. During this lifting, the feet are to be free to rotate; and no forward or lateral loads are to be applied. When each foot is placed back in the down position, the heel is to be in contact with the structure designed for this.

Check the lateral spirit level for zero position; if necessary, apply a lateral load to the top of the back pan sufficient to level the 3-D H machine's seat pan on the seat.

4.13. Holding the T-bar to prevent the 3-D H machine from sliding forward on the seat cushion, proceed as follows:

(a) return the back pan to the seat-back;

(b) alternately apply and release a horizontal rearward load, not to exceed 25 N, to the back angle bar at a height approximately at the centre of the torso weights until the hip angle quadrant indicates that a stable position has been reached after load release. Care shall be exercised to ensure that no exterior downward or lateral loads are applied to the 3-D H machine. If another level adjustment of the 3-D H machine is necessary, rotate the back pan forward, re-level, and repeat the procedure from paragraph 4.12.

4.14. Take all measurements:

4.14.1. The co-ordinates of the "H" point are measured with respect to the three-dimensional reference system.

4.14.2. The actual torso angle is read at the back angle quadrant of the 3-D H machine with the probe in its fully rearward position.

- 4.15. If a re-run of the installation of the 3-D H machine is desired, the seat assembly should remain unloaded for a minimum period of 30 min prior to the re-run. The 3-D H machine should not be left loaded on the seat assembly longer than the time required to perform the test.
- 4.16. If the seats in the same row can be regarded as similar (bench seat, identical seats, etc.) only one "H" point and one "actual torso angle" shall be determined for each row of seats, the 3-D H machine described in appendix 1 to this annex being seated in a place regarded as representative for the row. This place shall be:
- 4.16.1. in the case of the front row, the driver's seat;
- 4.16.2. in the case of the rear row or rows, an outer seat.

Annex 4 – Appendix 1

DESCRIPTION OF THE THREE DIMENSIONAL "H" POINT MACHINE */
(3-D H machine)

1. Back and seat pans

The back and seat pans are constructed of reinforced plastic and metal; they simulate the human torso and thigh and are mechanically hinged at the "H" point. A quadrant is fastened to the probe hinged at the "H" point to measure the actual torso angle. An adjustable thigh bar, attached to the seat pan, establishes the thigh centreline and serves as a baseline for the hip angle quadrant.

2. Body and leg elements

Lower leg segments are connected to the seat pan assembly at the T-bar joining the knees, which is a lateral extension of the adjustable thigh bar. Quadrants are incorporated in the lower leg segments to measure knee angles. Shoe and foot assemblies are calibrated to measure the foot angle. Two spirit levels orient the device in space. Body element weights are placed at the corresponding centres of gravity to provide seat penetration equivalent to a 76 kg male. All joints of the 3-D H machine should be checked for free movement without encountering noticeable friction.

*/ For details of the construction of the 3-D H machine refer to Society of Automobile Engineers (SAE), 400 Commonwealth Drive, Warrendale, Pennsylvania 15096, United States of America.

The machine corresponds to that described in ISO Standard 6549:1980.

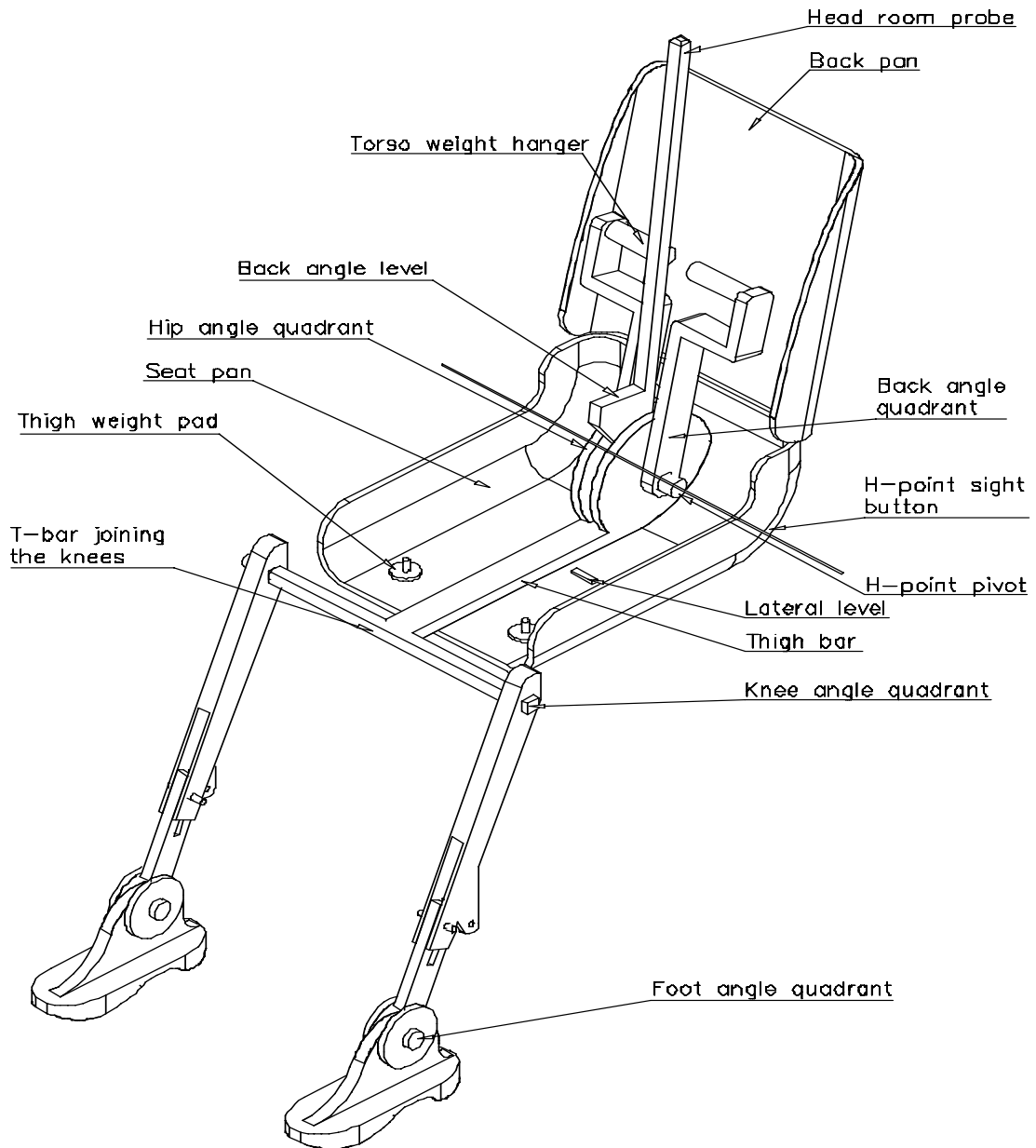

Figure 1: 3-D H machine elements designation

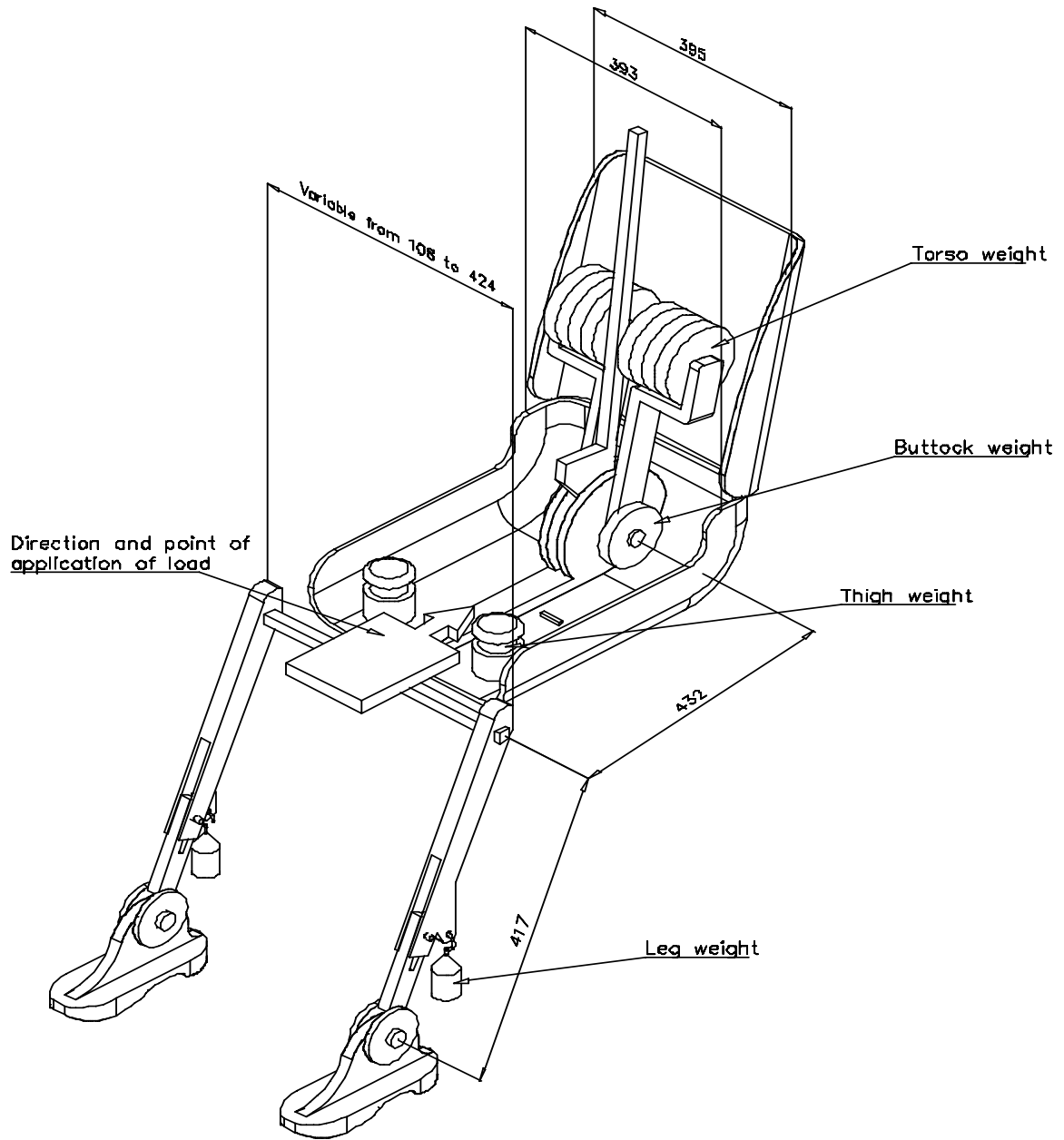

Figure 2: Dimensions of the 3-D H machine elements and load distribution

Annex 4 - Appendix 2

THREE-DIMENSIONAL REFERENCE SYSTEM

1. The three-dimensional reference system is defined by three orthogonal planes established by the vehicle manufacturer (see figure). */
2. The vehicle measuring attitude is established by positioning the vehicle on the supporting surface such that the co-ordinates of the fiducial marks correspond to the values indicated by the manufacturer.
3. The co-ordinates of the "R" point and the "H" point are established in relation to the fiducial marks defined by the vehicle manufacturer.

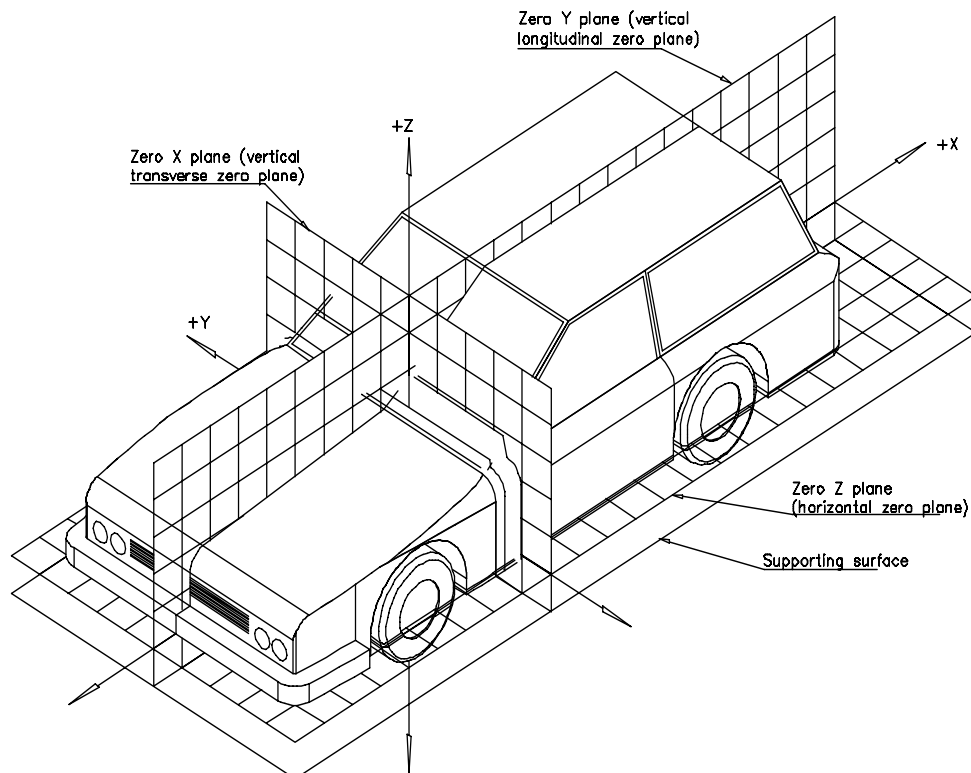

Figure: Three-dimensional reference system

*/ The reference system corresponds to standard ISO 4130:1978.

Annex 4 - Appendix 3

REFERENCE DATA CONCERNING SEATING POSITIONS

1. Coding of reference data

Reference data are listed consecutively for each seating position. Seating positions are identified by a two-digit code. The first digit is an Arabic numeral and designates the row of seats, counting from the front to the rear of the vehicle. The second digit is a capital letter, which designates the location of the seating position in a row, as viewed in the direction of forward motion of the vehicle; the following letters shall be used:

- L = left
- C = centre
- R = right

2. Description of vehicle measuring attitude

2.1. Co-ordinates of fiducial marks

- X
- Y
- Z

3. List of reference data

3.1. Seating position:

3.1.1. Co-ordinates of "R" point

- X
- Y
- Z

3.1.2. Design torso angle:

3.1.3. Specifications for seat adjustment */

- horizontal:
- vertical:
- angular:
- torso angle:

Note: List reference data for further seating positions under 3.2., 3.3., etc.

*/ Strike out what does not apply.

Annex 5

TRACTION DEVICE

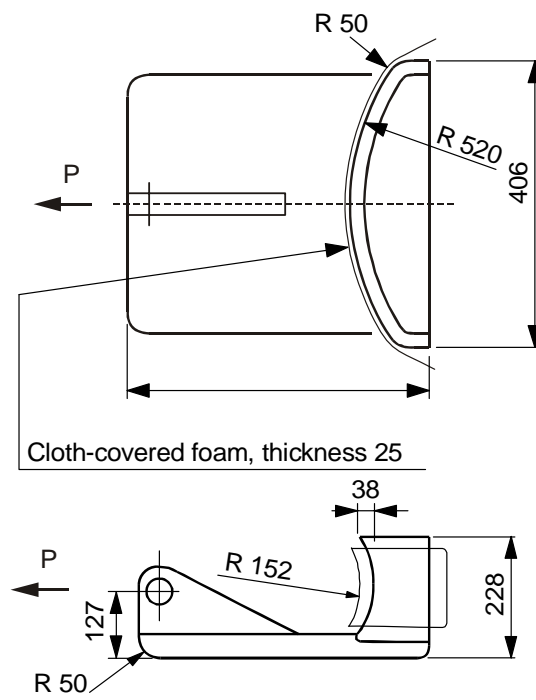

Figure 1

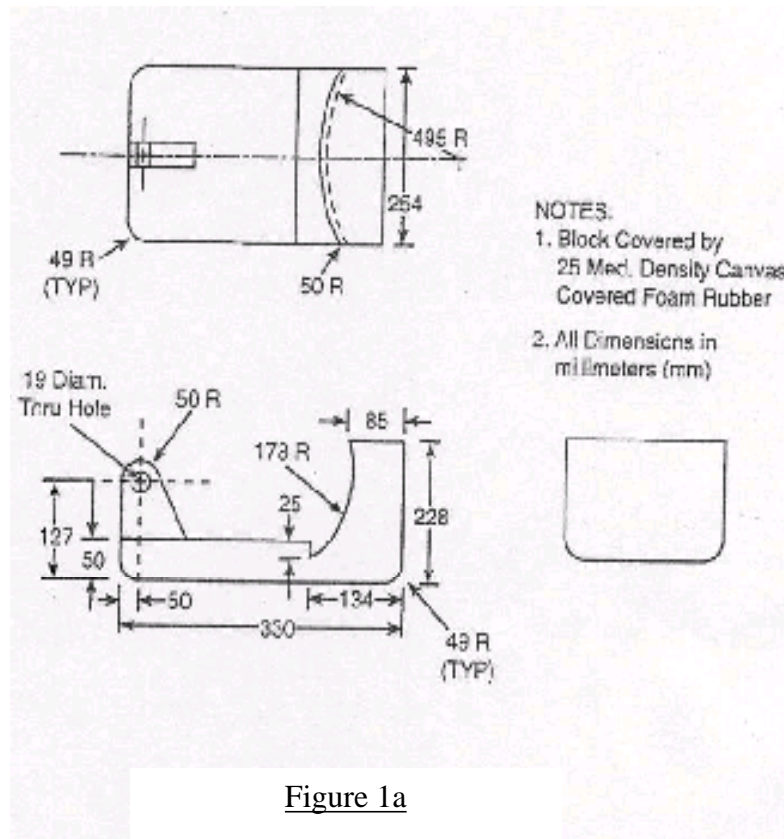
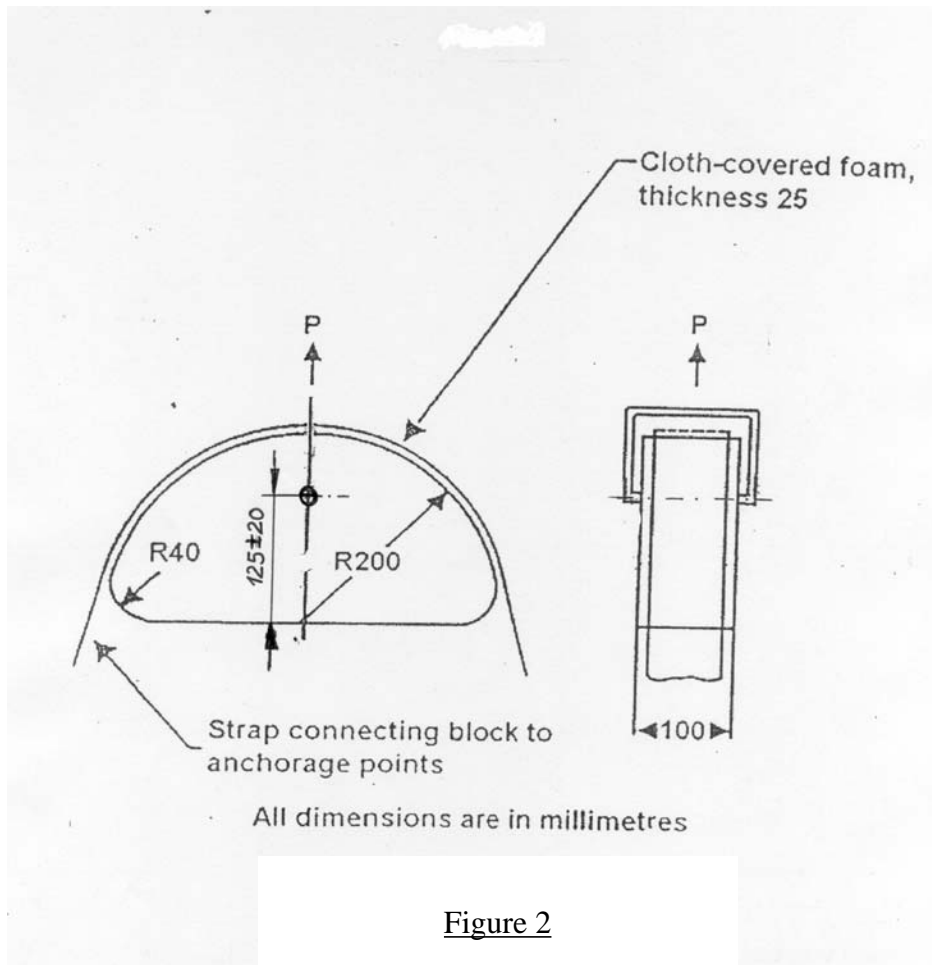
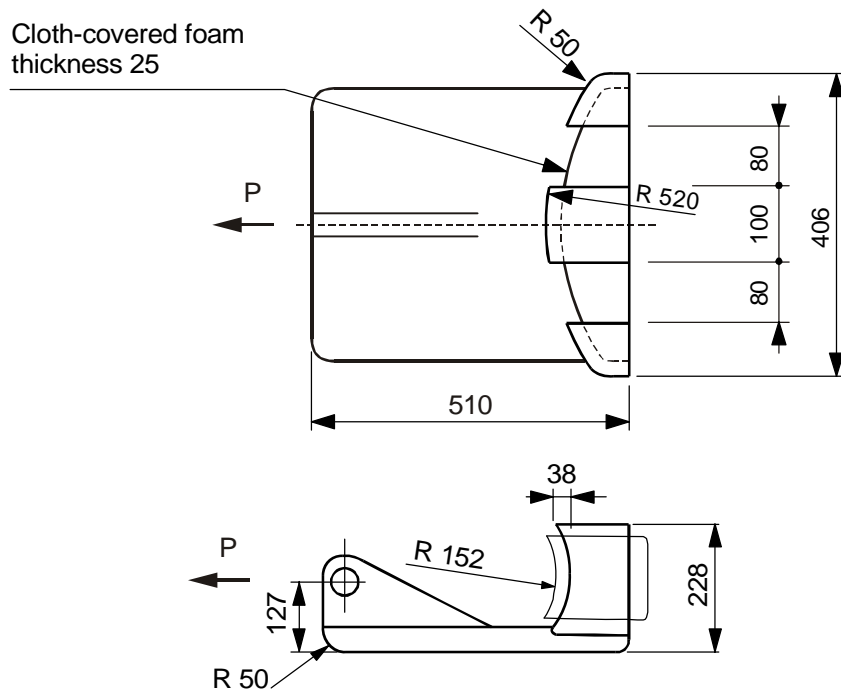

Figure 1a



For the fixing of the strap the shoulder belt traction device may be modified by adding of two land edges and/or some bolts to avoid any drop off of the strap during the pull test.



All dimensions are in mm

Figure 3

Annex 6

MINIMUM NUMBER OF ANCHORAGE POINTS
AND LOCATION OF LOWER ANCHORAGES

VEHICLE CATEGORY	FORWARD FACING SEATING POSITIONS				REAR FACING
	OUTBOARD		CENTRE		
	FRONT	OTHER	FRONT	OTHER	
M ₁	3	3	3	3	2
M ₂ ≤ 3.5 tonnes	3	3	3	3	2
M ₃ & M ₂ > 3.5 tonnes	3 ⊕	3 or 2 †	3 or 2 †	3 or 2 †	2
N ₁	3	3 or 2 ∅	3 or 2 *	2	2
N ₂ & N ₃	3	2	3 or 2 *	2	2

Key to symbols:

- 2: two lower anchorages, which allow the installation of a safety-belt type B, or of safety-belts types Br, Br3, Br4m or Br4Nm, where required by the Consolidated Resolution on the Construction of Vehicles (R.E.3), annex 13, appendix 1.
- 3: two lower anchorages and one upper anchorage which allow the installation of a three-point safety-belt type A, or of safety-belts types Ar, Ar4m or Ar4Nm, where required by the Consolidated Resolution on the Construction of Vehicles (R.E.3), annex 13, appendix 1.
- ∅: refers to paragraph 5.3.3. (Two anchorages permitted if a seat is inboard of a passageway)
- *: refers to paragraph 5.3.4. (Two anchorages permitted if the windscreen is outside reference zone)
- †: refers to paragraph 5.3.5. (Two anchorages permitted if nothing is in the reference zone)
- ⊕: refers to paragraph 5.3.7. (Special provision for the upper deck of a vehicle)

Annex 6 - Appendix 1

LOCATION OF LOWER ANCHORAGES - ANGLE REQUIREMENTS ONLY

SEAT		M ₁	OTHER THAN M ₁
Front */	buckle side (α_2)	45° - 80°	30° - 80°
	other than buckle side (α_1)	30° - 80°	30° - 80°
	angle constant	50° - 70°	50° - 70°
	bench - buckle side (α_2)	45° - 80°	20° - 80°
	bench - other than buckle side (α_1)	30° - 80°	20° - 80°
	adjustable seat with seat back angle < 20°	45° - 80° (α_2) */ 20° - 80° (α_1) */	20° - 80°
Rear ≠		30° - 80°	20° - 80° Ψ
Folding	No belt anchorage required. If anchorage fitted: see angle requirements Front and Rear.		

Notes:

≠: outboard and centre.

*/: if angle is not constant see paragraph 5.4.2.1.

Ψ: 45° - 90° in the case of seats on M₂ and M₃ vehicles.

Annex 7

DYNAMIC TEST AS AN ALTERNATIVE TO THE SAFETY-BELT ANCHORAGES
STATIC STRENGTH TEST

1. SCOPE

This annex describes a dynamic sled test that can be performed as an alternative to the safety-belt anchorages static strength test prescribed in paragraphs 6.3. and 6.4. of this Regulation.

This alternative can apply at the request of the car manufacturer in the case of a group of seats where all the seating positions are equipped with 3-point safety-belts to which thorax load limiter functions are associated and when the group of seats additionally comprises a seating position for which the upper safety-belt anchorage is located on the seat structure.

2. PRESCRIPTIONS

2.1. In the dynamic test prescribed in paragraph 3. of this annex, there shall be no rupture of any anchorage or surrounding area. A programmed rupture necessary for the functioning of the load limiter device is however permitted.

The minimum spacings for the effective lower anchorages specified in paragraph 5.4.2.5. of this Regulation, and the requirements for the effective upper anchorages specified in paragraph 5.4.3.6. of this Regulation and, when applicable, completed by the following paragraph 2.1.1., shall be respected.

2.1.1. For vehicles of category M₁ of a total permissible mass not exceeding 2.5 tonnes, the upper safety-belt anchorage, if attached to the seat structure, shall not be displaced forward of a transverse plane passing through the R point and point C of the seat in question (see figure 1 of annex 3 to this Regulation).

For vehicles other than mentioned above, the upper safety-belt anchorage shall not be displaced forward of a transverse plane inclined 10° in forward direction and passing through the R point of the seat.

2.2. In vehicles where such devices are used, the displacement and locking devices enabling the occupants of all seats to leave the vehicle must still be operable by hand after the test.

page 60
Annex 7

2.3. The vehicle owner's manual shall include indications that each safety-belt shall only be replaced by an approved safety-belt for the considered seating position in the vehicle, and shall in particular identify those seating positions which may only be fitted with an appropriate safety-belt equipped with a load limiter.

3. DYNAMIC TEST CONDITIONS

3.1. General conditions

The general conditions described in paragraph 6.1. of this Regulation apply to the test described in this annex.

3.2. Installation and preparation

3.2.1. Sled

The sled must be so constructed that no permanent deformation appears after the test. It must be so guided that, during the impact phase, the deviation does not exceed 5° in the vertical plane and 2° in the horizontal plane.

3.2.2. Securing of the vehicle structure

The part of the vehicle structure considered essential for the vehicle rigidity regarding the seat anchorages and the safety-belt anchorages shall be secured on the sled, according to the disposals described in paragraph 6.2. of this Regulation.

3.2.3. Restraint systems

3.2.3.1. The restraint systems (the complete seats, the safety-belt assemblies and the load limiter devices) shall be mounted on the vehicle structure according to the series production vehicle specifications.

The vehicle environment facing the tested seat (dashboard, seat, etc., depending on the tested seat) can be mounted on the test sled. If there were a frontal airbag, it has to be deactivated.

3.2.3.2. At the request of the car manufacturer and in agreement with the technical service in charge of the tests, some components of the restraint systems other than the complete seats, the safety-belt assemblies and the load limiter devices, may not be mounted on the test sled or may be replaced by components having equivalent or lower stiffness and whose dimensions are comprised in the vehicle interior fittings dimensions, provided that the tested configuration is at least as unfavourable as the series configuration regarding the forces applying to the seat and safety-belt anchorages.

3.2.3.3. The seats shall be adjusted as required in paragraph 6.1.2. of this Regulation, in the position for use chosen by the technical service in charge of the tests as the one giving the most adverse conditions regarding the anchorages strength and compatible with the installation of the dummies in the vehicle.

3.2.4. Dummies

A dummy whose dimensions and mass are defined in annex 8 shall be positioned on each seat and restrained by the safety-belt provided in the vehicle.

No dummy instrumentation is required.

3.3. Test

3.3.1. The sled shall be so propelled that, during the test, its speed variation is 50 km/h. The sled deceleration shall be within the corridor specified in annex 8 of Regulation No. 16.

3.3.2. If applicable, the activation of additional restraining devices (preloading devices, etc., except airbags) is triggered according to the car manufacturer's indications.

3.3.3. It shall be checked that the safety-belt anchorages' displacement does not exceed the limits specified in paragraphs 2.1. and 2.1.1. of this annex.

Annex 8

DUMMY SPECIFICATIONS */

Mass	97.5 ± 5 kg
Erect sitting height	965 mm
Hip breadth (sitting)	415 mm
Hip circumference (sitting)	1200 mm
Waist circumference (sitting)	1080 mm
Chest depth	265 mm
Chest circumference	1130 mm
Shoulder height	680 mm
Tolerance on all length dimensions	± 5 per cent

Remark: a sketch explaining the dimensions is given in the figure below.

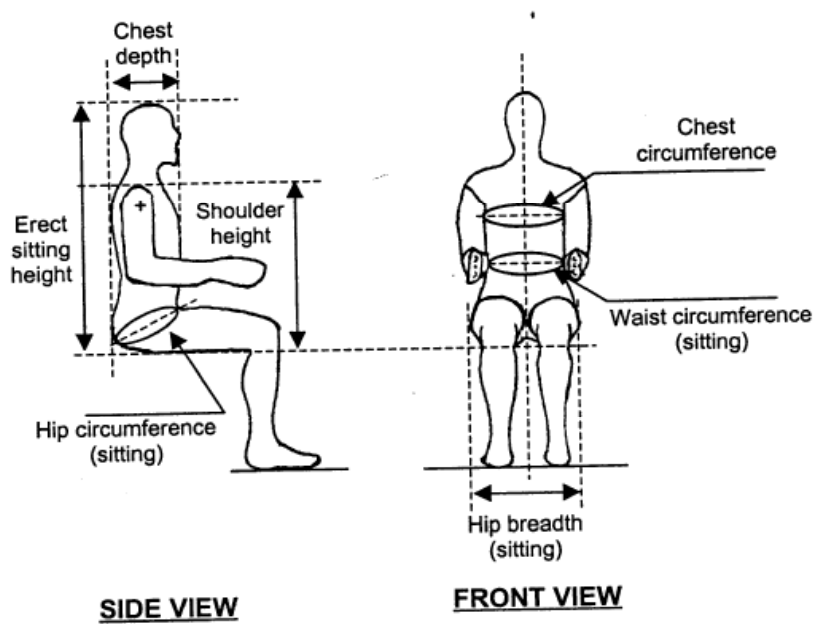

*/ Devices described in the Australian Design Rule (ADR) 4/03 and Federal Motor Vehicle Safety Standard (FMVSS) No. 208 are considered equivalent.

Annex 9

ISOFIX ANCHORAGES SYSTEMS AND ISOFIX TOP TETHER ANCHORAGES

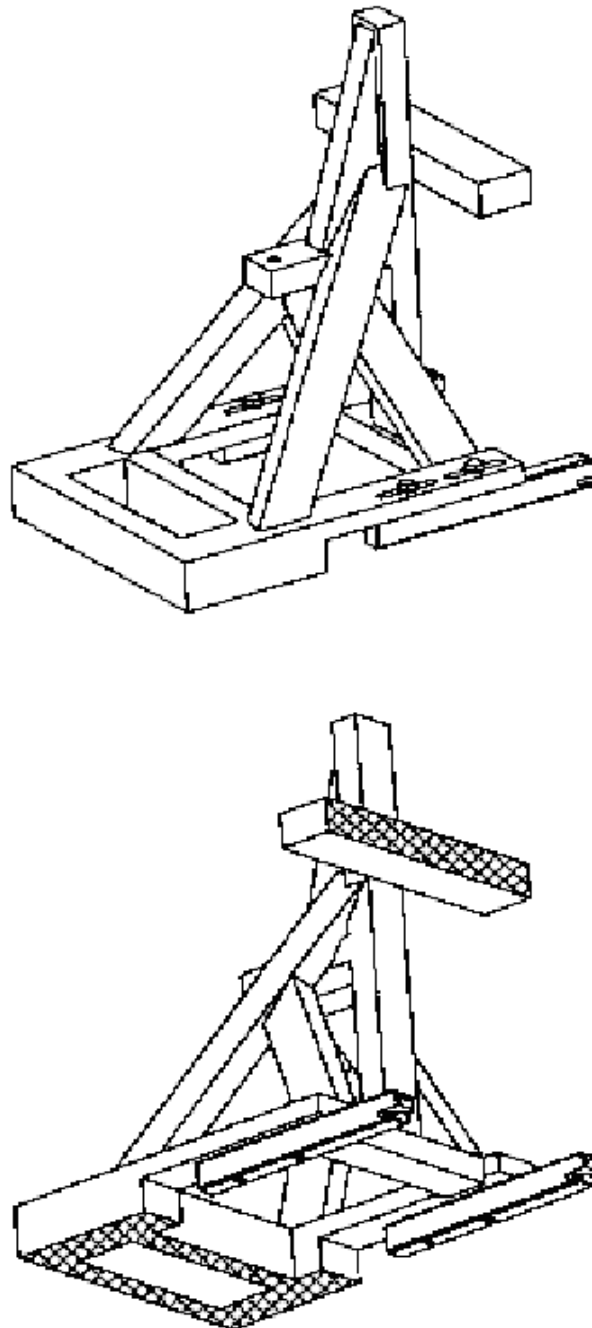
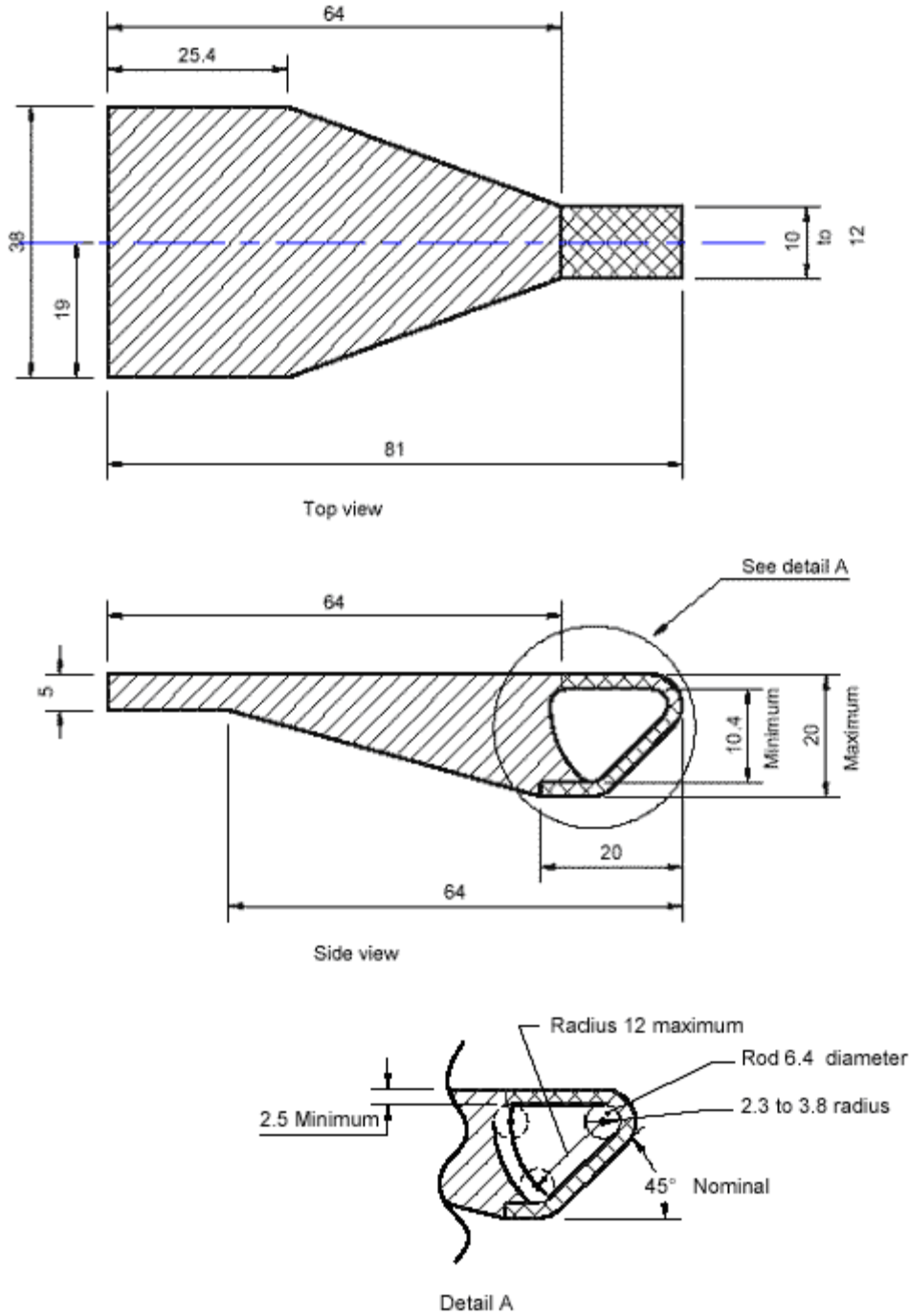

Figure 1: Static force application device (SFAD), isometric views

page 65
Annex 9

Stiffness of SFAD: When attached to rigid anchorage bar(s) with the front cross member of the SFAD supported by a rigid bar that is held at the centre by a longitudinal pivot 25 mm below the SFAD base (to allow bending and twisting of the SFAD base) the movement of point X shall not be greater than 2 mm in any direction when forces are applied in accordance with table No. 1 of paragraph 6.6.4. of this Regulation. Any deformation of the ISOFIX anchorages system shall be excluded from the measurements

Dimensions in millimetres



LEGEND:



-  Surrounding structure (if present)
-  Area in which the tether strap hook interface profile must be wholly located.

Figure 3: ISOFIX Top tether connector (hook type) dimensions

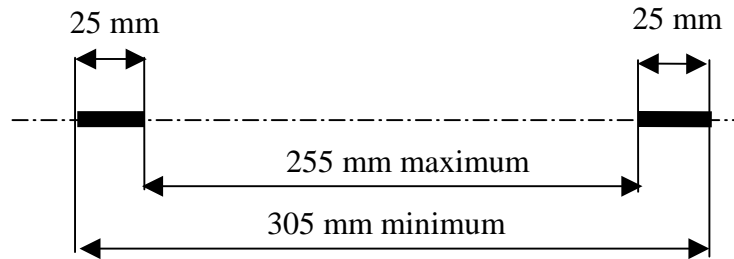

Figure 4: Distance between both low anchorage zones

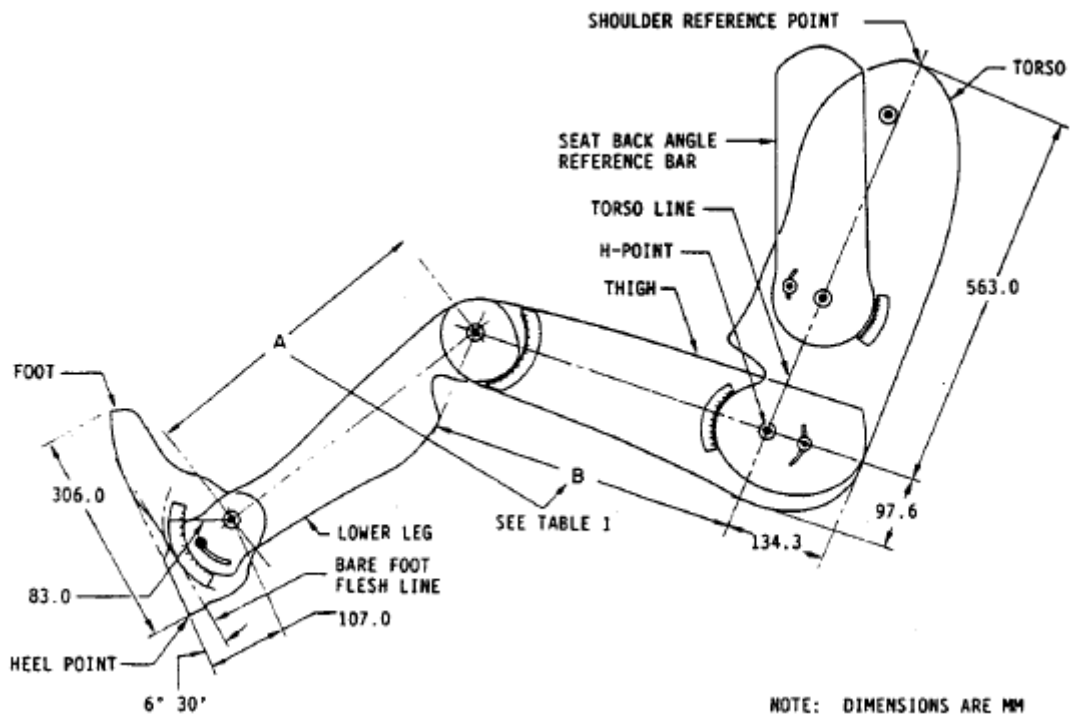
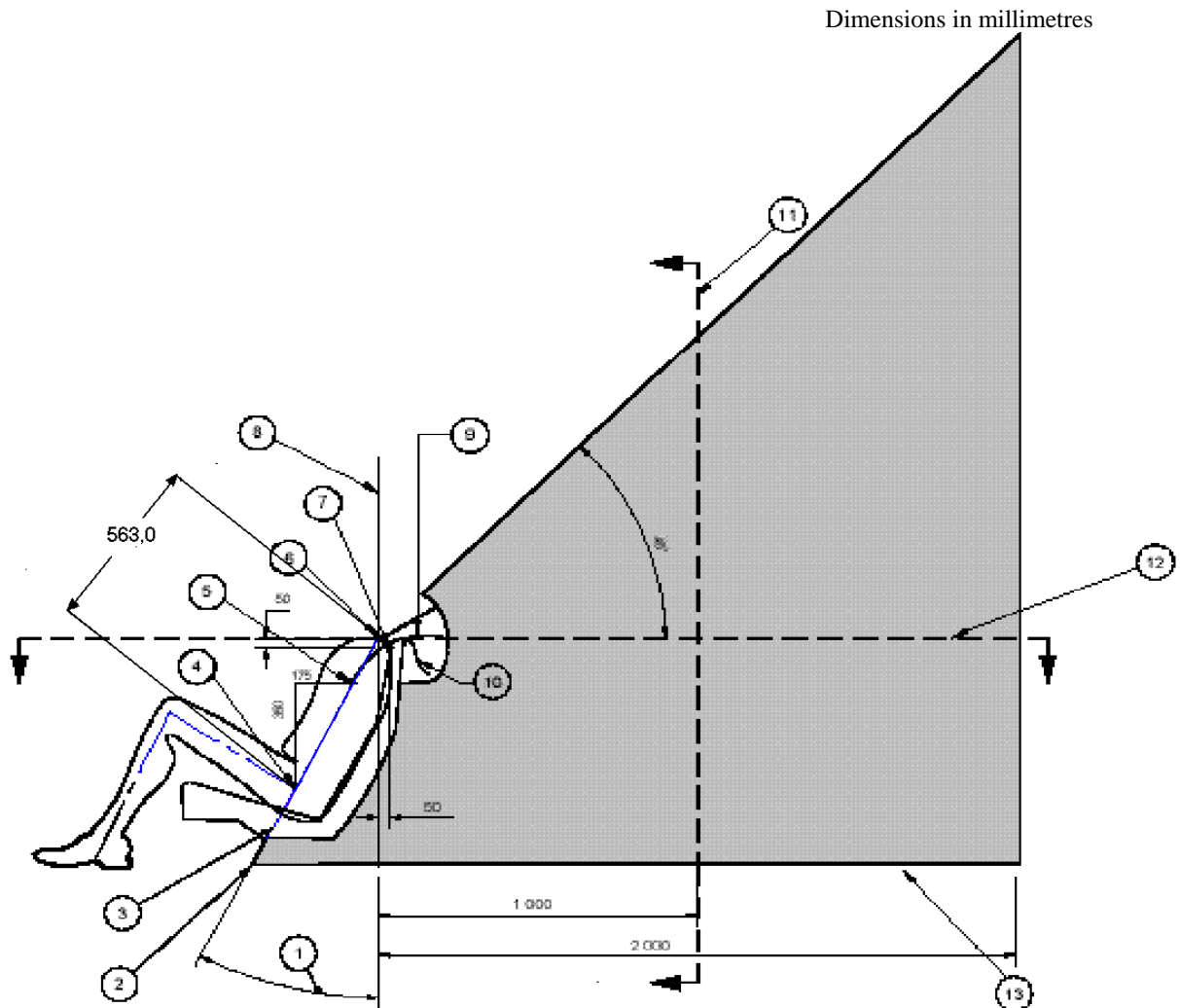

Figure 5: Two dimensions template



Key

- 1 Back angle
- 2 Intersection of torso line reference plane and floor pan
- 3 Torso line reference plane
- 4 H-point
- 5 "V" point
- 6 "R" point
- 7 "W" point
- 8 Vertical longitudinal plane
- 9 Strap wrap-around length from "V" point: 250 mm
- 10 Strap wrap-around length from "W" point: 200 mm
- 11 "M" plane cross-section
- 12 "R" plane cross-section
- 13 Line represents the vehicle specific floor pan surface within the prescribed zone

NOTE 1 Portion of top tether anchorage that is designed to bind with the top tether hook to be located within shaded zone

NOTE 2 "R" Point: Shoulder reference point

NOTE 3 "V" Point: V-reference point, 350 mm vertically above and 175 mm horizontally back from H-point

NOTE 4 "W" Point: W-reference point, 50 mm vertically below and 50 mm horizontally back from "R" point

NOTE 5 "M" Plane: M-reference plane, 1 000 mm horizontally back from "R" point

NOTE 6 The forwardmost surfaces of the zone are generated by sweeping the two wraparound lines throughout their extended range in the front part of the zone. The wraparound lines represent the minimum adjusted length of typical top tether straps extending from either the top of the CRS (W-point), or lower on the back of the CRS (V-point).

Figure 6: ISOFIX Top tether anchorage location, ISOFIX zone - Side view

Dimensions in millimetres

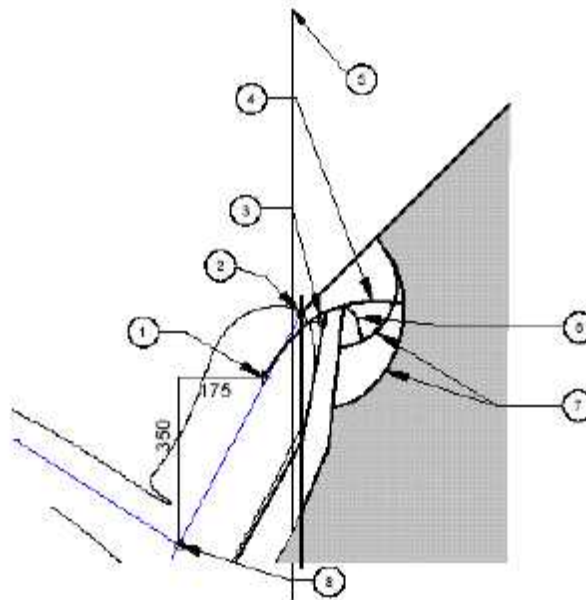

Key

- 1 "V" point
- 2 "R" point
- 3 "W" point
- 4 Strap wrap-around length from "V" point: 250 mm
- 5 Vertical longitudinal plane
- 6 Strap wrap-around length from "W" point: 200 mm
- 7 Arcs created by wrap-around lengths
- 8 H-point

- NOTE 1 Portion of top tether anchorage that is designed to bind with the top tether hook to be located within shaded zone
- NOTE 2 "R" point: Shoulder reference point
- NOTE 3 "V" point: V-reference point, 350 mm vertically above and 175 mm horizontally back from H-point
- NOTE 4 "W" point: W-reference point, 50 mm vertically below and 50 mm horizontally back from "R" point
- NOTE 5 "M" plane: M-reference plane, 1000 mm horizontally back from "R" point
- NOTE 6 The forwardmost surfaces of the zone are generated by sweeping the two wraparound lines throughout their extended range in the front part of the zone. The wraparound lines represent the minimum adjusted length of typical top tether straps extending from either the top of the CRS (W-point), or lower on the back of the CRS (V-point).

Figure 7: ISOFIX Top tether anchorage location, ISOFIX zone - Enlarged side view of wrap-around area

Dimensions in millimetres

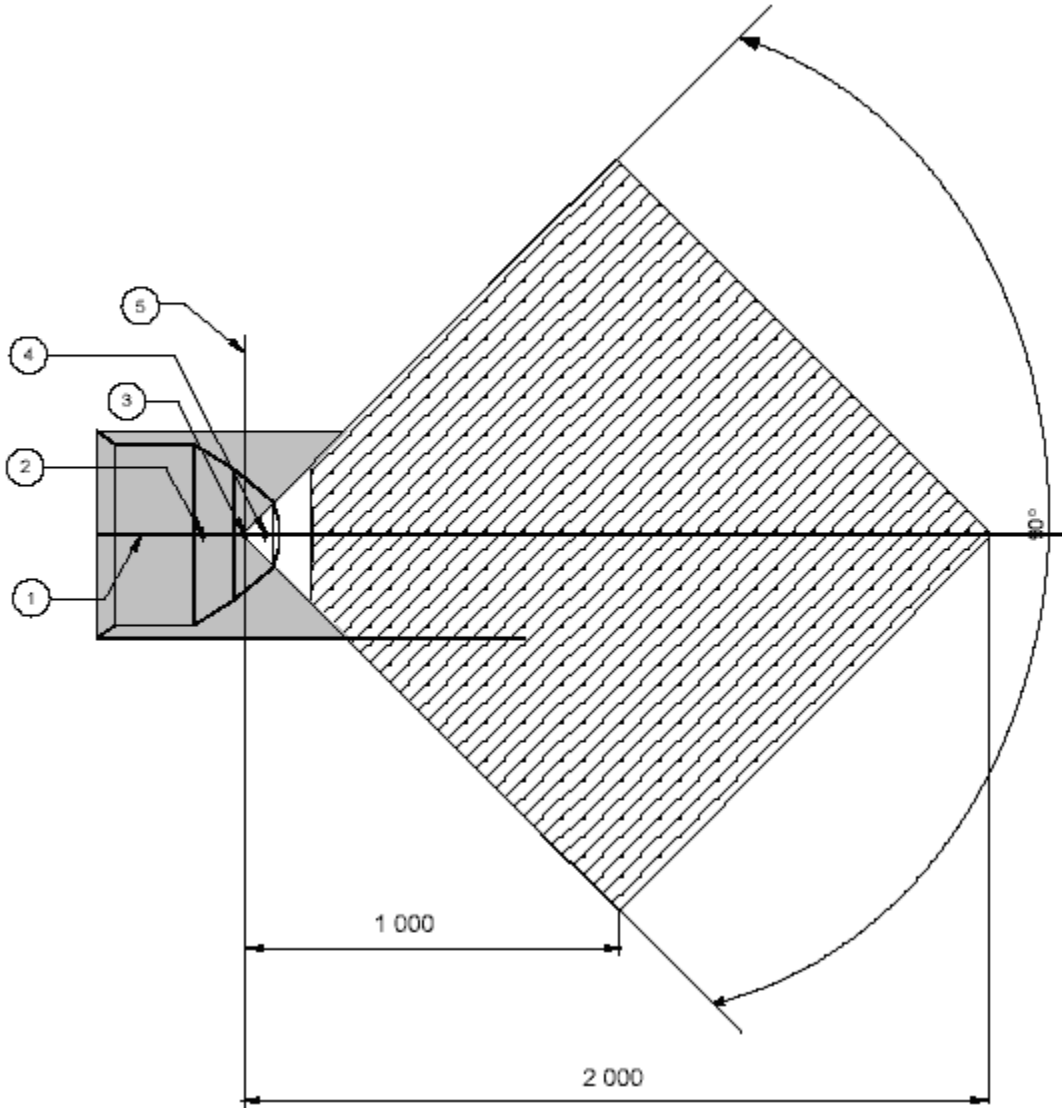

Key

- 1 Median plane
- 2 "V" point
- 3 "R" point
- 4 "W" point
- 5 Vertical longitudinal plane

NOTE 1 Portion of top tether anchorage that is designed to bind with the top tether hook to be located within shaded zone

NOTE 2 "R" point: Shoulder reference point

NOTE 3 "V" point: V-reference point, 350 mm vertically above and 175 mm horizontally back from H-point

NOTE 4 "W" point: W-reference point, 50 mm vertically below and 50 mm horizontally back from "R" point

Figure 8: SOFIX Top tether anchorage location, ISOFIX zone - Plan view
 (R-plane cross section)

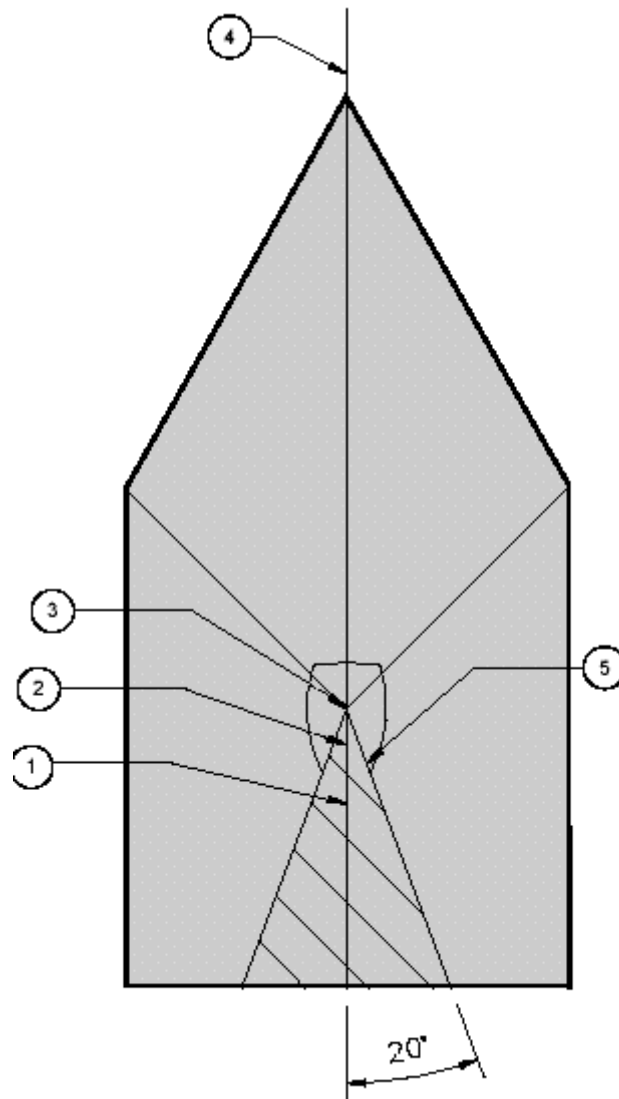

Key

- 1 "V" point
- 2 "W" point
- 3 "R" point
- 4 Median plane
- 5 Area view along torso reference plane

NOTE 1 Portion of top tether anchorage that is designed to bind with the top tether hook to be located within shaded zone

NOTE 2 "R" point: Shoulder reference point

NOTE 3 "V" point: V-reference point, 350 mm vertically above and 175 mm horizontally back from H-point

NOTE 4 "W" point: W-reference point, 50 mm vertically below and 50 mm horizontally back from "R" point

Figure 9: ISOFIX Top tether anchorage location, ISOFIX zone - Front view

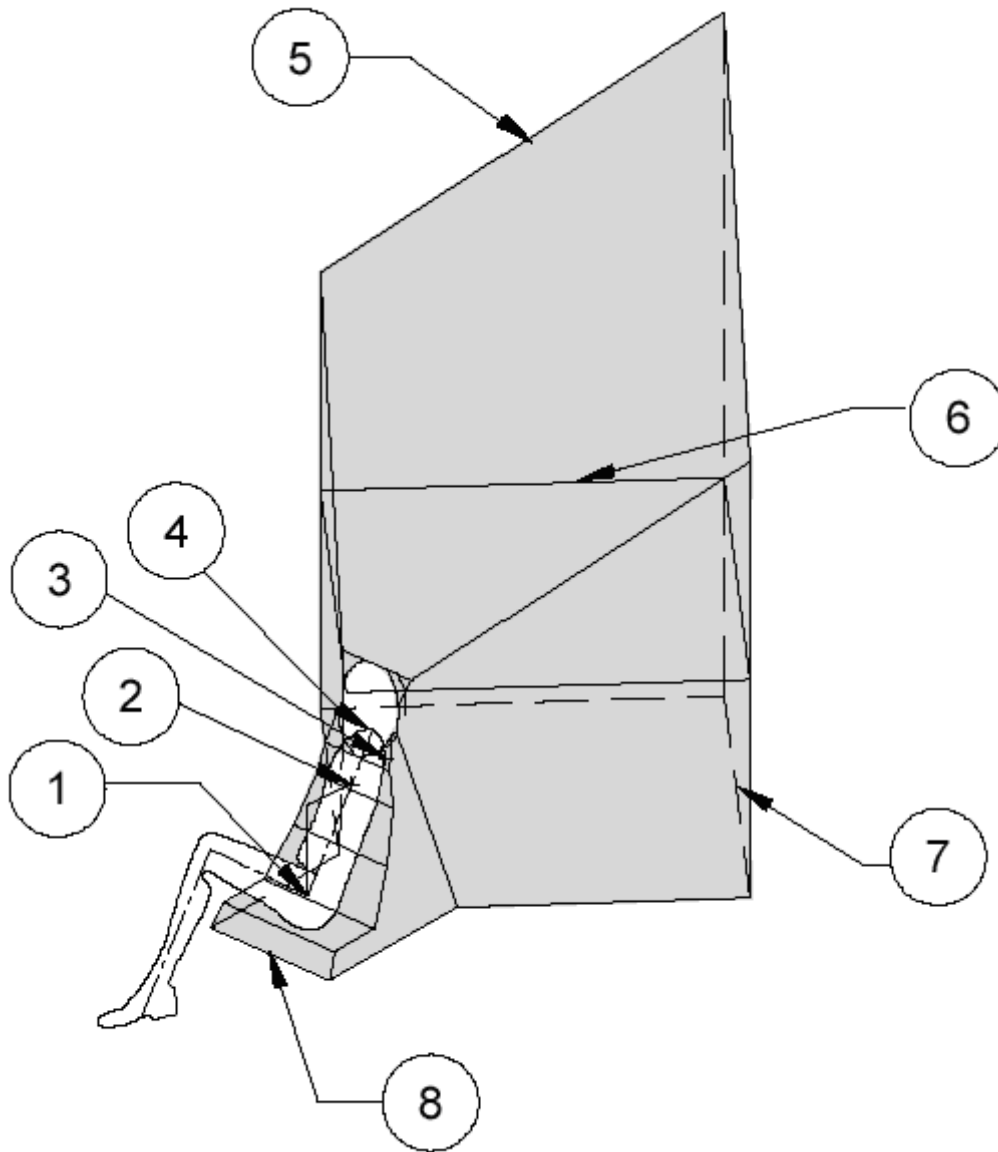

Key

- 1 H-point
- 2 "V" point
- 3 "W" point
- 4 "R" point
- 5 45° plane
- 6 "R" plane cross-section
- 7 Floor pan surface
- 8 Front edge of zone

NOTE 1 Portion of top tether anchorage that is designed to bind with the top tether hook to be located within shaded zone

NOTE 2 "R" point: Shoulder reference point

Figure 10: ISOFIX Top tether anchorage location, ISOFIX zone -
Three-dimensional schematic view

Dimensions in millimetres

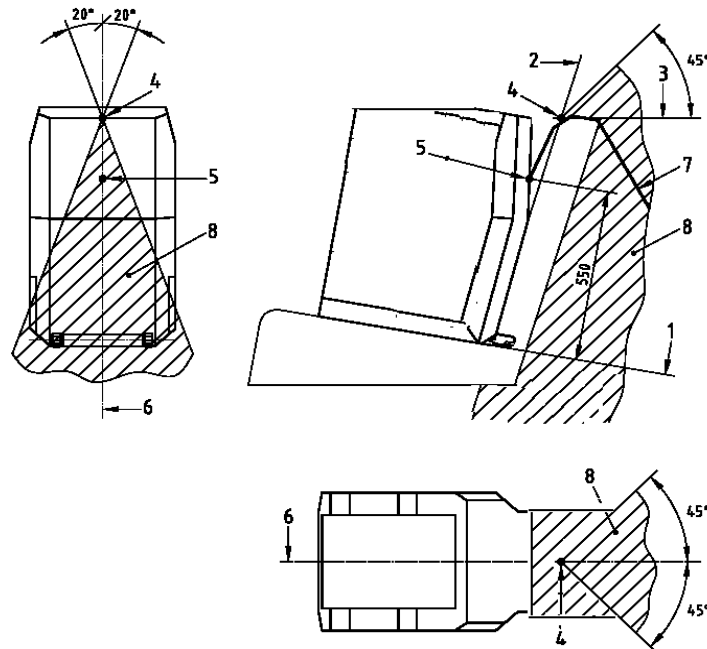

Figure 11: Alternative method of locating the top tether anchorage using the "ISO/F2" (B) fixture, ISOFIX zone - side, top and rear views

- | | | | |
|---|--|---|---------------------------------|
| 1 | "ISO/F2" (B) fixture horizontal face | 4 | intersection between 2 and 3 |
| 2 | "ISO/F2" (B) fixture rear face | 5 | tether reference point |
| 3 | horizontal line tangent to top of seat back (last rigid point of a hardness greater than 50 Shore A) | 6 | "ISO/F2" (B) fixture centreline |
| | | 7 | top tether strap |
| | | 8 | limits of anchorage zone |



Notes:

1. Drawing not to scale.
2. Symbol may be shown in mirror image.
3. Colour of the symbol at choice of manufacturer.

Figure 12: ISOFIX low anchorage symbol

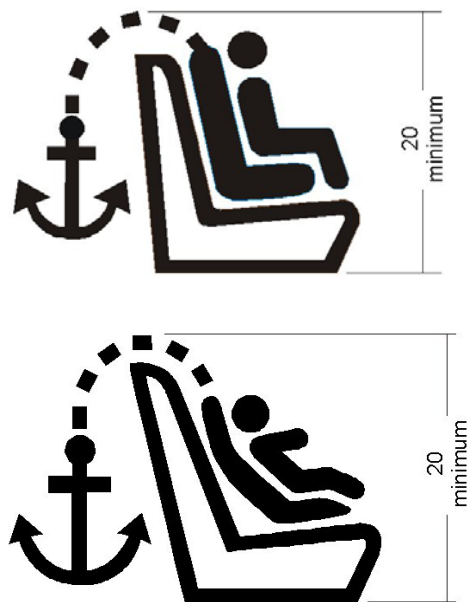

Notes:

1. Dimensions in mm
2. Drawing not to scale
3. The symbol shall be clearly visible either by means of contrast colours or by adequate relief if it is moulded or embossed.

Figure 13: Symbol used to identify the location of a top tether anchorage that is under a cover
