

**มาตรฐานผลิตภัณฑ์อุตสาหกรรม**

**THAI INDUSTRIAL STANDARD**

**มอก. 2354 – 2550**

**ECE Regulation No.60**

**00 series of amendments**

**การควบคุมการขับขี่สำหรับรถจักรยานยนต์สองล้อ  
และรถจักรยานเสริมเครื่องยนต์**

**DRIVER - OPERATED CONTROLS FOR TWO - WHEELED MOTOR CYCLES  
AND MOPEDS**

**สำนักงานมาตรฐานผลิตภัณฑ์อุตสาหกรรม**

**กระทรวงอุตสาหกรรม**

ICS 43.040.30

ISBN 978-974-292-594-9

มาตรฐานผลิตภัณฑ์อุตสาหกรรม  
การควบคุมการขั้วขึ้นสำหรับรถจักรยานยนต์สองล้อ  
และรถจักรยานเสริมเครื่องยนต์

มอก. 2354 — 2550

สำนักงานมาตรฐานผลิตภัณฑ์อุตสาหกรรม  
กระทรวงอุตสาหกรรม ถนนพระรามที่ 6 กรุงเทพฯ 10400  
โทรศัพท์ 0 2202 3300

ประกาศในราชกิจจานุเบกษา ฉบับประกาศและงานทั่วไป เล่ม 126 ตอนพิเศษ 21 ง  
วันที่ 10 กุมภาพันธ์ พุทธศักราช 2552

การควบคุมการขับขี่เป็นสิ่งจำเป็นและสำคัญสำหรับยานยนต์ ทั้งนี้เพื่อให้เกิดความปลอดภัยแก่ผู้บริโภค และเพื่อเป็นการส่งเสริมอุตสาหกรรม จึงกำหนดมาตรฐานผลิตภัณฑ์อุตสาหกรรม การควบคุมการขับขี่สำหรับรถจักรยานยนต์ สองล้อ และรถจักรยานเสริมเครื่องยนต์ ขึ้น

มาตรฐานผลิตภัณฑ์อุตสาหกรรมนี้กำหนดโดยรับ Economic Commission for Europe (ECE) Regulation No.60 UNIFORM PROVISIONS CONCERNING THE APPROVAL OF TWO-WHEELED MOTOR CYCLES AND MOPEDS WITH REGARD TO DRIVER-OPERATED CONTROLS INCLUDING THE IDENTIFICATION OF CONTROLS, TELL-TALES AND INDICATORS ดังต่อไปนี้

1. Regulation No.60
2. Regulation No.60 Amendment 1  
Supplement 1 to this Regulation in its original
3. Regulation No.60 Amendment 2  
Supplement 2 to the original version of the Regulation

มาใช้ในระดับเหมือนกันทุกประการ (identical) เฉพาะสาระสำคัญทางวิชาการ ซึ่งแสดงถึงคุณลักษณะที่ต้องการทั่วไป คุณลักษณะที่ต้องการเป็นพิเศษ

สำหรับข้อกำหนดด้านการรับรองหรือการดำเนินการต่าง ๆ ที่เกี่ยวข้องให้เป็นไปตามพระราชบัญญัติมาตรฐานผลิตภัณฑ์อุตสาหกรรม โดยสำนักงานมาตรฐานผลิตภัณฑ์อุตสาหกรรมจะประกาศกำหนดหลักเกณฑ์การรับรองต่อไป

คณะกรรมการมาตรฐานผลิตภัณฑ์อุตสาหกรรมได้พิจารณามาตรฐานนี้แล้ว เห็นสมควรเสนอรัฐมนตรีประกาศตาม มาตรา 15 แห่งพระราชบัญญัติมาตรฐานผลิตภัณฑ์อุตสาหกรรม พ.ศ. 2511



**ประกาศกระทรวงอุตสาหกรรม**

**ฉบับที่ 3890 (พ.ศ. 2551)**

ออกตามความในพระราชบัญญัติมาตรฐานผลิตภัณฑ์อุตสาหกรรม

พ.ศ. 2511

เรื่อง กำหนดมาตรฐานผลิตภัณฑ์อุตสาหกรรม

การควบคุมการขับขี่สำหรับรถจักรยานยนต์สองล้อ และรถจักรยานเสริมเครื่องยนต์

---

อาศัยอำนาจตามความในมาตรา 15 แห่งพระราชบัญญัติมาตรฐานผลิตภัณฑ์อุตสาหกรรม พ.ศ. 2511 รัฐมนตรีว่าการกระทรวงอุตสาหกรรมออกประกาศกำหนดมาตรฐานผลิตภัณฑ์อุตสาหกรรม การควบคุมการขับขี่สำหรับรถจักรยานยนต์สองล้อ และรถจักรยานเสริมเครื่องยนต์ มาตรฐานเลขที่ มอก. 2354-2550 ไว้ดังมีรายละเอียดต่อท้ายประกาศนี้

ประกาศ ณ วันที่ 22 กรกฎาคม พ.ศ. 2551

**สุวิทย์ คุณกิตติ**

รัฐมนตรีว่าการกระทรวงอุตสาหกรรม

# มาตรฐานผลิตภัณฑ์อุตสาหกรรม การควบคุมการขับขี่สำหรับรถจักรยานยนต์สองล้อ และรถจักรยานเสริมเครื่องยนต์

## ขอบข่าย

มาตรฐานผลิตภัณฑ์อุตสาหกรรมนี้ครอบคลุมส่วนที่ใช้สำหรับควบคุมการขับขี่ของรถจักรยานยนต์สองล้อและรถจักรยานเสริมเครื่องยนต์ รวมถึงตัวชี้บ่งสถานะการควบคุมไฟแจ้งเตือนและอุปกรณ์หน้าปัดต่างๆ

## บทนิยาม

ความหมายของคำที่ใช้ในมาตรฐานผลิตภัณฑ์อุตสาหกรรมนี้ ให้เป็นไปตาม ECE Regulation No. 60

## ข้อกำหนด

มาตรฐานผลิตภัณฑ์อุตสาหกรรมนี้กำหนดคุณลักษณะทั่วไป คุณลักษณะที่ต้องการเป็นพิเศษ ตามรายละเอียดใน ECE Regulation No. 60 ข้อ 5. และข้อ 6.

## การทดสอบ

การทดสอบและการหาค่าต่างๆ ตามมาตรฐานผลิตภัณฑ์อุตสาหกรรมนี้ ให้เป็นไปตามรายละเอียดใน ECE Regulation No. 60 ANNEX ที่เกี่ยวข้อง

**អង្គ. 2354—2550**  
**ECE Regulation No. 60**  
**00 series of amendments**

Regulation No. 60

UNIFORM PROVISIONS CONCERNING THE APPROVAL OF TWO-WHEELED MOTOR CYCLES  
AND MOPEDS WITH REGARD TO DRIVER-OPERATED CONTROLS INCLUDING  
THE IDENTIFICATION OF CONTROLS, TELL-TALES AND INDICATORS

CONTENTS

REGULATION

	<u>Page</u>
1. Scope .....	1
2. Definitions .....	1
3. Application for approval .....	3
4. Approval .....	3
5. General requirements .....	5
6. Special requirements .....	5
7. Modifications of the vehicle type .....	9
8. Conformity of production .....	9
9. Penalties for non-conformity of production .....	9
10. Production definitely discontinued .....	10
11. Names and addresses of technical services responsible for conducting approval tests, and of administrative departments ... .....	10
12. Transitional provisions .....	10

ANNEXES

- ANNEX 1 - Communication concerning the approval (or refusal or withdrawal of approval or production definitely discontinued) of a vehicle type with regard to driver-operated controls pursuant to Regulation No.60
- Annex 2 - Arrangements of approval marks
- Annex 3 - Special provisions relating to levers
- Annex 4 - Controls, tell-tales and indicators for which, when fitted identification is mandatory, and symbols to be used for that purpose.

**អង្គ. 2354—2550**  
**ECE Regulation No. 60**  
**00 series of amendments**



Regulation No. 60

UNIFORM PROVISIONS CONCERNING THE APPROVAL OF TWO-WHEELED MOTOR CYCLES AND MOPEDS WITH REGARD TO DRIVER-OPERATED CONTROLS INCLUDING THE IDENTIFICATION OF CONTROLS, TELL-TALES AND INDICATORS

1. SCOPE

This Regulation applies to two-wheeled motor cycles and two-wheeled mopeds with regard to driver-operated controls including the identification of controls, tell-tales and indicators.

2. DEFINITIONS

For the purposes of this Regulation:

- 2.1. "Approval of a vehicle" means the approval of a vehicle type with regard to driver-operated controls, where such controls are fitted and to their identification;
- 2.2. "Vehicle type" means a category of power-driven vehicles which do not differ in respect of the arrangements which may affect the function or position of the driver-operated controls;
- 2.3. "Vehicle" means a two-wheeled motor cycle as defined in article 1 (n) or a two-wheeled moped as defined in article 1 (m) of the United Nations Convention on Road Traffic, Vienna 1968;
- 2.4. "Control" means any part of the vehicle or a device directly actuated by the driver which changes the state or functioning of the vehicle or any part thereof;
- 2.5. "Handlebars" means any part of the bar or bars connected to the head of the forks (steering head) by means of which the vehicle is steered;
- 2.5.1. "Handlebars: right side" means any part of the handlebars which, when facing the direction of forward movement, lies on the right side of the longitudinal median plane of the vehicle;
- 2.5.2. "Handlebars: left side" means any part of the handlebars which, when facing the direction of forward movement, lies on the left side of the longitudinal median plane of the vehicle;
- 2.5.3. "Handlebars: forward" means any part of the handlebars lying on the side farthest from the driver when seated in a driving position;
- 2.6. "Handgrip" means that part of the handlebars, furthest from the centre, by which the handlebars are held by the driver of the vehicle;

- 2.6.1. "Rotating handgrip" means a handgrip, operating some functional mechanism of the vehicle, which is free to rotate around the handlebar when so turned by the driver of the vehicle;
- 2.7. "Frame" means any part of the frame, chassis or cradle of the vehicle, to which is attached the engine and/or transmission unit, and/or the engine and transmission unit itself;
- 2.7.1. "Frame: right side" means any part of direction of forward movement, lies on median plane of the vehicle;
- 2.7.2. "Frame: left side" means any part of the frame which, when facing in the direction of forward movement, lies on the left side of the longitudinal median plane of the vehicle;
- 2.8. "Lever" means any device consisting of an arm turning on a fulcrum, by means of which some functional mechanism of the vehicle is operated;
- 2.8.1. "Hand lever" means a lever operated by the hand of the driver;  
Note: Unless otherwise stated, a hand lever is operated by compression, (that is, movement of the apex of the lever towards the supporting structure), e.g. to engage a brake mechanism or to disengage the clutch mechanism.
- 2.8.2. "Foot lever" means a lever operated by contact between the foot of the driver and a spur projecting from the arm of the lever;
- 2.8.3. "Pedal" means a lever operated by contact between the foot of the driver and a part on the lever, so placed as to allow pressure to be applied to the arm of the lever;  
Note: Unless otherwise stated, a pedal is operated by depression, for example to engage a brake mechanism.
- 2.8.4. "Riding pedals" means those devices which are linked to some form of transmission and may be used to propel a moped;
- 2.8.5. "Rocker arm" means a lever, pivoted at or near its centre and having a pad or spur at each end, operated by contact between the foot of the driver and the said pads or spurs (see annex 3, figure 3);
- 2.9. "Footrest" means the projections on either side of the vehicle on which the driver places his feet, when seated in the driving position;
- 2.10. "Platform" means that part of the vehicle on which the driver places his feet, when seated in the normal driving position, in the case that the vehicle is not equipped with riding pedals or footrests for the driver;

- 2.11. "Clockwise" means the direction of rotation around the axis of the part considered, following the motion of the hands of a clock when viewed from the upper or the outer side of the part considered;
- 2.11.1. "Anticlockwise" has the inverse meaning;
- 2.12. "Combined service brake" means a system of operation (by hydraulic action or mechanical linkage, or both) whereby both the front and the rear brakes of the vehicle are brought into operation at least partially by the use of-only one control;
- 2.13. "Indicator" means a device which presents information on the functioning or situation of a system or a part of a system, for example a fluid level;
- 2.14. "Tell-tale" means an optical signal which indicates the actuation of a device, correct or defective functioning or condition, or failure to function;
- 2.15. "Symbol" means a diagram from which to identify a control, a tell-tale or an indicator.
3. APPLICATION FOR APPROVAL
- 3.1. The application for approval of a vehicle type with regard to driver-operated controls shall be submitted by the vehicle manufacturer or by his duly accredited representative.
- 3.2. It shall be accompanied by the undermentioned documents in triplicate and the following particulars:
- 3.2.1. Drawings, on an appropriate scale and in sufficient detail, of the parts of the vehicle to which the requirements of this Regulation relate and, where necessary, of the vehicle itself.
- 3.3. A vehicle representative of the vehicle type to be approved shall be submitted to the technical service responsible for conducting approval tests, for the checks referred to in paragraph 5 of this Regulation.
4. APPROVAL
- 4.1. If the vehicle type submitted for approval pursuant to this Regulation meets the requirements of paragraphs 5 and 6 below, approval of that vehicle type shall be granted.
- 4.2. An approval number shall be assigned to each type approved. Its first two digits (at present 00 for the Regulation in its original form) shall indicate the series of amendments incorporating the most recent major technical amendments made to the Regulation at the time of issue of the approval. The same Contracting Party may not assign the same number to another vehicle type.

- 4.3 Notice of approval or of refusal of approval of a vehicle type pursuant to this Regulation shall be communicated to the Parties to the Agreement applying this Regulation by means of a form conforming to the model annex 1 to this Regulation and of drawings and diagrams supplied by the applicant or approval, in a format not exceeding A 4 (210 x 297 mm) or folded to that format and on an appropriate scale.
- 4.4 There shall be affixed, conspicuously and in a readily accessible place specified on the approval form, to every vehicle conforming to a vehicle type approved under this Regulation an international approval mark consisting of:
- 4.4.1 a circle surrounding the letter "E" followed by the distinguishing number of the country which has granted approval;<sup>1/</sup>
- 4.4.2 the number of this Regulation, followed by the letter "R" a dash and the approval number to the right of the circle prescribed in paragraph 4.4.1.
- 4.5 If the vehicle conforms to a vehicle type approved, under one or more other Regulations annexed to the Agreement, in the country which has granted approval under this Regulation, the symbol prescribed in paragraph 4.4.1. need not be repeated; in such a case, the Regulation and approval numbers and the additional symbols of all the Regulations under which approval has been granted in the country which has granted approval under this Regulation shall be placed in vertical columns to the right of the symbol prescribed in paragraph 4.4.1.
- 4.6 The approval mark shall be clearly legible and shall be indelible.
- 4.7 The approval mark shall be readily accessible.
- 4.8 Annex 2 to this Regulation gives examples of arrangements of approval marks.

---

<sup>1/</sup> 1 for the Federal Republic of Germany, 2 for France, 3 for Italy, 4 for the Netherlands, 5 for Sweden, 6 for Belgium, 7 for Hungary, 8 for Czechoslovakia, 9 for Spain, 10 for Yugoslavia, 11 for the United Kingdom, 12 for Austria, 13 for Luxembourg, 14 for Switzerland, 15 for, the German Democratic Republic, 16 for Norway, 17 for Finland, 18 for Denmark, 19 for Romania, 20 for Poland and 21 for Portugal. Subsequent numbers shall be assigned to other countries in the chronological order in which they ratify or accede to the Agreement concerning the Adoption of Uniform , Conditions of Approval and Reciprocal Recognition of Approval for Motor Vehicle Equipment and Parts, and the numbers thus assigned shall be communicated by the Secretary-General of the United Nations to the Contracting Parties to the Agreement.

5 GENERAL REQUIREMENTS

5.1 All. the driver-operated controls specified in paragraph 6.1., 6.2., 6.3., and 6.4., shall be within the reach of the driver when seated in the driving position.

5.1.1 The driver's reach to the controls shall not be impeded by the intrusion of any other control or any part of the structure of the vehicle.

5.1.2 The controls detailed in paragraphs 6.1. to 6.4. below shall be located in the positions or in the specified areas indicated in those paragraphs.

5.1.3 The position of the controls on the handlebars specified in

paragraph 6.2.1. (Front brake)

paragraph 6.2.2.2. (Rear brake: mopeds)

paragraph 6.3.1 (Clutch)

paragraph 6.4.1. (Audible warning device)

paragraph 6.4.2.2. (Driving beam / Passing beam control)

paragraph 6.4.3. (Direction indicators control)

shall be such that they can be reached without the removal of the driver's hands from the respective handgrips.

5.2 The controls detailed in paragraphs 6.2.1., 6.2.2., 6.2.3. and 6.3.1. shall be so designed as to comply with the requirements of annex 3, Part one (Hand levers) or Part two (Foot levers, Rocker arms and Pedals) respectively.

5.3 Identification

5.3.1 The controls, tell-tales and indicators, when fitted shall be identified in accordance with the provisions of annex 4.

6 SPECIAL REQUIREMENTS

6.1 Engine controls

6.1.1 Starting

6.1.1.1 Engine ignition switch: In the case of a rotary switch, the direction of motion shall be clockwise from the ignition "off " position to the ignition "on" position.

6.1.1.2 Starter switch: No special requirement.

6.1.1.3 Combined ignition/starter switch: In the case of a rotary switch, the direction of motion shall be clockwise, passing from the "off " position to the ignition "on" position to the starter energizing position.

6.1.2 Speed

6.1.2.1 Speed control: The speed of the engine shall be controlled by a hand-operated control.

Position of control: on handlebars: right side.

Type of control: rotating handgrip on handlebars.

Direction of rotation: anticlockwise to increase speed.

6.1.3 Stop

6.1.3.1 Engine cut-out:

As a means of stopping the engine, alternative to the main switch (paragraph 6.1.1.1.) or a decompression valve control (paragraph 6.1.3.2. below), the vehicle may be equipped with an engine electrical power supply cut-out.

Position of control: on handlebars: right side.

6.1.3.2 Manual decompression control:

Position of control: on handlebars

Type of control: Lever, or

Rotating handgrip, provided that it is combined with the speed control (right side)

6.2 Brakes

6.2.1 Front (wheel) brake:

Position of control: on handlebars: right side forward

Type of control: hand lever

6.2.2 Rear (wheel) brake:

6.2.2.1 Vehicles equipped with manually operated clutch:

Position of control: on frame: right side

Type of control: pedal

6.2.2.2 Vehicles having no manual clutch control

6.2.2.2.1 Vehicles equipped with riding pedals must, and vehicles equipped with a platform or with footrests integrated into a platform which have a maximum design speed not exceeding 100 km/h may, conform to the requirement.

Position of control: on handlebars: left side forward

Type of control: hand lever

6.2.2.2.2 All other vehicles

Position of control: on frame: right side

Type of control: pedal

- 6.2.2.3 Nothing in the requirements set out in paragraphs 6.2.2.1. or 6.2.2.2.1. of this Regulation shall prohibit a moped equipped with riding pedals from, being equipped with a rear (wheel) brake operated by a back-peddalling device actuated by the riding pedals.
- 6.2.3 Combined service brake: Nothing in the requirements set out in paragraphs 6.2.1. or 6.2.2. of this Regulation shall prohibit a vehicle from being equipped with a combined service brake (see paragraph 2.12.).  
Position and type of control: as specified in paragraphs 6.2.1. and 6.2.2.
- 6.2.4 Parking brake: No special requirement.  
Type of control: hand lever or pedal
- 6.3 Transmission
- 6.3.1 Clutch: operating control  
Position of control: on handlebars: left side forward  
Type of control: hand lever  
Note: The above-mentioned requirement shall not prohibit, as a device for operating the clutch, the use of a combined foot lever control for both clutch operation and gear selection.
- 6.3.2 Gear selection control
- 6.3.2.1 In the case of vehicles equipped with a gear selection control operated independently of the clutch operating control  
Position of control: on frame: left side  
Type of control: foot lever or rocker arm
- 6.3.2.1.1 Movement of the foot lever or the forward part of the rocker arm in an upward direction shall progressively, select gears giving an increased forward speed and conversely for the selection of gears giving a reduced speed. A separate, positive "neutral" position shall be provided.
- 6.3.2.2 In the case of vehicles equipped with a gear selection control operated in conjunction with the clutch operating control:  
Position of control: on handlebars: left  
Type of control: rotating handgrip on handlebars.
- 6.3.2.2.1 Rotation of the handgrip anticlockwise shall, progressively, select gears giving an increased forward speed and conversely for the selection of gears giving a reduced speed. A separate, positive "neutral" position shall be provided.

6.4 Lighting and signaling controls

6.4.1 Audible Warning Device

6.4.1.1 In the case of vehicles equipped with a gear selection control operated independently of the clutch operating control:

Position of control: on handlebars: left side

Type of control: button

6.4.1.2 In the case of vehicle equipped with a gear selection control operated in conjunction with the clutch operating control:

Position of control: on handlebars: right side

Type of control: button

6.4.2 Lighting

6.4.2.1 Light control switch

In the case of a rotary switch, operation of the switch in a clockwise direction shall engage, progressively, the vehicle's position lights and then the vehicle's main lights. This shall not prevent the inclusion of additional switch positions provided that they are clearly indicated. The light control switch may be combined with the ignition desired.

6.4.2.2 Driving Beam/Passing Beam Switch

6.4.2.2.1 In the case of vehicle equipped with a gear selection control operated independently of the clutch operating control:

Position of control: on handlebars: left side

6.4.2.2.2 In the case of vehicles equipped with a gear selection control operated inconjunction with the clutch operating control:

Position of control: on handlebars: right side

6.4.2.3 Optical Warning Device The control for this device shall be adjacent to the Driving Beam/Passing Beam Switch or shall be an additional function of the latter.

6.4.3 Direction indicators switch

Position of control: on handlebars

The control shall be so designed that, when viewed from the rider's seat operation of the left hand portion, or movement to the left, of the control actuates the left side indicators and vice versa for the right side indicators.

The control shall be clearly marked in such a manner as to indicate the side of the vehicle on which the control actuates the indicators.



- 6.5            Fuel supply controls
- 6.5.1        Cold starting device The control shall be so placed as to be reasonably and conveniently accessible to the rider.
- 6.5.2        Manual fuel shut-off control The control shall have separate positive positions for "OFF", "ON" and "RESERVE" (where a reserve supply is provided).  
The control shall be in the ON position when it is in the direction downstream of the flow of fuel from the tank to the engine: in the OFF position when it is in a direction perpendicular to the flow of fuel, and in the RESERVE position (where applicable) when it is in the direction upstream of the flow of fuel.
- 6.5.2.1      Where a machine is so equipped the rider must be able to switch to the reserve fuel supply when in the seated position.
- 7            MODIFICATIONS OF THE VEHICLE TYPE
- 7.1        Every modification of the vehicle type shall be notified to the administrative department which approved the vehicle type. The department may then either:
- 7.1.1       consider that the modifications made are unlikely to have an appreciable adverse effect and that, in any case, the vehicle still complies with the requirements; or
- 7.1.2       require a further test report from the technical service responsible for conducting the tests.
- 7.2        Confirmation or refusal of approval, specifying the alterations, shall be communicated by the procedure specified in paragraph 4.3. above to the Parties to the Agreement applying this Regulation.
- 8            CONFORMITY OF PRODUCTION
- 8.1        Every vehicle bearing an approval mark as prescribed under this Regulation shall conform to the vehicle type approved, particularly as regards the driver-operated controls.
- 8.2        In order to verify conformity as prescribed in paragraph 8.1. above, a sufficient number of random checks shall be made on serially-manufactured vehicles bearing the approval mark required by this Regulation.
- 9            PENALTIES FOR NON-CONFORMITY OF PRODUCTION
- 9.1        The approval granted in respect of a vehicle type pursuant to this Regulation may be withdrawn if the requirements laid down in paragraph 8.1. above are not complied with or if the vehicle or vehicles taken fail to pass the tests prescribed in paragraph 8.2. above.

9.2 If a Party to the Agreement applying this Regulation withdraws an approval it has previously granted, it shall forthwith so notify the other Contracting Parties applying this Regulation, by means of a copy of the approval form bearing at the end, in large letters, the signed and dated annotation "APPROVAL WITHDRAWN".

10 PRODUCTION DEFINITELY DISCONTINUED

If the holder of the approval completely ceases to manufacture a type of vehicle approved in accordance with this Regulation, he shall so inform the authority which granted the approval. Upon receiving the relevant communication that authority shall inform thereof the other Parties to the Agreement applying this Regulation by means of a copy of the approval form bearing at the end, in large letters, the signed and dated annotation "PRODUCTION DISCONTINUED".

11 NAMES AND ADDRESSES OF TECHNICAL SERVICES RESPONSIBLE FOR CONDUCTING APPROVAL TESTS, AND OF ADMINISTRATIVE DEPARTMENTS

The Parties to the Agreement applying this Regulation shall communicate to the United Nations Secretariat the names and addresses of the technical services responsible for conducting approval tests and of the administrative departments which grant approval and to which forms certifying approval or refusal or withdrawal of approval, issued in other countries, are to be sent.

12 TRANSITIONAL PROVISIONS

The use of symbols specified in annex 4 to this Regulation becomes mandatory as from 1 July 1986.

Annex 1

(Maximum format: A4 (210 x 297 mm))

Name of administration
---------------------------



Communication concerning the approval (or refusal or withdrawal of approval or production definitely discontinued) of a vehicle type with regard to driver-operated controls pursuant to Regulation No. 60.

Approval No.....

1. Trade name or mark of the vehicle .....
2. Vehicle type .....
3. Manufacturer's name and address.....
4. If applicable, name and address of manufacturer's representative .....
5. Brief description of the vehicle as regards the driver-operated controls  
.....  
.....
6. Vehicle submitted for approval on .....
7. Technical service responsible for conducting approval inspection .....
8. Date of report issued by that service.....
9. Number of report issued by that service .....
10. Approval granted/refused <sup>1/</sup> .....
11. Position of approval mark on the vehicle .....
12. Place.....
13. Date.....
14. Signature .....
15. The following documents, bearing the approval number shown above, are annexed to this communication:

... drawings, diagrams and layout plans of the driver-operated controls and of the parts of the vehicle considered to be of importance for the purposes of this Regulation

---

<sup>1/</sup> Strike out what does not apply.

**លេខ. 2354—2550**

**ECE Regulation No. 60**

**00 series of amendments**

Rev. 1/Add. 59

Annex 2

ARRANGEMENTS OF APPROVAL MARKS

Model A

(see paragraph 4.4 of this Regulation)

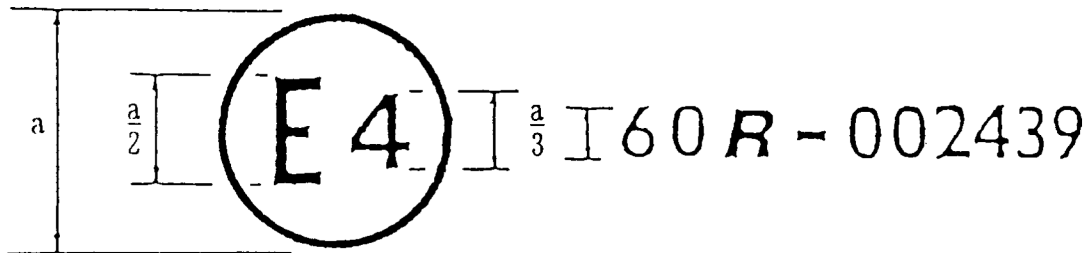

a= 8 mm min.

The above approval mark affixed to a vehicle shows that the vehicle type concerned has, with regard to the driver-operated controls, been approved in the Netherlands (E 4) pursuant to Regulation No. 60 under approval number 002439. The approval-number indicates that the approval was granted in accordance with the requirements of Regulation No. 60 in its original form.

Model B

(See paragraph 4.5 of this Regulation)

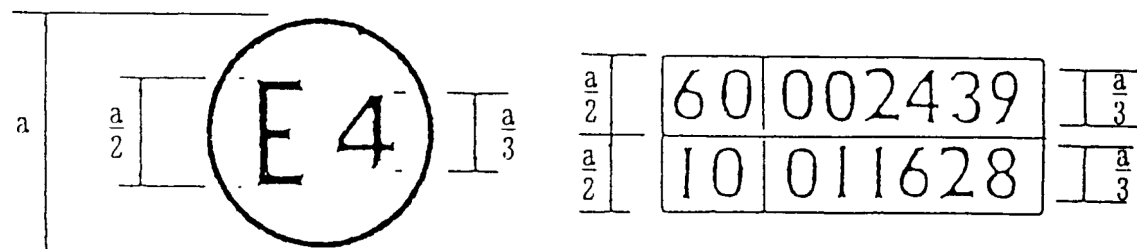

a= 8 mm min.

The above approval mark affixed to a vehicle shows that the vehicle type concerned has been approved in the Netherlands (E 4) pursuant to Regulations Nos. 60 and 10. 1/

The approval numbers indicate that, at the dates when the respective approvals were given, Regulation No.60 had not been modified, and Regulation No. 10 already included the 01 series of amendments.

---

1/ The latter number is given as an example only.

**លេខ. 2354—2550**

**ECE Regulation No. 60**

**00 series of amendments**

Rev. 1/Add. 59

Annex 3

SPECIAL PROVISIONS RELATING TO LEVERS

1. Part one: Hand Levers
  - 1.1 The maximum dimension between the forward face of the hand lever and the rearward face of the handgrip shall not exceed 120 mm measured perpendicularly to the axis of the handgrip at any point between the mid-point and the end thereof nearest the fulcrum of the hand lever (see figure 1(a)). In the case of vehicles equipped with a gear selection control operated in conjunction with the clutch operating control, the maximum dimension shall not exceed 135 mm.
  - 1.2 This dimension may increase beyond the mid-point of the handgrip and towards the open end of the hand lever.
  - 1.3 The minimum dimension (clearance) between the rearward face of the hand lever and the forward face of the handgrip shall not be less than 45 mm at any point between the outer end and the mid-point of the handgrip(see figure 1(b)).
  - 1.4 This dimension may decrease beyond the mid-point of the handgrip and towards the fulcrum but must in no case be less than 25 mm.
  - 1.5 The outer end of the hand lever shall not project beyond the outer end of the handgrip by more than 30 mm when the hand lever is in its position of maximum compression(see figure 1(c)).
2. Part two: Foot Levers, Rocker Arms and Pedalls
  - 2.1 Foot Levers
    - 2.1.1 The maximum dimension between the rearward face of the spur of the foot lever and the rearward face of the corresponding footrest shall not exceed 200 mm at any point of the spur of the foot lever (see figure 2).
    - 2.1.2 The minimum dimension (clearance) between the rearward face of the spur of the foot lever and the forward face of the corresponding footrest shall not be less than 105 mm at any point on the spur of the foot lever(see figure 2).
    - 2.1.3 In case footrests are adjustable such dimensions shall be measured at the normal points of adjustment provided for the footrest, as stated in the instructions given by the manufacturer to the owner/user of the vehicle (the "Owner's Manual") and with the foot lever in the position prescribed by the manufacturer.

2.2 Rocker Arms

2.2.1 2.2.1. The dimension (K) between the rearward part of the pad, or the rearward face of the spur, situated at the front of the rocker arm and the rearward face of the footrest shall not be more 200 mm nor less than 60 mm (see figure 3).

2.2.2 The dimension (L) between the forward part of the pad, or the forward face of the spur, situated at the rear of the rocker arm and the rearward face of the footrest shall not be more than 100 mm nor less than 50 mm (see figure 3).

2.2.3 In case footrests are adjustable such dimensions shall be measured at the normal points of adjustment provided for the footrest, as stated in the Owner's Manual, and with the rocker arm in the position prescribed by the manufacturer

2.3 Pedals

2.3.1 Vehicles equipped with footrests

2.3.1.1 The maximum dimension between the rearward part of the pad of the pedal and the rearward face of the corresponding footrest shall not exceed 170 mm at any point (see figure 4)

2.3.1.2 The minimum dimension (clearance) between the rearward part of the pad of the pedal and the forward face of the corresponding footrest shall not be less than 50 mm at any point (see figure 4).

2.3.1.3 In case footrests are adjustable such dimensions shall be measured at the normal points of adjustment provided for the footrest, as stated in the Owner's Manual, and with the pedal in the position prescribed by the manufacturer.

2.3.2 Vehicles equipped with platforms.

2.3.2.1 The maximum dimension between the surface of the platform and the highest point of the pad of the pedal, measured perpendicularly to the surface of the platform adjacent to the pedal, shall not exceed 105 mm (see figure 5)

2.3.2.2 The extreme outer edge of the pad of the pedal shall not project more than 25 mm beyond the outer edge of the platform (see figure 5).



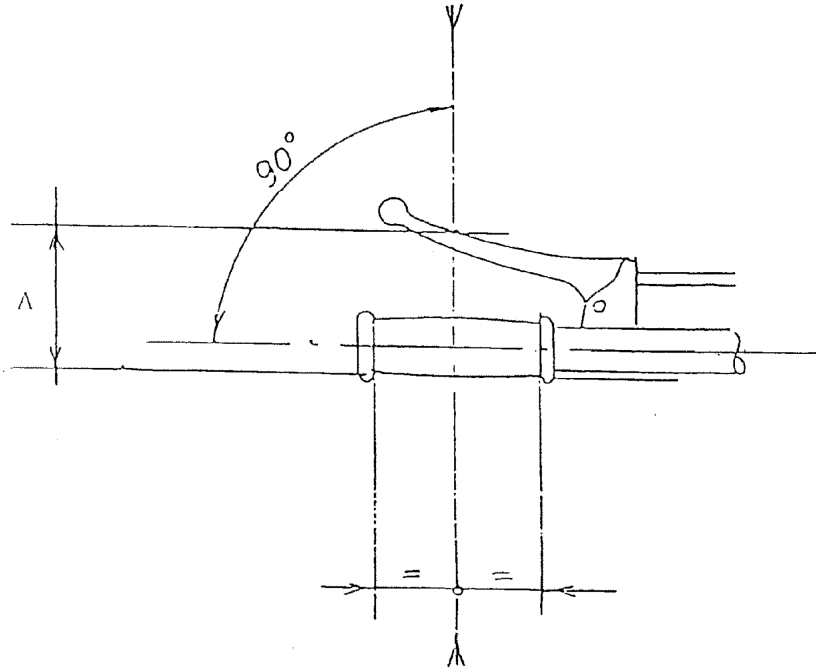

$A \leq 120\text{mm}$

**Figure 1(a)**

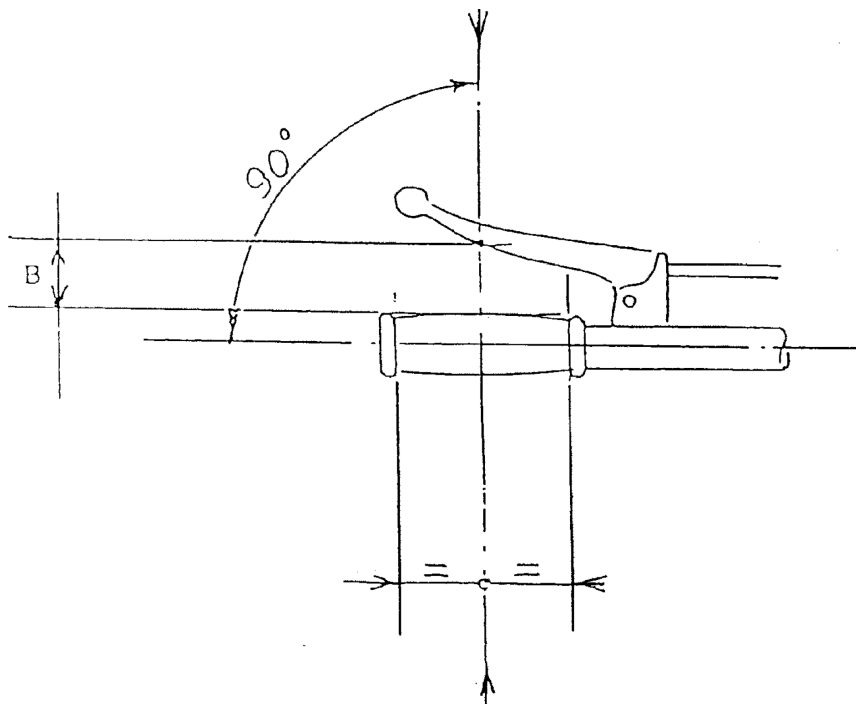

$B \geq 45\text{mm}$

**Figure 1(b)**

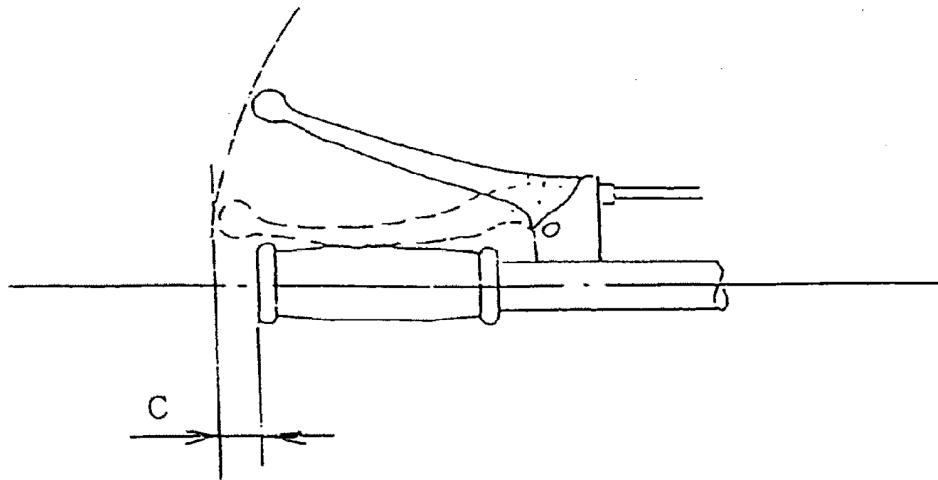

$C \leq 30 \text{ mm}$

**Figure 1(c)**

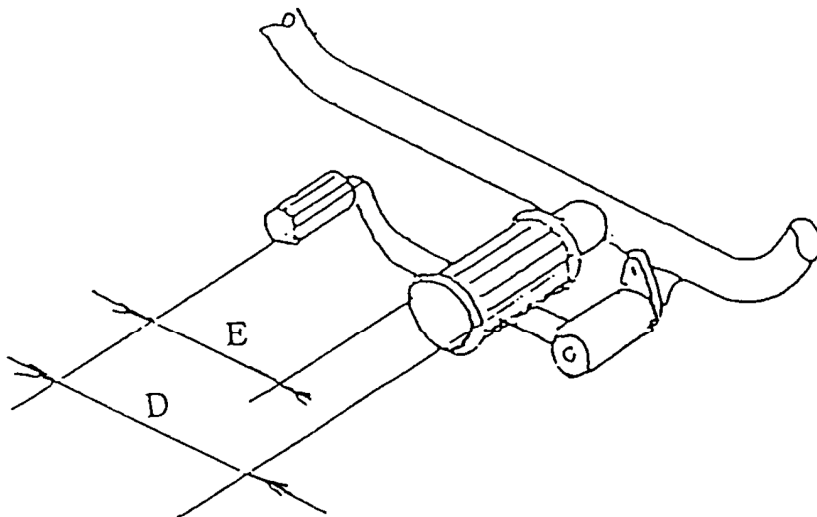

$D \leq 200 \text{ mm}$   
 $E \geq 105 \text{ mm}$

**Figure 2**

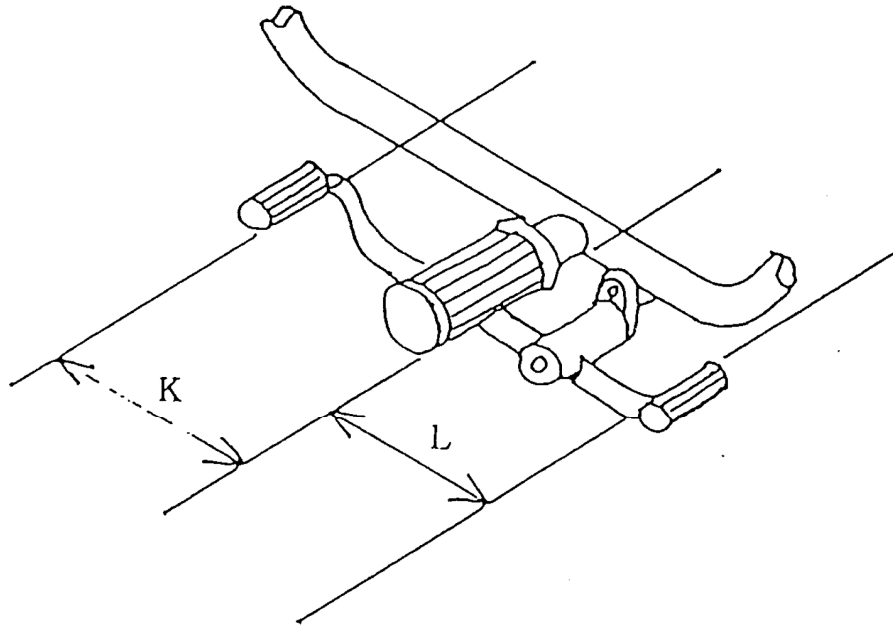

$$60 \text{ mm} \leq K \leq 200 \text{ mm}$$
$$50 \text{ mm} \leq L \leq 100 \text{ mm}$$

**Figure 3**

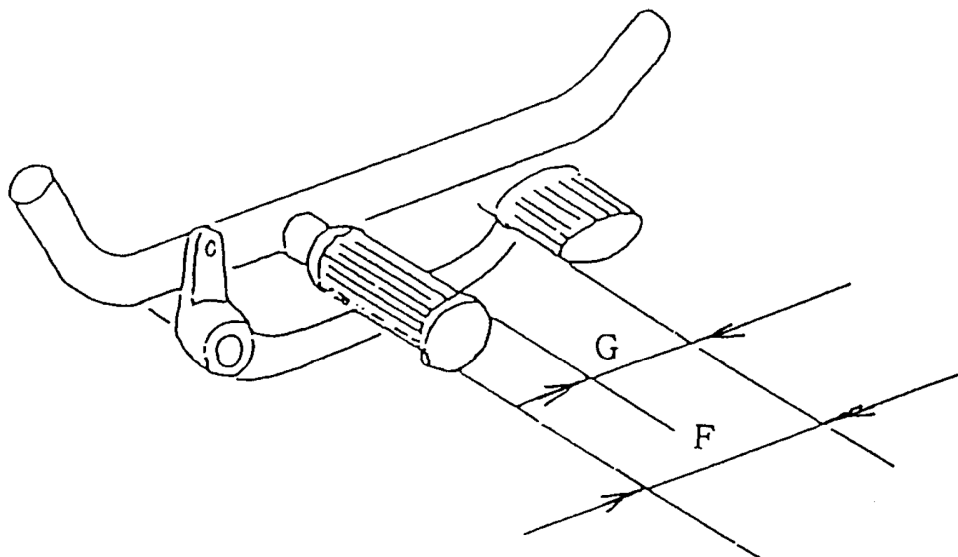

$$F \leq 170 \text{ mm}$$
$$G \geq 50 \text{ mm}$$

**Figure 4**

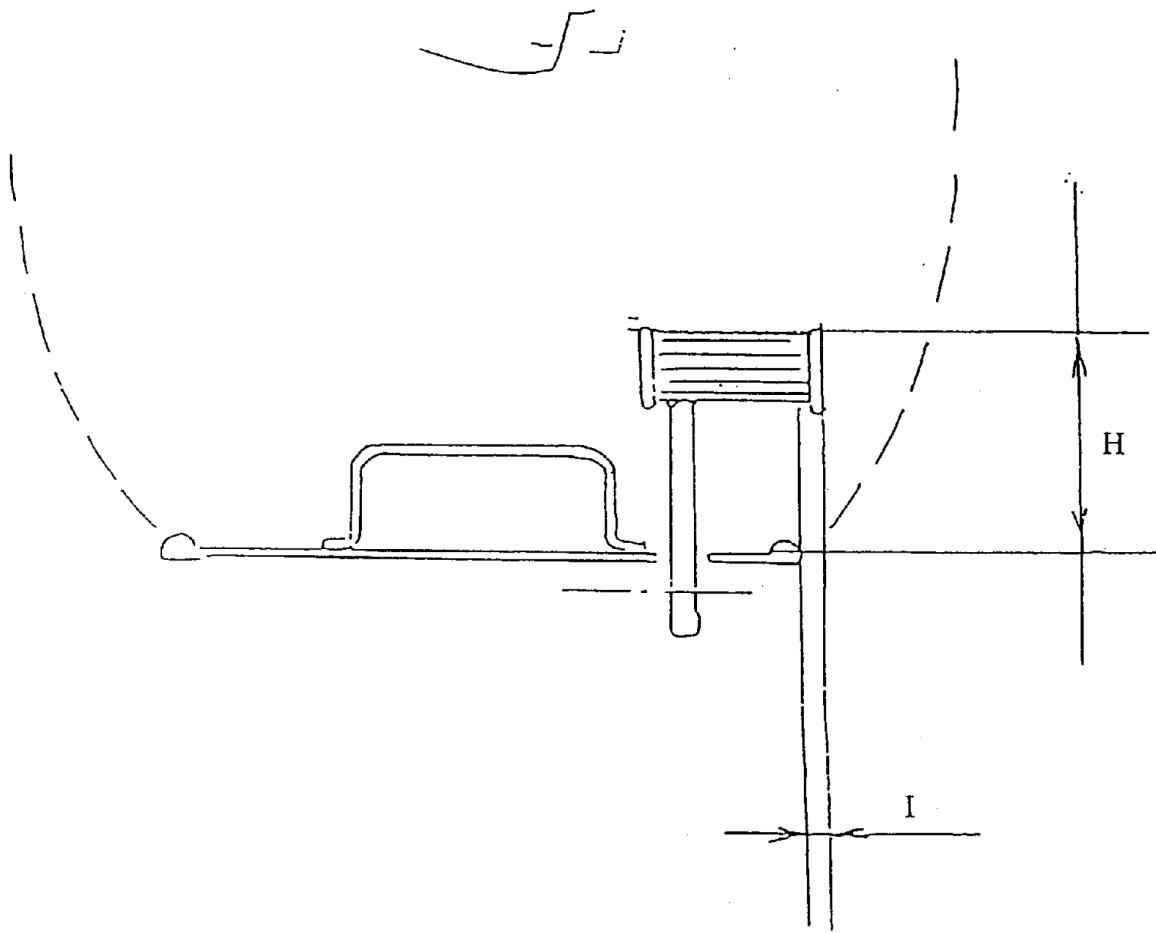

$$H \leq 105 \text{ mm}$$

$$I \leq 25 \text{ mm}$$

**Figure 5**

Annex 4

CONTROLS, TELL-TALES AND INDICATORS FOR WHICH, WHEN FITTED  
IDENTIFICATION IS MANDATORY, AND SYMBOLS TO BE USED FOR  
THAT PURPOSE 1/

1. This annex specifies the symbols, i.e., conventional signs, used to identify certain, controls, indicators and tell-tales on a motor cycle or a moped and to facilitate their usage. It also indicates the colours of possible optical tell-tales which warn the driver of the operation or malfunctioning of the devices and equipment connected to the corresponding controls.
2. This annex is applicable to those controls which, when used, are fitted on the instrument panel or in the immediate vicinity of the motor cycle or the moped driver. This definition of application does not signify the mandatory presence of each and every control listed in this annex.
3. The symbols must be such that, when viewed by the driver, from the seated position, they are recognizable as shown in paragraph 5 below.
4. The symbols shall stand out clearly against the background, being either light on a dark background or dark on a light background.
5. The symbol must be placed on, or adjacent to, the control or tell-tale to be identified. Where this is not possible, the symbol and the control or tell-tale must be joined by a continuous line as short as possible.
6. If, in a symbol, a motor cycle/(a moped) or parts of a motor cycle/(a moped) are shown in a side view, a motor cycle/(a moped) driving from right to left shall be assumed.
7. Focused light shall be represented by parallel rays and diffuse light by divergent rays.
8. When the following colours are used on the optical tell-tales, they shall have the meaning indicated below:

Red	: Danger
Yellow (Amber)	: Caution
Green	: Safe

(Blue shall be used only for the headlamp driving beam tell-tale.)

---

<sup>1/</sup> In conformity with the International Standards ISO 6727 - 1981 and 4129-1978.

In order to ensure correct graphic presentation and observance of the exact proportions, the symbols are reproduced in accordance with the ISO grid system (see also appendix to this annex).

**№00. 2354—2550**  
**ECE Regulation No. 60**  
**00 series of amendments**

Rev.1/Add.59

Annex 4

page 2

9. Designation and illustration  
of the symbols

Figure 1

Headlamp beam control

Driving beam

Colour of tell-tale light: blue

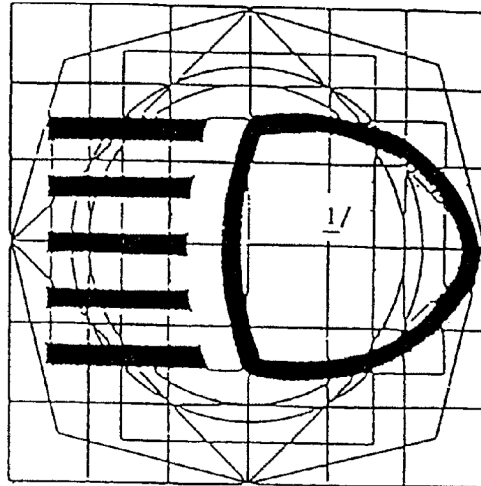

Figure 2

Headlamp beam control

Passing beam

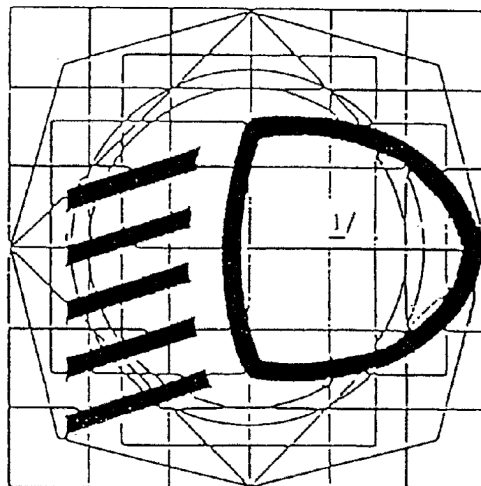

Figure 3

Turn signal

Colour of tell-tale light: green

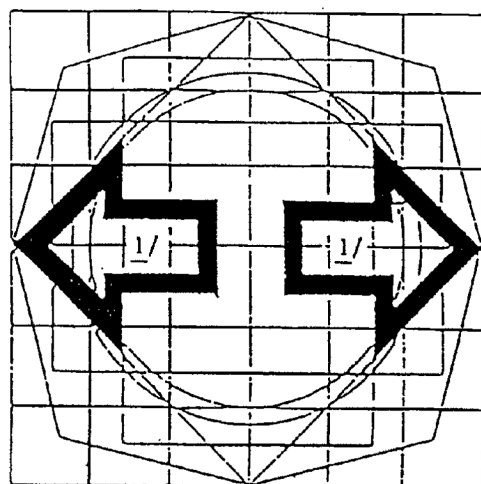

Figure 4  
Hazard warning (alternatives)  
Colour of tell-tale light: red  
or  
Simultaneous operation of both  
arrows of figure 3

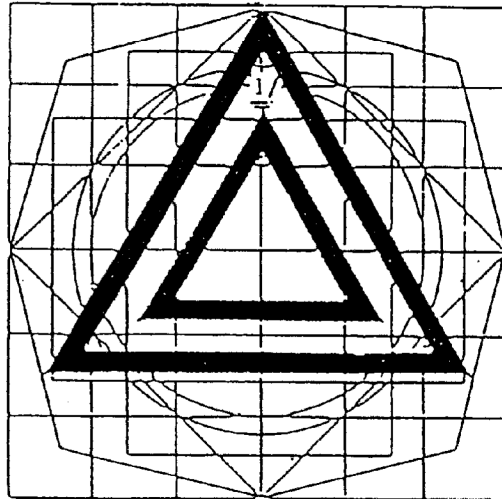

Figure 5  
Manual choke  
Colour of tell-tale light: amber

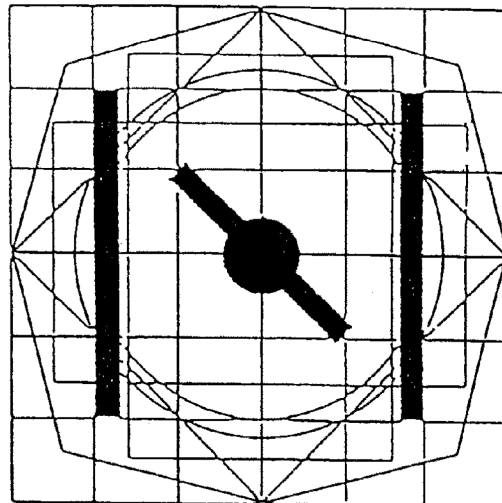

Figure 6  
Horn

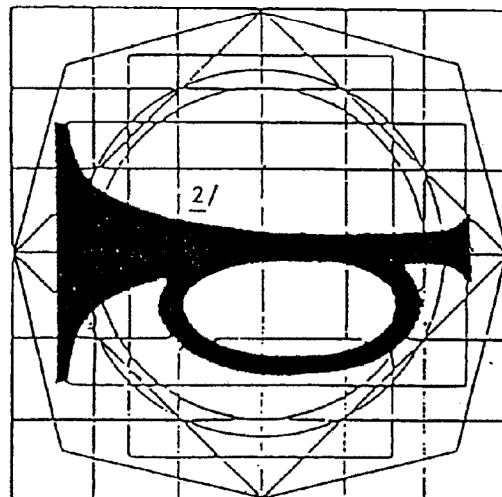

Figure 7

Fuel

Colour of tell-tale light: amber

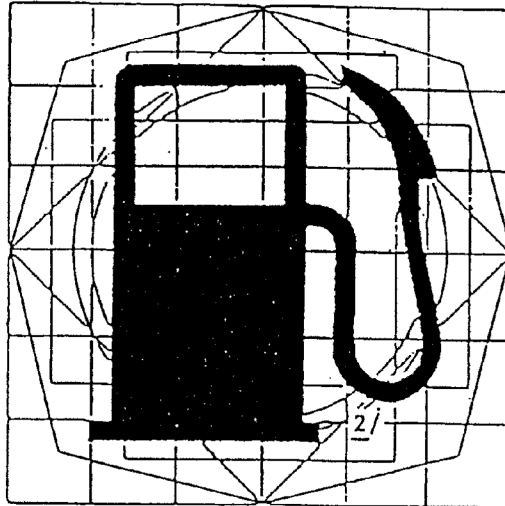

Figure 8

Engine coolant temperature

Colour of tell-tale light: red

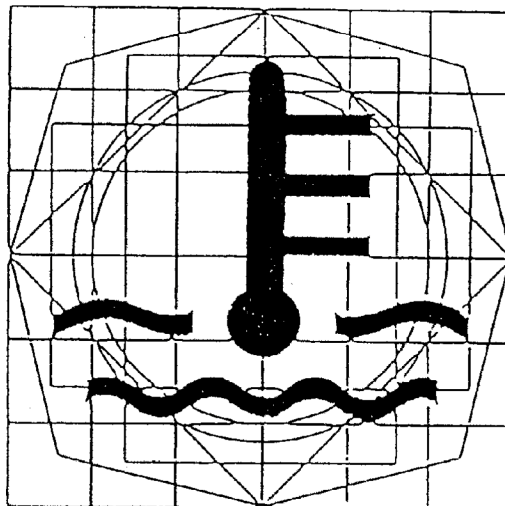

Figure 8

Engine coolant temperature

Colour of tell-tale light: red

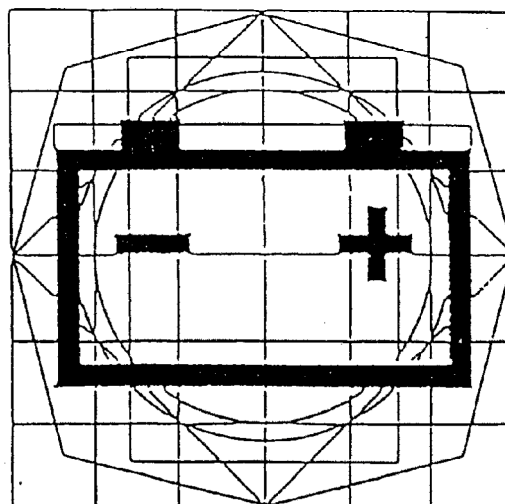



Figure 10  
Engine oil  
Colour of tell-tale light: red

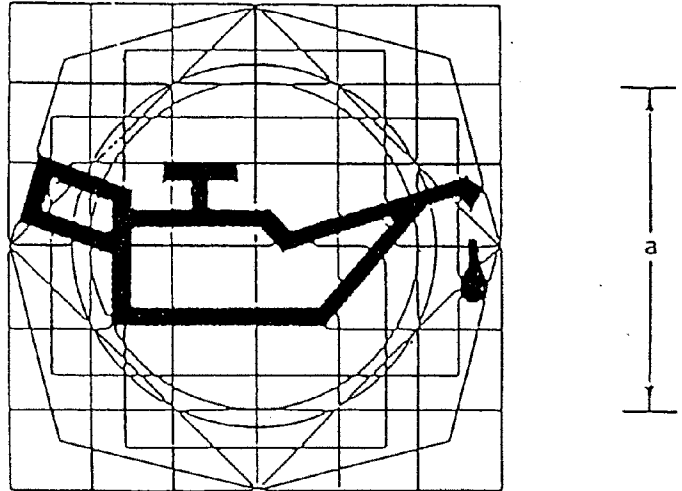

Figure 11  
Front fog light 3/  
Colour of tell-tale light: green

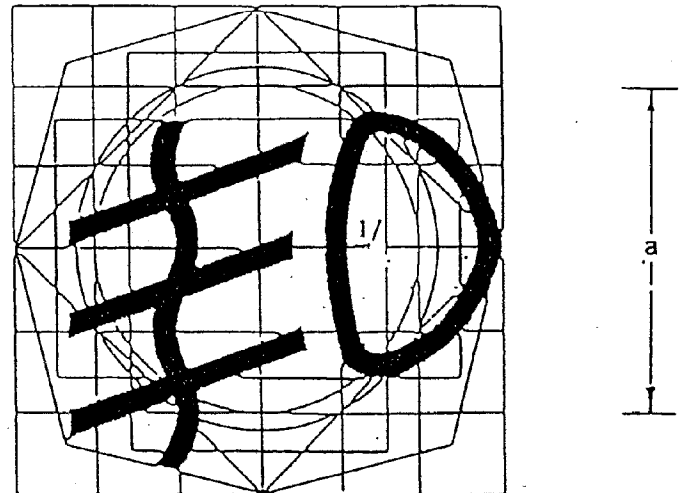

Figure 12  
Rear fog light 3/  
Colour of tell-tale light: amber

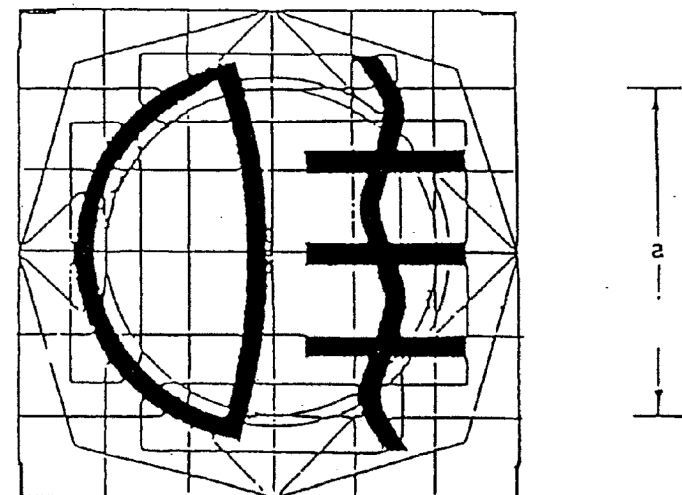

Figure 13  
Fuel tank shut off valve  
- position "off"

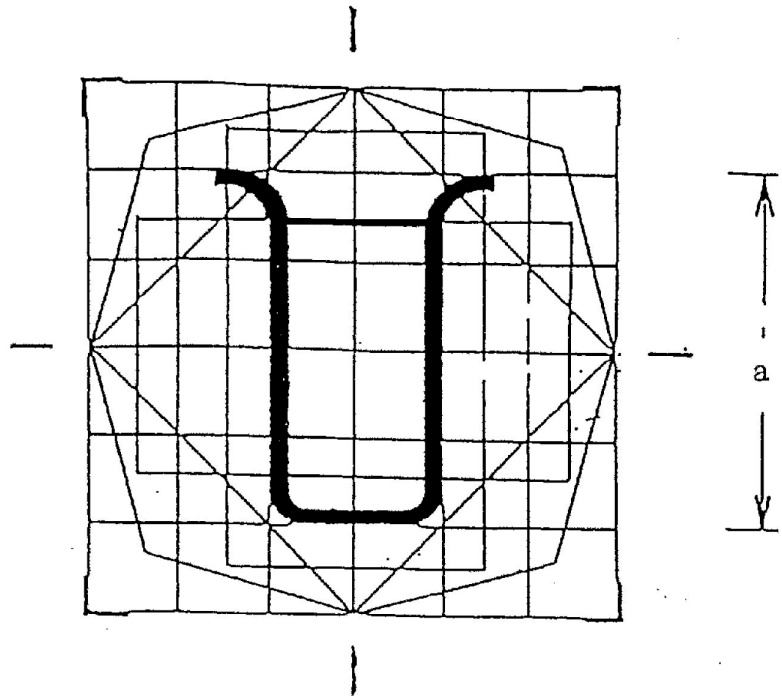

Figure 14  
Fuel tank shut off valve  
- position "reserve"

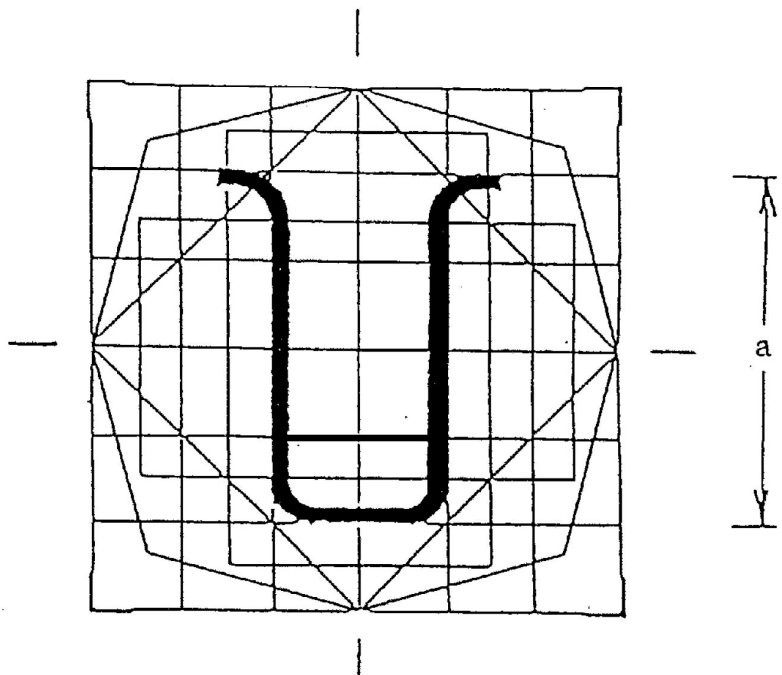

Figure 14  
Fuel tank shut off valve  
- position "reserve"

Figures 15A, B

Ignition control or  
supplemental engine stop

Figure 15A - position "off"

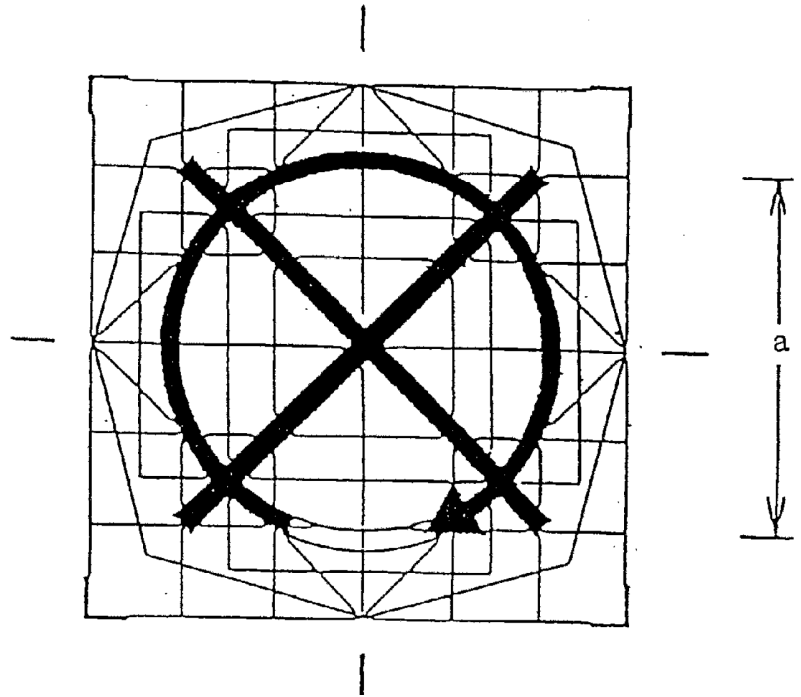
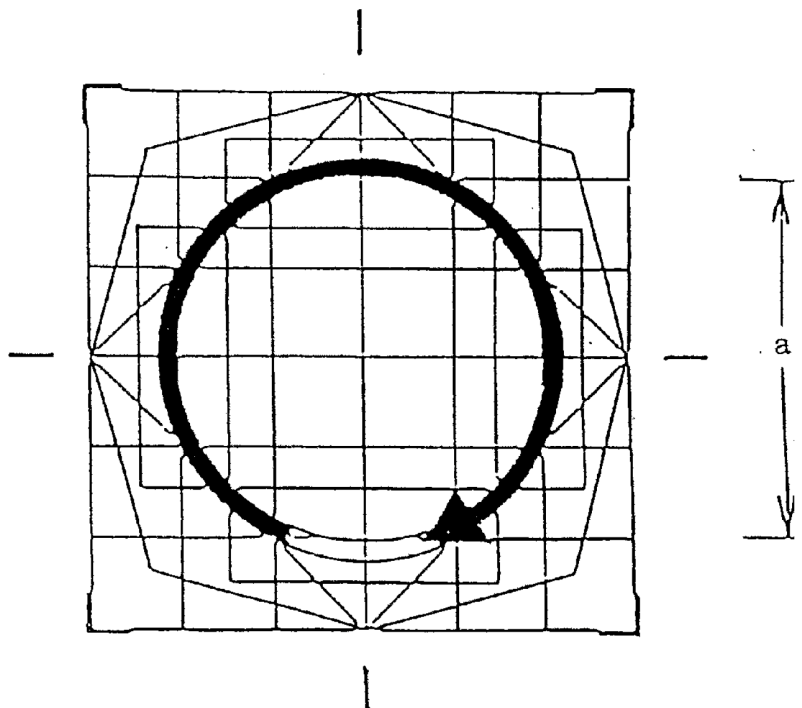

Figure 15 - position "run"



**№00. 2354—2550**  
**ECE Regulation No. 60**  
**00 series of amendments**

Rev.1/Add.59

Annex 4

page 8

Figures 16A, B, C

Lighting switch (may be  
combined with ignition control)

Figure 16A

Position light

Colour of tell-tale light:  
green

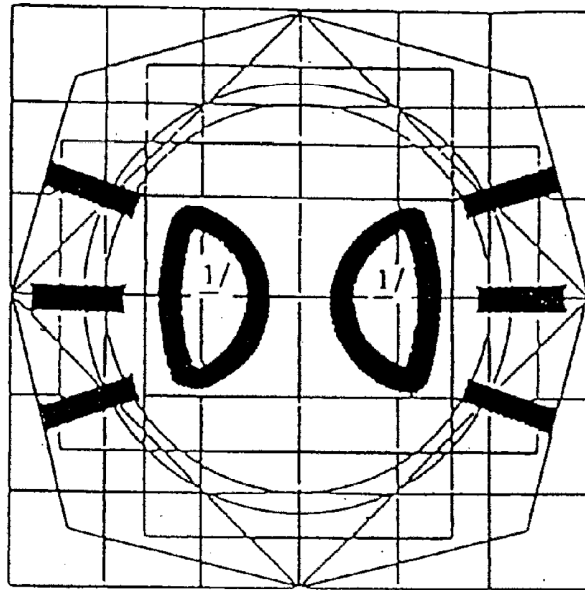

Figure 16B

Master lamp switch

Colour of tell-tale light:  
green

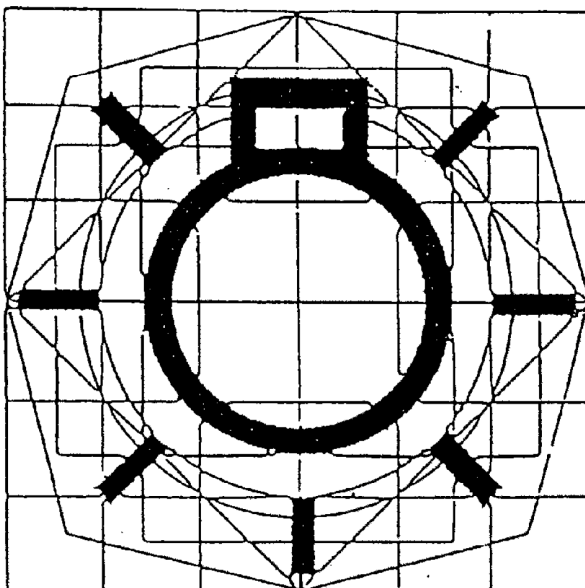

Figure 16C  
Parking light

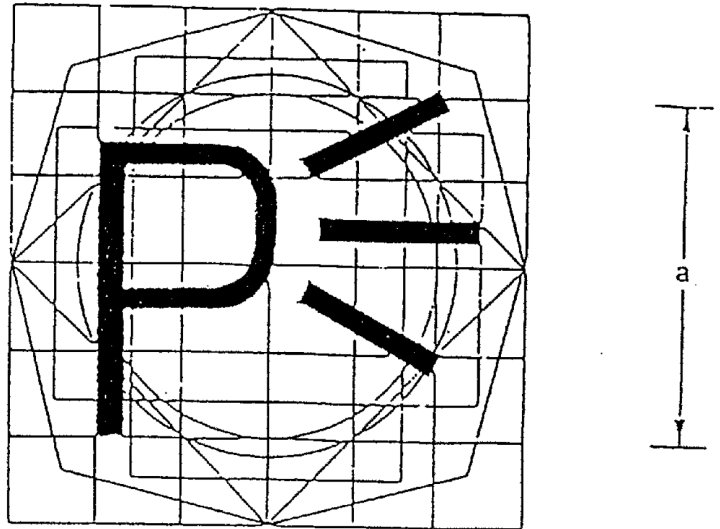
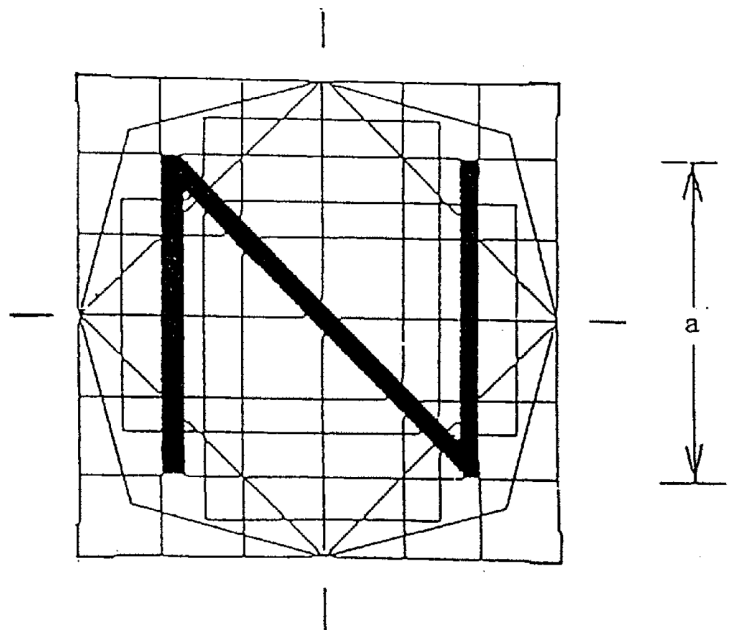

Figure 17  
Neutral indicator  
Colour of tell-tale light: green



លេខ. 2354—2550  
ECE Regulation No. 60  
00 series of amendments

Rev.1/Add.59

Annex 4

page 10

Figure 18  
Electric starter

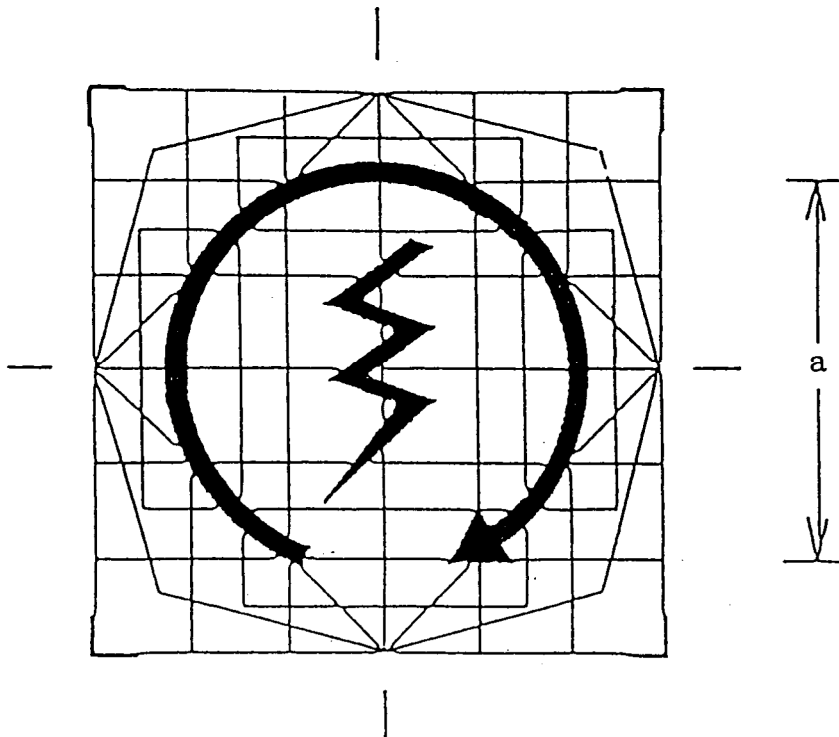

Notes

1/The interior of the symbol may be entirely in a dark colour.

2/The dark part of this symbol may be replaced by its outline, in which case the portion shown here as white must be entirely in a dark colour.

3/if one control is used for both front and rear fog lights, the symbol used shall be the one designated "front fog light".

Annex 4 - Appendix

CONSTRUCTION OF THE BASIC PATTERN FOR THE SYMBOLS SHOWN IN ANNEX 4

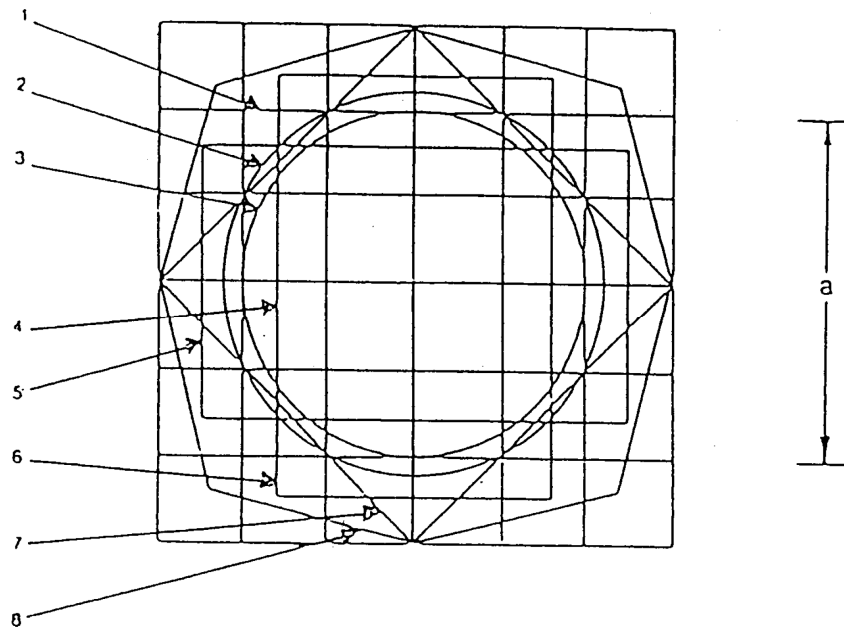

Figure 1  
Basic pattern

The basic pattern comprises:

1. A basic square of side 50 mm; this dimension is equal to the nominal dimension, 'a', of the basic pattern;
2. A basic circle of 56 mm diameter having approximately the same area as the basic square (1);
3. A second circle of 50 mm diameter, being the inscribed circle of the basic square (1);
4. A second square whose corners touch the basic circle (2) and whose sides are parallel to those of the basic square (1);
5. and 6. Two rectangles having the same area as the basic square (1); they are mutually perpendicular, each being drawn to cross opposite sides of the basic square symmetrically;
7. A third square whose sides pass through the points of intersection of the basic square (1) and the basic circle (2) and are at an angle of 45 degrees , giving the largest horizontal and vertical dimensions of the basic pattern;
8. An irregular octagon, formed by lines at an angle of 30 degrees to the sides of the square (7).

The basic pattern is superimposed on a 12.5 mm grid which coincides with the basic square (1).

№ 2354—2550

**ECE Regulation No. 60**

**00 series of amendments**

Rev. 1/Add.59/Amend.1

page 2

Paragraph 4.4.1, footnote 1/, pertinent to this paragraph, amend to read:

"1/ 1 for Germany, ... 8 for the Czech Republic, ... 15 (vacant), ... 22 for the Russian Federation, 23 for Greece, 24 (vacant), 25 for Croatia, 26 for Slovenia, 27 for Slovakia, 28 for Belarus and 29 for Estonia. Subsequent ..."

Add a new paragraph 6.3.2.1.2 to read as follows:

"Movement of the foot-operated gear selection control in a forward or a rearward direction is also permitted. In this case, movement of the foot lever in a rearward direction shall progressively select gears giving an increased speed and conversely for the selection of gears giving a reduced speed. A separate, positive 'neutral' position shall be provided."

-----

GE.95-22660 (E)





№00. 2354—2550

**ECE Regulation No. 60**

**00 series of amendments**

Rev. 1/Add.59/Amend.2

page 2

Paragraph 6.2.2.2.1., amend to read:

"6.2.2.2.1. Vehicles equipped with riding pedals must, and vehicles equipped with a platform or with footrests integrated into a platform may, conform to the requirement.

Position of control: on handlebars: left side forward

Type of control: hand lever."

---



Paragraph 1., amend to read:

"1. SCOPE

This Regulation applies to vehicles of categories L<sub>1</sub> and L<sub>3</sub> 1/ with regard to driver operated controls.

1/ As defined in Annex 7 to the Consolidated Resolution on the Construction of Vehicles (R.E.3), (document TRANS/WP.29/78/Rev.1/Amend.2 as last amended by Amend.4)."

Paragraph 4.4.1., footnote 1/, renumber as footnote 2/ and amend to read:

"2/ 1 for Germany, 2 for France, 3 for Italy, 4 for the Netherlands, 5 for Sweden, 6 for Belgium, 7 for Hungary, 8 for the Czech Republic, 9 for Spain, 10 for Serbia and Montenegro, 11 for the United Kingdom, 12 for Austria, 13 for Luxembourg, 14 for Switzerland, 15 (vacant), 16 for Norway, 17 for Finland, 18 for Denmark, 19 for Romania, 20 for Poland, 21 for Portugal, 22 for the Russian Federation, 23 for Greece, 24 for Ireland, 25 for Croatia, 26 for Slovenia, 27 for Slovakia, 28 for Belarus, 29 for Estonia, 30 (vacant), 31 for Bosnia and Herzegovina, 32 for Latvia, 33 (vacant), 34 for Bulgaria, 35 (vacant), 36 for Lithuania, 37 for Turkey, 38 (vacant), 39 for Azerbaijan, 40 for The former Yugoslav Republic of Macedonia, 41 (vacant), 42 for the European Community (approvals are granted by its Member States using their respective ECE symbol), 43 for Japan, 44 (vacant), 45 for Australia, 46 for Ukraine, 47 for South Africa, 48 for New Zealand, 49 for Cyprus, 50 for Malta, 51 for the Republic of Korea, 52 for Malaysia and 53 for Thailand. Subsequent numbers shall be assigned ....."

-----