

มาตรฐานผลิตภัณฑ์อุตสาหกรรม

THAI INDUSTRIAL STANDARD

มอก. 2404 เล่ม 1–2551

IEC60320–1(2007–11)

# คู่มือต่อเครื่องใช้สำหรับใช้ในที่อยู่อาศัย และจุดประสงค์ทั่วไปที่คล้ายกัน

เล่ม 1 ข้อกำหนดทั่วไป

APPLIANCES COUPLERS FOR HOUSEHOLD AND SIMILAR GENERAL  
PURPOSES

PART 1 : GENERAL REQUIREMENTS

สำนักงานมาตรฐานผลิตภัณฑ์อุตสาหกรรม

กระทรวงอุตสาหกรรม

ICS 29.120.30

ISBN 978-974-292-940-4

มาตรฐานผลิตภัณฑ์อุตสาหกรรม  
คู่เต้าต่อเครื่องใช้สำหรับใช้ในที่อยู่อาศัย  
และจุดประสงค์ทั่วไปที่คล้ายกัน  
เล่ม 1 ข้อกำหนดทั่วไป

มอก. 2404 เล่ม 1— 2551  
IEC60320 —1(2007 —11)

สำนักงานมาตรฐานผลิตภัณฑ์อุตสาหกรรม  
กระทรวงอุตสาหกรรม ถนนพระรามที่ 6 กรุงเทพฯ 10400  
โทรศัพท์ 0 2202 3300

ประกาศในราชกิจจานุเบกษาฉบับประกาศและงานทั่วไปเล่ม 126 ตอนพิเศษ 141ง  
วันที่ 28 กันยายน พุทธศักราช 2552

คู่เต้าต่อเครื่องใช้สำหรับใช้ในที่อยู่อาศัยเป็นผลิตภัณฑ์ซึ่งใช้สำหรับการต่อเครื่องใช้ไฟฟ้าเข้ากับแหล่งจ่ายไฟฟ้าวิธีสำคัญวิธีหนึ่งและมีใช้กันอย่างแพร่หลาย การต่อดังกล่าวจำเป็นต้องมีความมั่นคงแข็งแรง มีมิติที่ถูกต้อง ได้มาตรฐาน จึงจะทำให้เกิดความปลอดภัย จึงกำหนดมาตรฐานผลิตภัณฑ์อุตสาหกรรมคู่เต้าต่อเครื่องใช้สำหรับใช้ในที่อยู่อาศัยและจุดประสงค์ทั่วไปที่คล้ายกัน เล่ม 1 ข้อกำหนดทั่วไป ขึ้น

มาตรฐานผลิตภัณฑ์อุตสาหกรรมนี้กำหนดขึ้นโดยรับ IEC 60320-1(2007-11) Appliance couplers for household and similar general purposes-Part 1: General requirements มาใช้ในระดับเหมือนกันทุกประการ (identical) โดยใช้ IEC ฉบับภาษาอังกฤษเป็นหลัก

มาตรฐานผลิตภัณฑ์อุตสาหกรรมนี้กำหนดขึ้นเพื่อใช้ในการอ้างอิง และเพื่อให้ทันกับความต้องการของผู้ใช้มาตรฐาน ซึ่งจะได้แปลเป็นภาษาไทยในโอกาสอันสมควรต่อไป หากมีข้อสงสัยโปรดติดต่อสอบถามสำนักงานมาตรฐานผลิตภัณฑ์อุตสาหกรรม

คณะกรรมการมาตรฐานผลิตภัณฑ์อุตสาหกรรมได้พิจารณามาตรฐานนี้แล้ว เห็นสมควรเสนอรัฐมนตรีประกาศตาม มาตรา 15 แห่งพระราชบัญญัติมาตรฐานผลิตภัณฑ์อุตสาหกรรม พ.ศ. 2511



## ประกาศกระทรวงอุตสาหกรรม

ฉบับที่ 4019 ( พ.ศ. 2552 )

ออกตามความในพระราชบัญญัติมาตรฐานผลิตภัณฑ์อุตสาหกรรม

พ.ศ. 2511

เรื่อง กำหนดมาตรฐานผลิตภัณฑ์อุตสาหกรรม

คู่เต้าต่อเครื่องใช้สำหรับใช้ในที่อยู่อาศัยและจุดประสงค์ทั่วไปที่คล้ายกัน

เล่ม 1 ข้อกำหนดทั่วไป

---

อาศัยอำนาจตามความในมาตรา 15 แห่งพระราชบัญญัติมาตรฐานผลิตภัณฑ์อุตสาหกรรม พ.ศ. 2511 รัฐมนตรีว่าการกระทรวงอุตสาหกรรมออกประกาศกำหนดมาตรฐานผลิตภัณฑ์อุตสาหกรรมคู่เต้าต่อเครื่องใช้สำหรับใช้ในที่อยู่อาศัยและจุดประสงค์ทั่วไปที่คล้ายกัน เล่ม 1 ข้อกำหนดทั่วไป มาตรฐานเลขที่ มอก.2404 เล่ม 1-2551 ไว้ ดังมีรายละเอียดต่อท้ายประกาศนี้

ประกาศ ณ วันที่ 12 พฤษภาคม พ.ศ. 2552

ชาญชัย ชัยรุ่งเรือง

รัฐมนตรีว่าการกระทรวงอุตสาหกรรม

# มาตรฐานผลิตภัณฑ์อุตสาหกรรม

## คู่เต้าต่อเครื่องใช้สำหรับใช้ในที่อยู่อาศัย

### และจุดประสงค์ทั่วไปที่คล้ายกัน

#### เล่ม 1 ข้อกำหนดทั่วไป

มาตรฐานผลิตภัณฑ์อุตสาหกรรมนี้กำหนดขึ้นโดยรับ IEC 60320-1(2007-11) Appliance couplers for household and similar general purposes-Part 1: General requirements มาใช้ในระดับริมาณเหมือนกันทุกประการ (identical) โดยใช้ IEC ฉบับภาษาอังกฤษเป็นหลัก

มาตรฐานผลิตภัณฑ์อุตสาหกรรมนี้ใช้กับคู่เต้าต่อเครื่องใช้สองขั้วสำหรับไฟฟ้ากระแสสลับเท่านั้น มีหรือไม่มีขั้วสัมผัสลงดิน ที่มีแรงดันไฟฟ้าที่กำหนดไม่เกิน 250 โวลต์ และกระแสไฟฟ้าที่กำหนดไม่เกิน 16 แอมแปร์ สำหรับใช้ในที่อยู่อาศัยและจุดประสงค์ทั่วไปที่คล้ายกัน และประสงค์ให้ใช้สำหรับต่อสายอ่อนป้อนกำลังไฟฟ้าเข้ากับเครื่องใช้ไฟฟ้าหรือบริภัณฑ์ไฟฟ้าอื่นสำหรับแหล่งจ่าย 50 เฮิร์ตซ์ หรือ 60 เฮิร์ตซ์

**หมายเหตุ 1** เต้าเสียบเครื่องใช้ที่รวมเป็นหน่วยเดียวกับเครื่องใช้หรือบริภัณฑ์อื่น อยู่ในขอบข่ายของมาตรฐานนี้ ข้อกำหนดเชิงมิติและทั่วไปของมาตรฐานนี้ใช้ได้กับเต้าเสียบดังกล่าว แต่การทดสอบบางรายการอาจใช้ไม่ได้

**หมายเหตุ 2** ข้อกำหนดสำหรับเต้ารับติดตั้งอยู่บนพื้นฐานของสมมุติฐานที่ว่าอุณหภูมิของขาเสียบของเต้าเสียบเครื่องใช้ที่สมมุติกันไม่เกิน

- 70 องศาเซลเซียส สำหรับภาวะเย็น
- 120 องศาเซลเซียส สำหรับภาวะร้อน
- 155 องศาเซลเซียส สำหรับร้อนอย่างยิ่ง

**หมายเหตุ 3** คู่เต้าต่อเครื่องใช้ที่เป็นไปตามมาตรฐานนี้เหมาะสำหรับใช้ที่อุณหภูมิโดยรอบไม่เกิน 25 องศาเซลเซียส แต่ในบางโอกาสอาจสูงถึง 35 องศาเซลเซียส

**หมายเหตุ 4** คู่เต้าต่อเครื่องใช้ที่เป็นไปตามแผ่นข้อมูลมาตรฐานในมาตรฐานนี้ประสงค์ให้ใช้สำหรับการต่อของบริภัณฑ์ที่ไม่มีการป้องกันความชื้นเป็นพิเศษ ถ้าคู่เต้าต่อเครื่องใช้ถูกใช้กับบริภัณฑ์ซึ่งอาจมีการทรุดของของเหลวในการใช้งานปกติ บริภัณฑ์ต้องจัดให้มีการป้องกันความชื้น

**หมายเหตุ 5** อาจต้องมีการสร้างพิเศษ

- ในสถานที่ซึ่งมีภาวะพิเศษ เช่น ในเรือ ยานพาหนะ และที่คล้ายกัน
- ในสถานที่อันตราย เช่น อาจเกิดการระเบิด

รายละเอียดให้เป็นไปตาม IEC 6320-1(2007-11)

## CONTENTS

FOREWORD .....	5
1 Scope .....	7
2 Normative references .....	7
3 Definitions .....	8
4 General requirements .....	11
5 General notes on tests .....	11
6 Standard ratings .....	12
7 Classification .....	13
8 Marking .....	13
9 Dimensions and compatibility .....	15
10 Protection against electric shock .....	18
11 Provision for earthing .....	19
12 Terminals and terminations .....	19
13 Construction .....	20
14 Moisture resistance .....	24
15 Insulation resistance and electric strength .....	25
16 Forces necessary to insert and to withdraw the connector .....	26
17 Operation of contacts .....	28
18 Resistance to heating of appliance couplers for hot conditions or very hot conditions .....	28
19 Breaking capacity .....	29
20 Normal operation .....	30
21 Temperature rise .....	31
22 Cords and their connection .....	31
23 Mechanical strength .....	36
24 Resistance to heat and ageing .....	39
25 Screws, current-carrying parts and connections .....	41
26 Creepage distances, clearances and distances through insulation .....	44
27 Resistance of insulating material to heat, fire and tracking .....	45
28 Resistance to rusting .....	48
29 Electromagnetic compatibility (EMC) requirements .....	48
Annex A (normative) Routine tests for factory wired appliance couplers related to safety (protection against electric shock and correct polarity) .....	112

Standard sheets C1 – C25 .....	49
Figure 1 – Survey of appliance couplers.....	75
Figure 1 – Survey of appliance couplers ( <i>concluded</i> ).....	76
Figure 2 – "GO" gauge for connectors to standard sheet C1 (see 9.1) .....	77
Figure 4 – "GO" gauge for connectors to standard sheet C5 (see 9.1) .....	78
Figure 5 – "GO" gauge for connectors to standard sheet C7 (see 9.1) .....	79
Figure 5A – "GO" gauge for side-entry connectors to standard sheet C7 (see 9.1).....	80
Figure 6 – "NOT GO" gauge for connectors to standard sheet C1 (see 9.4) .....	81
Figure 7 – "NOT-GO" gauge for connectors to standard sheets C1, C5 and C7 (see 9.4).....	82
Figure 8 – "NOT-GO" gauge for connectors to standard sheets C1 and C7 (see 9.4) .....	83
Figure 9 – "NOT-GO" gauge for appliance inlets to standard sheets C8, C8A and C8B (see 9.4) .....	84
Figure 9A – "GO" gauge for connectors to standard sheet C9 (see 9.1) .....	85
Figure 9B – "NOT-GO" gauge for connectors to standard sheet C9 (see 9.4).....	86
Figure 9C – "GO" gauge for appliance inlets to standard sheets C10 (see 9.1) .....	87
Figure 9F – "GO" gauge for connectors to standard sheet C13 (see 9.1) .....	88
Figure 9G – "NOT-GO" gauge for connectors to standard sheets C13 and C17 (see 9.4).....	89
Figure 9H – "GO" gauge for appliance inlets to standard sheets C14, C16 and C18 (see 9.1).....	90
Figure 9J – "GO" gauge for connectors to standard sheet C15 (see 9.1).....	91
Figure 9K – "GO" gauge for connectors to standard sheet C17 (see 9.1) .....	92
Figure 9L – "GO" gauge for connectors to standard sheet C19 (see 9.1) .....	93
Figure 9M – "GO" gauge for appliance inlets to standard sheets C20 and C24(see 9.1) .....	94
Figure 9N – "GO" gauge for connectors to standard sheet C21 (see 9.1) .....	95
Figure 9P – "GO" gauge for appliance inlets to standard sheet C22 (see 9.1) .....	96
Figure 9Q – "GO" gauge for connectors to standard sheet C23 (see 9.1).....	97
Figure 9R – "NOT-GO" gauge for connectors to standard sheets C13, C15 and C17 (see 9.4).....	98
Figure 9S – "GO" gauge for connectors to standard sheet C15A (see 9.1).....	99
Figure 9T – "GO" gauge for appliance inlets to standard sheet C16A (see 9.1) .....	100
Figure 10 – Standard test finger (see 10.1) .....	101
Figure 11 – Device for testing non-solid pins (see 13.4) .....	102
Figure 12 – Apparatus for checking the withdrawal force (see 16.2) .....	102
Figure 13 – Example of apparatus for heating test (see 18.2) .....	103
Figure 14 – VOID.....	103
Figure 15 – Circuit diagram for breaking capacity and normal operation tests (see clauses 19 and 20) .....	104
Figure 16 – Apparatus for testing the cord anchorage (see 22.3).....	104
Figure 17 – Apparatus for the flexing test (see 22.4) .....	105
Figure 18 – VOID.....	105
Figure 19 – Example of apparatus for pulling test (see 23.3) .....	106
Figure 20 – Example of apparatus for pressure test on shrouds (see 23.4) .....	106
Figure 21 – Impact-test apparatus (see 23.5) .....	107

Figure 22 – Blades for checking the resistance against deformation of the front part of the connector to standard sheet C7 (see 23.6) .....	107
Figure 23 – Ball-pressure apparatus (see 24.1.2) .....	108
Figure 24 – Apparatus for pressure test on connectors (see 24.1.3) .....	109
Figure 25 – VOID.....	109
Figure 26 – VOID.....	109
Figure 27 – Gauges for checking the distance from the engagement face of connectors to the point of first contact (see 9.1) .....	110
Figure 28 – Thread-forming tapping screw (see 3.19).....	111
Figure 29 – Thread-cutting tapping screw (see 3.20) .....	111
Figure 30 – Gauge for the verification of the minimum withdrawal force .....	111
Table 2 – Maximum diameters of the cords .....	25
Table 3 – Maximum and minimum withdrawal forces .....	26
Table 4 – Type and minimum nominal cross-sectional area of cords.....	32
Table 5 – Types of cord for the rewirable connector test.....	33
Table 6 – Type of cord and nominal cross-sectional area for rewirable connectors .....	34
Table 7 – Values for the lateral pulls applied.....	37
Table 8 – Torque applied for the tightening and loosening test .....	42
Table 9 – Minimum creepage distances and clearances through insulation.....	45



## INTERNATIONAL ELECTROTECHNICAL COMMISSION

**APPLIANCE COUPLERS FOR HOUSEHOLD  
AND SIMILAR GENERAL PURPOSES –****Part 1: General requirements**

## FOREWORD

- 1) The International Electrotechnical Commission (IEC) is a worldwide organization for standardization comprising all national electrotechnical committees (IEC National Committees). The object of IEC is to promote international co-operation on all questions concerning standardization in the electrical and electronic fields. To this end and in addition to other activities, IEC publishes International Standards, Technical Specifications, Technical Reports, Publicly Available Specifications (PAS) and Guides (hereafter referred to as "IEC Publication(s)"). Their preparation is entrusted to technical committees; any IEC National Committee interested in the subject dealt with may participate in this preparatory work. International, governmental and non-governmental organizations liaising with the IEC also participate in this preparation. IEC collaborates closely with the International Organization for Standardization (ISO) in accordance with conditions determined by agreement between the two organizations.
- 2) The formal decisions or agreements of IEC on technical matters express, as nearly as possible, an international consensus of opinion on the relevant subjects since each technical committee has representation from all interested IEC National Committees.
- 3) IEC Publications have the form of recommendations for international use and are accepted by IEC National Committees in that sense. While all reasonable efforts are made to ensure that the technical content of IEC Publications is accurate, IEC cannot be held responsible for the way in which they are used or for any misinterpretation by any end user.
- 4) In order to promote international uniformity, IEC National Committees undertake to apply IEC Publications transparently to the maximum extent possible in their national and regional publications. Any divergence between any IEC Publication and the corresponding national or regional publication shall be clearly indicated in the latter.
- 5) IEC provides no marking procedure to indicate its approval and cannot be rendered responsible for any equipment declared to be in conformity with an IEC Publication.
- 6) All users should ensure that they have the latest edition of this publication.
- 7) No liability shall attach to IEC or its directors, employees, servants or agents including individual experts and members of its technical committees and IEC National Committees for any personal injury, property damage or other damage of any nature whatsoever, whether direct or indirect, or for costs (including legal fees) and expenses arising out of the publication, use of, or reliance upon, this IEC Publication or any other IEC Publications.
- 8) Attention is drawn to the Normative references cited in this publication. Use of the referenced publications is indispensable for the correct application of this publication.
- 9) Attention is drawn to the possibility that some of the elements of this IEC Publication may be the subject of patent rights. IEC shall not be held responsible for identifying any or all such patent rights.

International Standard IEC 60320-1 has been prepared by subcommittee 23G: Appliance couplers, of IEC technical committee 23: Electrical accessories.

This consolidated version of IEC 60320-1 consists of the second edition (2001) [documents 23G/215/FDIS and 23G/218/RVD] and its amendment 1 (2007) [documents 23G/272/FDIS and 23G/274/RVD].

The technical content is therefore identical to the base edition and its amendment and has been prepared for user convenience.

It bears the edition number 2.1.

A vertical line in the margin shows where the base publication has been modified by amendment 1.

Annex A forms an integral part of this standard.

IEC 60320 consists of the following parts, under the general title: *Appliance couplers for household and similar general purposes*:

- Part 2-1: Sewing machine couplers
- Part 2-2: Interconnection couplers for household and similar equipment
- Part 2-3: Appliance couplers with a degree of protection higher than IPX0

The committee has decided that the contents of the base publication and its amendments will remain unchanged until the maintenance result date indicated on the IEC web site under "<http://webstore.iec.ch>" in the data related to the specific publication. At this date, the publication will be

- reconfirmed,
- withdrawn,
- replaced by a revised edition, or
- amended.

# APPLIANCE COUPLERS FOR HOUSEHOLD AND SIMILAR GENERAL PURPOSES –

## Part 1: General requirements

### 1 Scope

This part of IEC 60320 is applicable to two-pole appliance couplers for a.c. only, with or without earthing contact, with a rated voltage not exceeding 250 V and a rated current not exceeding 16 A, for household and similar general purposes and intended for the connection of a supply cord to electrical appliances or other electrical equipment for 50 Hz or 60 Hz supply.

NOTE 1 Appliance inlets integrated or incorporated in appliances or other equipment are within the scope of this standard. The dimensional and general requirements of this standard apply to such inlets, but certain tests may not be relevant.

NOTE 2 The requirements for connectors are based on the assumption that the temperature of the pins of the corresponding appliance inlets does not exceed

- 70 °C for connectors for cold conditions;
- 120 °C for connectors for hot conditions;
- 155 °C for connectors for very hot conditions.

NOTE 3 Appliance couplers complying with this standard are suitable for use at ambient temperatures not normally exceeding 25 °C, but occasionally reaching 35 °C.

NOTE 4 Appliance couplers complying with the standard sheets in this standard are intended for the connection of equipment having no special protection against moisture. If appliance couplers are used with equipment which may be subject to spillage of liquid in normal use then protection against moisture is to be provided by the equipment.

NOTE 5 Special constructions may be required

- in locations where special conditions prevail, for example, as in ships, vehicles and the like;
- in hazardous locations, for example, where explosions are liable to occur.

### 2 Normative references

The following referenced documents are indispensable for the application of this document. For dated references, only the edition cited applies. For undated references, the latest edition of the referenced document (including any amendments) applies.

IEC 60050(151):1978, *International Electrotechnical Vocabulary (IEV) – Chapter 151: Electrical and magnetic devices*

IEC 60068-2-32:1975, *Environmental testing – Part 2: Tests – Test Ed: Free fall*

IEC/TR 60083:1997, *Plugs and socket-outlets for domestic and similar general use standardized in member countries of IEC*

IEC 60112:1979, *Method for determining the comparative and the proof tracking indices of solid insulating materials under moist conditions*

IEC 60227 (all parts), *Polyvinyl chloride insulated cables of rated voltages up to and including 450/750 V*

IEC 60245 (all parts), *Rubber insulated cables – Rated voltages up to and including 450/750 V*

IEC 60695-2-10:2000, *Fire hazard testing – Part 2-10: Glowing/hot-wire based test methods – Glow-wire apparatus and common test procedure*

IEC 60695-2-11:2000, *Fire hazard testing – Part 2-11: Glowing/hot-wire based test methods – Glow-wire flammability test method for end-products*

IEC 60695-2-12:2000, *Fire hazard testing – Part 2-12: Glowing/hot-wire based test methods – Glow-wire flammability test method for materials*

IEC 60695-2-13:2000, *Fire hazard testing – Part 2-13: Glowing/hot-wire based test methods – Glow-wire ignitability test method for materials*

IEC 60730 (all parts), *Automatic electrical controls for household and similar use*

IEC 60999-1:1999, *Connecting devices – Electrical copper conductors – Safety requirements for screw-type and screwless-type clamping units – Part 1: General requirements and particular requirements for clamping units for conductors from 0,2 mm<sup>2</sup> up to 35 mm<sup>2</sup> (included)*

IEC 61058 (all parts), *Switches for appliances*

IEC 61140:1997, *Protection against electric shock – Common aspects for installation and equipment*

ISO 286-1:1988, *ISO system of limits and fits – Part 1: Bases of tolerances, deviations and fits*

ISO 1101:1983, *Technical drawings – Geometrical tolerancing – Tolerancing of form, orientation, location and run-out – Generalities, definitions, symbols, indications on drawings*

ISO 1456:1988, *Metallic coatings – Electrodeposited coatings of nickel plus chromium and of copper plus nickel plus chromium*

ISO 2081:1986, *Metallic coatings – Electroplated coatings of zinc on iron or steel*

ISO 2093:1986, *Electroplated coatings of tin – Specification and test methods*

### 3 Definitions

Where the terms "voltage" and "current" are used, they imply the r.m.s. values, unless otherwise specified.

For the purpose of this International Standard, the following definitions apply.

The term "**accessory**" is used as a general term covering connectors and/or appliance inlets (and, in some cases, plugs as well).

#### 3.1

##### **appliance coupler**

means enabling the connection and disconnection at will, of a cord to an appliance or other equipment. It consists of two parts: a connector and an appliance inlet

#### 3.2

##### **connector**

part of the appliance coupler integral with, or intended to be attached to, the cord connected to the supply

NOTE Only one cord is connected to the connector.

**3.3****appliance inlet**

part of the appliance coupler integrated or incorporated in the appliance or equipment or intended to be fixed to it

NOTE 1 An appliance inlet integrated in an appliance or equipment is an appliance inlet (the shroud and base of) which is formed by the housing of the appliance or equipment.

NOTE 2 An appliance inlet incorporated in an appliance or an equipment is a separate appliance inlet built in or fixed to an appliance or equipment.

**3.4****rewirable accessory**

accessory so constructed that the cord can be replaced

**3.5****non-rewirable accessory**

accessory so constructed that it forms a constructional unit with the cord which is assembled by the manufacturer of the accessory. This unit shall be such that

- the cord cannot be separated from the accessory without making this permanently useless, and
- the accessory cannot be opened by hand or by using a general purpose tool, for example a screwdriver, as intended

NOTE An accessory is considered to be permanently useless when for re-assembling the accessory, parts or materials other than the original are to be used.

**3.6****cord set**

assembly consisting of one cord fitted with one non-rewirable plug and one non-rewirable connector, intended for the connection of an electrical appliance or equipment to the electrical supply

**3.7****base of a pin**

part of the pin where it protrudes from the engagement face

**3.8****retaining device**

mechanical arrangement which holds a connector in proper engagement with a corresponding appliance inlet and prevents its unintentional withdrawal

**3.9****rated voltage**

voltage assigned to the accessory by the manufacturer

**3.10****rated current**

current assigned to the accessory by the manufacturer

**3.11****terminal**

part to which a conductor is attached, providing a re-usable connection

**3.12****termination**

part to which a conductor is permanently attached

**3.13****screw-type terminal**

terminal for the connection and subsequent disconnection of a conductor, the connection being made, directly or indirectly by, means of screws or nuts of any kind

**3.14****pillar terminal**

screw-type terminal in which the conductor is inserted into a hole or cavity, where it is clamped under the shank of a screw. The clamping pressure may be applied directly by the shank of the screw or through an intermediate clamping plate to which pressure is applied by the shank of the screw

**3.15****screw terminal**

screw-type terminal in which the conductor is clamped under the head of a screw. The clamping pressure may be applied directly by the head of the screw or through an intermediate part, such as a washer, clamping plate or anti-spread device

**3.16****stud terminal**

screw-type terminal in which the conductor is clamped under a nut. The clamping pressure may be applied directly by a suitably shaped nut or through an intermediate part, such as a washer, clamping plate or anti-spread device

**3.17****screwless terminal**

connecting terminal for the connection and subsequent disconnection of a conductor, the connection being made, directly or indirectly, by means of springs, wedges, eccentrics, cones, etc.

**3.18****tapping screw**

screw manufactured from a material having a higher resistance to deformation when applied by rotary insertion into a hole in a material having a lower resistance to deformation

NOTE The screw is made with a tapered thread, the taper being applied to the core diameter of the thread at the end section of the screw. The thread produced by application of the screw is formed securely only after sufficient revolutions have been made to exceed the number of threads on the tapered section.

**3.19****thread-forming tapping screw**

tapping screw having an uninterrupted thread. It is not a function of this thread to remove material from the hole

NOTE An example of a thread-forming tapping screw is shown in figure 28.

**3.20****thread-cutting tapping screw**

tapping screw having an interrupted thread. It is a function of this thread to remove material from the hole

NOTE An example of a thread-cutting tapping screw is shown in figure 29.

**3.21****type test**

test of one or more devices made to a certain design to show that the design meets certain requirements

[IEV 151-04-15]

**3.22****routine test**

test to which each individual device is subjected during and/or after manufacture to ascertain whether it complies with certain criteria

[IEV 151-04-16]

**4 General requirements**

Appliance couplers shall be so designed and constructed that in normal use their performance is reliable and without danger to the user or surroundings.

In general, compliance is checked by carrying out all the tests specified.

NOTE It is to be understood that appliance couplers are to be capable of meeting all the relevant requirements and tests specified in this standard.

**5 General notes on tests**

**5.1** Tests shall be made to prove compliance with the requirements laid down in this standard, where applicable.

Tests are as follows:

- type tests shall be made on representative samples of each accessory;
- routine tests shall be conducted by the manufacturer and made on each accessory manufactured to this standard, where applicable.

Subclauses 5.2 to 5.7 are applicable to type tests and 5.8 to routine tests.

**5.2** Unless otherwise specified, the specimens are tested as delivered and under normal conditions of use, at an ambient temperature of  $20\text{ °C} \pm 5\text{ °C}$ ; they are tested with a.c. at 50 Hz or 60 Hz.

Non-rewirable connectors, other than those forming part of a cord set, shall be submitted with a cord at least 1 m long.

**5.3** Unless otherwise specified, the tests are carried out in the order of the clauses.

**5.4** Unless otherwise specified, connectors and appliance inlets are tested in conjunction with an appropriate appliance inlet or connector, complying with this standard.

**5.5** For appliance inlets, three specimens are subjected to the tests specified.

For connectors, nine specimens (11 if of elastomeric or thermoplastic material) are required:

- set 1 of three specimens is subjected to the tests specified, with the exception of those of clauses 14, 15, 16, 19, 20 and 21 and of 22.4 and 24.2;
- set 2 of three specimens is subjected to the tests of clauses 14, 15, 16, 19, 20 and 21 (including the repetition of the tests of clause 16);
- set 3 of three specimens is subjected to the test of 22.4;
- set 4 of two specimens of elastomeric or thermoplastic material is subjected to the test of 24.2 (including the preconditioning according to clause 16).

For non-rewirable connectors with indicators, three additional specimens with one pole of the indicator disconnected are required for the tests of clause 15.

**5.6** Appliance inlets integrated or incorporated in an appliance or equipment are tested under the conditions of use of the equipment, the number of specimens then being the same as the number of specimens of equipment required according to the relevant standard for the equipment.

**5.7** Connectors and appliance inlets are considered not to comply with this standard if there are more failures than that of one specimen in one of the tests. If one specimen fails in a test, that test and those preceding which may have influenced the result of that test are repeated on another set of specimens of the number specified in 5.5, all of which shall then comply with the repeated tests.

In general, only the test which caused the failure need be repeated unless

- a) a failure occurs to one of the three specimens of set 2 specified in 5.5, when tested in accordance with clauses 19, 20 or 21, in which case the tests required by 5.5 for set 2 are repeated from clause 16 onwards; or
- b) a failure occurs to one of the three specimens of set 1 specified in 5.5, when tested in accordance with clauses 22 or 23 (except 22.4), in which case the tests required by 5.5 for set 1 are repeated from clause 18 onwards.

The applicant may submit, together with the first set of specimens, the additional set which may be wanted should one specimen fail. The testing station will then, without further request, test the additional specimens and will only reject if a further failure occurs. If the additional set of specimens is not submitted at the same time, a failure of one specimen will entail a rejection.

**5.8** Routine tests are specified in annex A.

## **6 Standard ratings**

**6.1** The standard rated voltage is 250 V.

**6.2** Standard rated currents are 0,2 A, 2,5 A, 6 A, 10 A and 16 A, as specified in 9.1.

Compliance with the requirements of 6.1 and 6.2 is checked by visual inspection of the marking.



## 7 Classification

7.1 Appliance couplers are classified:

7.1.1 According to maximum pin temperature at the base of the pins of the corresponding appliance inlet:

- appliance couplers for cold conditions (pin temperature not exceeding 70 °C);
- appliance couplers for hot conditions (pin temperature not exceeding 120 °C);
- appliance couplers for very hot conditions (pin temperature not exceeding 155 °C).

7.1.2 According to the type of equipment to be connected:

- appliance couplers for class I equipment;
- appliance couplers for class II equipment.

NOTE For a description of the classes, see IEC 61140.

7.2 Connectors are, moreover, classified according to the method of connecting the cord:

- rewirable connectors;
- non-rewirable connectors.

NOTE 1 Figure 1 shows the various types of appliance couplers standardized and their application.

NOTE 2 0,2 A appliance couplers are intended only for the connection of small hand-held class II equipment, if allowed by the relevant standard for the equipment.

NOTE 3 Appliance inlets for cold conditions are not intended to be used with heating appliances having external metal parts, the temperature rise of which may, under normal operating conditions, exceed 75 K and which might be touched in normal use by the cord.

NOTE 4 Appliance couplers for hot conditions may also be used under cold conditions; appliance couplers for very hot conditions may also be used under cold or hot conditions.

## 8 Marking

8.1 Connectors shall be marked with:

- rated current in amperes, except for 0,2 A connectors;
- rated voltage in volts;
- symbol for nature of supply;
- name, trade mark or identification mark of the maker or responsible vendor;
- type reference;
- the marking as specified in Subclause 7.5 of IEC 60999-1 to identify the type of conductors suitable for screwless terminals.



NOTE The type reference may be a catalogue number.

8.2 Appliance inlets other than those integrated or incorporated in an appliance or equipment shall be marked with the name, trade mark or identification mark of the maker or responsible vendor and a type reference, the latter being not visible after the appliance inlet is correctly mounted or a connector is in engagement. The marking of 0,2 A and 2,5 A appliance inlets may be visible, provided that there can be no doubt with regard to the marking of the appliance itself.

NOTE The type reference may be a catalogue number.

**8.3** Connectors and appliance inlets for class II equipment shall not be marked with the symbol for class II construction.

**8.4** When symbols are used, they shall be as follows:

amperes	A
volts	V
alternating current	~
earth	 or 

NOTE Preferably the symbol with a circle should be used.

For the marking of rated current and rated voltage, figures may be used alone, the figure for rated current being placed before or above that for rated voltage and separated from the latter by a line. The symbol for nature of supply shall be placed next to the marking for rated current and rated voltage.

NOTE 1 The marking for current, voltage and nature of supply may accordingly be as follows:

$$10 \text{ A } 250 \text{ V } \sim \text{ or } 10/250 \sim \text{ or } \frac{10}{250} \sim \text{ or } \left( \frac{10}{250} \right) \sim$$

NOTE 2 Lines formed by the construction of the tool are not considered as part of the marking.



**8.5** The marking specified in 8.1 shall be easily discernible when the connector is wired ready for use.

NOTE The term "ready for use" does not imply that the connector is in engagement with an appliance inlet.

**8.6** In non-reversible connectors, the contact positions shall be established by looking at the engagement face of the connectors as shown in figure 1 and their disposition shall be as follows:

earthing contact:	upper central position;
line contact:	lower right-hand position;
neutral contact:	lower left-hand position.

In rewirable, non-reversible connectors, terminals shall be indicated as follows:

earthing terminal:	the symbol  or 
neutral terminal:	the letter N

In non-rewirable, non-reversible connectors, no marking of contacts is necessary, but cores shall be connected as specified in 22.1.

Appliance inlets, other than those integrated or incorporated in an appliance or equipment, for use with connectors according to this subclause, shall have terminal markings to correspond with this subclause.

The marking symbol or letters shall not be placed on screws, removable washers or other removable parts.

NOTE The requirement concerning the marking of terminals and the connection of conductors has been introduced to take into account those countries which already require a polarized supply system and with regard to a possible future introduction of a unified plug and socket-outlet system, which will be to a great extent a polarized system. It is recommended that this requirement be taken into account already now in countries which at present have no polarized plug and socket-outlet system.

Rewirable connectors shall be supplied with the following instructions:

- a) a diagram illustrating the method of connection of the conductors, in particular the (excess) length of the earthing conductor and the operation of the cord anchorage;
- b) a full-scale diagram showing the length of sleeving and insulation to be stripped back;
- c) the sizes and types of suitable cords.

NOTE 1 It is essential that the connection of the earthing conductor is shown in an instructive way, preferably with sketches.

NOTE 2 These instructions need not follow connectors supplied directly to an equipment manufacturer.

**8.7** The markings required by the standard shall be easily legible and durable.

**8.8** Compliance with the requirements of 8.1 to 8.7 is checked by inspection and by rubbing the marking by hand for 15 s with a piece of cloth soaked with water and again for 15 s with a piece of cloth soaked with petroleum spirit.

After this test and all non-destructive tests of the standard, the marking shall remain legible. It shall not be easily possible to remove labels and they shall not show curling.

NOTE 1 The type reference may be marked in paint or ink, if necessary, protected by varnish.

NOTE 2 The petroleum spirit used should consist of a solvent hexane with a content of aromatics of maximum 0,1 volume percentage, a kauri-butanol value of 29, an initial boiling point of approximately 65 °C, a dry-point of approximately 69 °C and a density of approximately 0,68 g/cm<sup>3</sup>.

## 9 Dimensions and compatibility

**9.1** Appliance couplers shall comply with the appropriate standard sheets as specified below, except as permitted by 9.6:

0,2 A 250 V appliance coupler for class II equipment and cold conditions:

- connector ..... sheet C1
- appliance inlet ..... sheet C2

2,5 A 250 V appliance coupler for class I equipment and cold conditions:

- connector ..... sheet C5
- appliance inlet ..... sheet C6

2,5 A 250 V appliance coupler for class II equipment and cold conditions:

- connector ..... sheet C7
- appliance inlet, standard type ..... sheets C8 and C8A
- appliance inlet, for alternative connection of the equipment to two different mains voltages ..... sheet C8B

6 A 250 V appliance coupler for class II equipment and cold conditions:

- connector ..... sheet C9
- appliance inlet ..... sheet C10

10 A 250 V appliance coupler for class I equipment and cold conditions:

- connector ..... sheet C13
- appliance inlet..... sheet C14

10 A 250 V appliance coupler for class I equipment and hot conditions:

- connector ..... sheet C15
- appliance inlet..... sheet C16

10 A 250 V appliance coupler for class I equipment and very hot conditions:

- connector ..... sheet C15A
- appliance inlet..... sheet C16A

10 A 250 V appliance coupler for class II equipment and cold conditions:

- connector ..... sheet C17
- appliance inlet..... sheet C18

16 A 250 V appliance coupler for class I equipment and cold conditions:

- connector ..... sheet C19
- appliance inlet..... sheet C20

16 A 250 V appliance coupler for class I equipment and very hot conditions:

- connector ..... sheet C21
- appliance inlet..... sheet C22

16 A 250 V appliance coupler for class II equipment and cold conditions:

- connector ..... sheet C23
- appliance inlet..... sheet C24

Dimensions are checked by means of gauges or by measurement. In case of doubt, gauges shall be used.

The test is carried out at an ambient temperature of  $25\text{ °C} \pm 5\text{ °C}$ , both the accessories and the gauges being at this temperature.

The gauges to be used are shown in

- figure 2 for 0,2 A connectors;
- figures 4, 5 and 5A for 2,5 A connectors;
- figures 9A to 9T for other connectors and appliance inlets.

The distance from the engagement face of connectors to the point of first contact of socket contacts is checked by means of the relevant gauge shown in figure 27.

NOTE Dimensions for the fixing of appliance inlets are under consideration.

**9.2** Provision, if any, for retaining the connector in the appliance inlet shall comply with standard sheet C25.

Compliance is checked by measurement.

**9.3** It shall not be possible to make single-pole connections between connectors and appliance inlets.

Appliance inlets shall not allow improper connections with portable socket-outlets complying with IEC 60083.

Connectors shall not allow improper connections with plugs complying with IEC 60083.

Compliance is checked by manual test.

NOTE 1 "Improper connections" include single-pole connection and other connections which do not comply with the requirements concerning protection against electric shock.

NOTE 2 Conformity to the standard sheets ensures compliance with these requirements.

**9.4** It shall not be possible to engage

- connectors for class II equipment with appliance inlets for other equipment;
- connectors for cold conditions with appliance inlets for hot conditions or very hot conditions;
- connectors for hot conditions with appliance inlets for very hot conditions;
- connectors with appliance inlets having a higher rated current than the connector.

Compliance is checked by inspection, by manual test and by means of the gauges shown in figures 6 to 9.

For 6 A, 10 A and 16 A connectors and appliance inlets, compliance is checked by means of the gauges shown in figures 9A to 9T, as applicable.

The test is carried out at an ambient temperature of  $35\text{ °C} \pm 2\text{ °C}$ , both the accessories and the gauges being at this temperature.

NOTE Conformity to the standard sheets ensures compliance with the requirements, other than those verified by means of the gauges shown in figures 6 to 9.

**9.5** If appliance inlets are arranged countersunk in the outer surface of equipment, and if this surface is curved or inclined with respect to the axis of the appliance inlet, the arrangement shall be such that, under any circumstances, the pin ends do not protrude beyond the limiting surface of the shroud.

Compliance is checked by connecting all pins, including the earthing pin, if any, together with one pole of a contact indicator, the other pole being connected to a metal straight-edge ruler, having a width wider than the largest inside dimension of the appliance inlet, which is placed in all possible directions over the opening of the shroud. The ruler shall not come into contact with the pin ends.

NOTE 1 For 10 A and 16 A appliance inlets for class II equipment, the test shall be carried out with a simulated earthing pin.

NOTE 2 An electrical indicator with a voltage between 40 V and 50 V is used to show contact with the relevant part.

**9.6** Non-standardized appliance couplers which do not refer to the dimensions specified in the standard sheets are acceptable, but only if they provide a technical advantage and do not adversely affect the purpose and safety of appliance couplers complying with the standard sheets, especially with regard to interchangeability and non-interchangeability.

Non-standardized appliance couplers, however, shall comply with all other requirements of this standard as far as they reasonably apply.

NOTE A "technical advantage" may be claimed if, for example, a connector of a given rating has to be enlarged to accommodate components such as switches or thermostats, or if, for some reason, it is necessary to prevent the use of a standard connector with the normal length or type of cord.

Small deviations from the dimensions as specified in the standard sheets, which give the impression of a standardized coupler and lead to confusion with standardized appliance couplers, are not allowed.

Changes which adversely affect the contact-making ability are not allowed.

It must not be possible to engage such a non-standard accessory with a complementary accessory complying with the standard sheets, but of a different current rating. Neither shall it be possible to engage it with a standardized complementary accessory of the same rating if, by so doing, live parts are rendered any more accessible than is the case with a standardized appliance coupler of the same rating or if the combination of non-standardized accessory and standard complementary accessory fails to comply with the requirements of this standard other than the dimensions in the standard sheets.

It shall not be possible within a given system for a connector and associated appliance inlet to make improper connections other than the intended position or partial connections causing deformation which can impair the further use of the appliance.

Compliance is checked by manual test.

## **10 Protection against electric shock**

**10.1** Appliance couplers shall be so designed that live parts of appliance inlets are not accessible when the connector is in partial or complete engagement.

Connectors shall be so designed that live parts, and the earthing contact and parts connected thereto, are not accessible when the connector is properly assembled and wired as in normal use.

Compliance is checked by inspection and, if necessary, by a test with the standard test finger shown in figure 10. This finger is applied in every possible position, an electrical indicator being used to show contact with the relevant parts. For connectors with enclosures or bodies of elastomeric or thermoplastic material, the standard test finger is applied for 30 s with a force of 20 N at all points where yielding of the insulating material could impair the safety of the connector; this test is made at an ambient temperature of  $35\text{ °C} \pm 2\text{ °C}$ .

NOTE 1 An electrical indicator with a voltage between 40 V and 50 V is used to show contact with the relevant part.

NOTE 2 Conformity to the standard sheets ensures compliance with the requirements so far as the inaccessibility of contact members during insertion of a connector into an appliance inlet is concerned.

**10.2** It shall not be possible to make connection between a pin of an appliance inlet and a contact of a connector as long as any of the pins is accessible.

Compliance is checked by manual test and by the test of 10.1.

NOTE Conformity to the standard sheets ensures compliance with this requirement.

**10.3** It shall not be possible to remove parts preventing access to live parts without the aid of a tool.

The means for fixing these parts shall be insulated from live parts.

Bushes, if any, in the entry holes for the pins shall be adequately fixed and it shall not be possible to remove them without dismantling the connector.

Compliance is checked by inspection and by manual test.

**10.4** External parts of connectors, with the exception of assembly screws and the like, shall be of insulating material. The shroud and the base of appliance inlets without earthing contact and those of 2,5 A appliance inlets with earthing contact, shall be of insulating material.

Compliance is checked by inspection.

NOTE 1 The suitability of the insulating material is checked during the insulation tests of clause 15.

NOTE 2 Lacquer or enamel is not considered to be insulating material for the purpose of 10.1 to 10.4.

## **11 Provision for earthing**

**11.1** Earthing terminals shall comply with the requirements of clause 12.

Compliance is checked by inspection and by the tests of clause 12.

**11.2** Appliance couplers with earthing contact shall be so constructed that, when inserting the connector, the earth connection is made before the current-carrying contacts of the appliance inlet are energized.

When withdrawing a connector, the current-carrying contacts shall separate before the earth connection is broken.

For appliance couplers not complying with the standard sheets, compliance is checked by inspection of drawings, taking into account the effect of tolerances, and by checking the specimens against these drawings.

NOTE Conformity to the standard sheets ensures compliance with this requirement.

## **12 Terminals and terminations**

### **12.1 General**

The requirements of this clause apply only to connectors.

For appliance inlets submitted as individual accessories not integrated or incorporated in an appliance or equipment, particular requirements are under consideration.

For appliance inlets incorporated in equipment, the requirements in the appropriate IEC standard for that equipment shall apply.

**12.2** Rewirable connectors shall be provided with clamping units according to IEC 60999-1.

Non-rewirable connectors shall be provided with soldered, welded, crimped or equally effective screwless connections, which shall not allow the possibility to disconnect the conductor. Screwed connections shall not be used.

The end of a stranded conductor shall not be consolidated by soft soldering at places where the conductor is subject to contact pressure unless the clamping means is designed so as to obviate the risk of a bad contact due to cold flow of the solder.

**12.3** Rewirable connectors with a rated current not exceeding 16 A shall have a rated connecting capacity of 1,5 mm<sup>2</sup> according to IEC 60999-1.

Compliance is checked by the relevant tests of IEC 60999-1.

**12.4** Clamping units shall be so fixed or located within the connector that when operated, the clamping units shall not work loose and creepage distances and clearances shall not be reduced below the values specified.

NOTE 1 These requirements do not imply the terminals should be so designed that their rotation or displacement is prevented, but any movement should be sufficiently limited so as to prevent non-compliance with this standard.

NOTE 2 The use of sealing compound or resin is considered to be sufficient for preventing a terminal from working loose, provided that

- the sealing compound or resin is not subject to stress during normal use, and
- the effectiveness of the sealing compound or resin is not impaired by temperatures attained by the terminal under the most unfavourable conditions as specified in this standard.

Compliance is checked by the relevant tests of IEC 60999-1.

**12.5** Clamping units for earthing conductors shall be of the same size as the corresponding terminals for the current carrying conductors.

Compliance is checked by inspection.

## 13 Construction

**13.1** Appliance couplers shall be so designed that there is no risk of accidental contact between the earthing contact of the appliance inlet and the current-carrying contacts of the connector.

Compliance is checked by inspection.

NOTE Conformity to the standard sheets ensures compliance with this requirement.

**13.2** Screws which fix a part providing protection against electric shock, for example the part covering the contacts of a connector, shall be adequately locked against loosening.

Compliance is checked by inspection and by the tests of clauses 18, 20 and 23.



**13.3** Pins of appliance inlets and contacts of connectors shall be locked against rotation.

Compliance is checked by inspection and by manual test.

NOTE Clamping screws may serve to prevent contacts from rotating.

**13.4** Pins of appliance inlets shall be securely retained and shall have adequate mechanical strength. It shall not be possible to remove them without the aid of a tool and they shall be surrounded by a shroud.

NOTE 1 This requirement does not exclude pins which are to some extent floating.

NOTE 2 The extent of permissible floating is not checked by measurement, but by using a gauge.

Compliance is checked by inspection, by manual test and, for non-solid pins, by the following test which is made after all other tests have been completed.

The shroud is removed from the appliance inlet and the pin supported as shown in figure 11.

A force of 100 N is exerted on the pin for 1 min in a direction perpendicular to the axis of the pin, by means of a steel rod having a diameter of 4,8 mm, the axis of which is also at right angles to the axis of the pin.

After the test, there shall be no significant alteration in the shape of the pin.

The security of the pin retention is checked by inspection and, in case of doubt, by the following test.

The specimen is heated to its appropriate temperature class given in 7.1.1 for 1 h and maintained at this temperature for the duration of the test including the 5 min period after removal of the test load.

The appliance inlet is held firmly in such a manner that there will be no undue squeezing or distortion of the body, and the means of holding shall not assist in maintaining the pins in their original position.

Each pin is subjected to a force of  $60 \text{ N} \pm 0,6 \text{ N}$ , applied without jerks, in a direction along the axis of the pin and maintained at this value for a period of 60 s.

For all pins the force is applied, first in the direction away from the base of the appliance inlet, and then in the direction towards the base of the appliance inlet.

The attachment of the pins is deemed to be satisfactory if there is no movement exceeding 2,5 mm during the test on any pin, and provided that within 5 min after removal of the pushing-in test force or within 5 min after the removal of the pulling-out test force, all pins remain within the tolerances specified in the relevant standard sheet.

**13.5** Contacts of connectors shall be self-adjusting so as to provide adequate contact pressure.

For connectors other than 0,2 A connectors, self-adjustment of the contacts shall not depend upon the resiliency of insulating material.

Compliance is checked by inspection and by the tests of clauses 16 to 21 inclusive.

**13.6** The enclosure of rewirable connectors shall consist of more than one part and shall completely enclose the terminals and the ends of the cord, at least as far as to the point from which the sheath has to be removed.

NOTE Parts of the enclosure linked together by flexible means are considered to be separate parts.

The construction shall be such that, from the point of separation of the cores, the conductors can be properly connected and that, when the connector is assembled and wired as in normal use, there is no risk of

- pressing the cores together in such a way that it causes damage to the core insulation, likely to result in a break-down of the insulation;
- a core, the conductor of which is connected to a live terminal, being likely to be pressed against accessible metal parts;
- a core, the conductor of which is connected to the earthing terminals, being likely to be pressed against live parts.

**13.7** For rewirable connectors, it shall not be possible to assemble the connector in such a way that the terminals are enclosed and the contacts are accessible.

NOTE This requirement excludes the use of separate front pieces enclosing only the contacts.

**13.8** Parts of the body of connectors shall be reliably fixed to one another, and it shall not be possible to dismantle the connector without the aid of a tool.

For rewirable connectors there shall be separate independent means for fixing and locating the parts of the body with respect to each other, at least one of which, for example a screw, can only be operated with the aid of a tool; thread-cutting screws shall not be used for this purpose.

The resiliency of the contacts shall not depend upon the assembly of the parts of the body.

Partial loosening of assembly screws or the like shall not allow the detachment of parts providing protection against electric shock.

Compliance with the requirements of 13.6 to 13.8 is checked by inspection, by manual test and by the test of 23.7.

NOTE 1 The requirement that it shall not be possible to dismantle the connectors without the aid of a tool does not necessarily mean that their component parts should be fixed to the enclosure.

NOTE 2 The requirement with regard to fixing and locating does not preclude the use of one fixing and one locating means.

**13.9** For connectors, the earthing contact shall be fixed to the body. If the earthing contact and the earthing terminal are not in one piece, the various parts shall be fixed together by riveting, welding or in a similar reliable manner.

The connection between the earthing contact and the earthing terminal shall be of metal which is resistant to corrosion.

Compliance is checked by inspection and, if necessary, by special tests.

NOTE 1 This requirement does not exclude earthing contacts which are to some extent floating.

NOTE 2 The extent of permissible floating is not checked by measurement but by using a gauge.

**13.10** Terminals of rewirable accessories and terminations of non-rewirable accessories shall be so located or shielded that loose wires of a conductor in the accessory will not present a risk of electric shock.

For non-rewirable moulded-on accessories, means shall be provided to prevent loose wires of a conductor from reducing the minimum isolation distance requirements between such wires and all accessible external surfaces of the accessory, with the exception of the engagement face of the inlet.

Compliance is checked by the following:

- for rewirable accessories the test of 13.10.1;
- for non-rewirable non-moulded-on accessories the test of 13.10.2;
- for non-rewirable moulded-on accessories by verification and inspection according to 13.10.3.

**13.10.1** A length of 6 mm of insulation is removed from the end of a flexible conductor, having a cross-sectional area of 0,75 mm<sup>2</sup>. One wire of the flexible conductor is left free and the remaining wires are fully inserted into and clamped in the terminal, as for normal use.

The free wire is bent, without tearing the insulation back, in every possible direction, but without making sharp bends around barriers.

NOTE The prohibition against making sharp bends around barriers does not imply that the free wire has to be kept straight during the test. Sharp bends, moreover, are made if it is considered likely that such bends can occur during the normal assembly of the accessory, for example when a cover is pushed on.

The free wire of a conductor connected to a live terminal shall not touch any accessible metal part or be able to emerge from the enclosure when the accessory has been assembled.

The free wire of a conductor connected to an earthing terminal shall not touch a live part.

If necessary the test is repeated with the free wire in another position.

**13.10.2** A length of insulation equivalent to the maximum designed stripping length declared by the manufacturer plus 2 mm is removed from the end of a flexible conductor having the cross-sectional area as fitted. One wire of the flexible conductor is left free in the worst position whilst the remaining wires are terminated in a manner as used in the construction of the accessory.

The free wire is bent, without tearing the insulation back, in every possible direction but without making sharp bends around barriers.

NOTE The prohibition against making sharp bends around barriers does not imply that the free wire has to be kept straight during the test. Sharp bends, moreover, are made if it is considered likely that such bends can occur during the normal assembly of the accessory, for example when a cover is pushed on.

The free wire of a conductor connected to a live termination shall not touch any accessible metal part or reduce the creepage distance and clearance through any constructional gap to the external surface below 1,5 mm.

The free wire of a conductor connected to an earth termination shall not touch any live parts.

**13.10.3** Non-rewirable moulded-on accessories shall be inspected to verify that there are means to prevent stray wires of the conductor and/or live parts reducing the minimum distance through insulation to the external accessible surface (with the exception of the engagement face of inlets) below 1,5 mm.

NOTE The verification of means may require the checking of the product construction or assembly method.

**13.11** Connectors without earthing contact and 2,5 A connectors with earthing contact shall be part of a cord set.

Compliance is checked by inspection.

**13.12** Fuses, relays, thermostats and thermal cut-outs shall not be incorporated in connectors complying with the standard sheets.

Fuses, relays, thermostats and thermal cut-outs incorporated in appliance inlets shall comply with the relevant IEC standards.

Switches and energy regulators incorporated in connectors or appliance inlets shall comply with IEC 61058 and IEC 60730 respectively.

Where an appliance inlet is integrated or incorporated in an appliance or equipment, then that part which can be identified as the appliance inlet, by reference to the relevant standard sheet, shall comply with the requirements of this standard.

Compliance is checked by inspection and by testing the switches, fuses, relays, thermostats, thermal cut-outs and energy regulators according to the relevant IEC standard.

## **14 Moisture resistance**

Appliance couplers shall be proof against humid conditions which may occur in normal use.

NOTE If such couplers are used with equipment which is subject to spillage of liquid in normal use then the protection against moisture shall be provided by the equipment.

Compliance is checked by the humidity treatment described in this clause, followed immediately by the tests of clause 15.

Connectors and appliance inlets are not in engagement when subjected to the humidity treatment; rewirable connectors are not fitted with a cord.

The humidity treatment is carried out in a humidity cabinet containing air with a relative humidity maintained between 91 % and 95 %. The temperature of the air, at all places where specimens can be located, is maintained within  $\pm 1$  °C of any convenient value  $t$  °C between 20 °C and 30 °C.

Before being placed in the humidity cabinet, the specimens are brought to a temperature between  $t$  °C and  $(t+4)$  °C.

The specimens are kept in the cabinet for

- 168 h (7 days) for connectors with earthing contact and for appliance inlets with earthing contact, which are submitted as individual accessories, not incorporated in other equipment;
- 48 h (2 days) in all other cases.

NOTE 1 In most cases, the specimens may be brought to the specified temperature by keeping them at this temperature for at least 4 h before the humidity treatment.

NOTE 2 A relative humidity between 91 % and 95 % can be obtained by placing in the humidity cabinet a saturated solution of sodium sulphate ( $\text{Na}_2\text{SO}_4$ ) or potassium nitrate ( $\text{KNO}_3$ ) in water, having a sufficiently large contact surface with the air.

NOTE 3 In order to achieve specified conditions within the cabinet, it is necessary to ensure constant circulation of the air within and, in general, to use a cabinet which is thermally insulated.

After this treatment, the specimen shall show no damage within the meaning of this standard.

## 15 Insulation resistance and electric strength

**15.1** The insulation resistance and the electric strength of appliance couplers shall be adequate.

Compliance is checked by the tests of 15.2 and 15.3, these tests being made immediately after the test of clause 14, in the humidity cabinet or in the room in which the specimens were brought to the prescribed temperature.

Indicators which might otherwise be damaged by the tests of 15.2 and 15.3, such as neon lamps, shall be disconnected at one pole prior to testing.

**15.2** The insulation resistance is measured with a d.c. voltage of approximately 500 V applied, each measurement being made  $60 \text{ s} \pm 5 \text{ s}$  after the application of the voltage.

The insulation resistance is measured

- a) for appliance inlets with a connector in engagement, between the current-carrying pins connected together and the body;
- b) for appliance inlets with a connector in engagement, between each pin in turn and the others connected together;
- c) for connectors, between the current-carrying contacts connected together and the body;
- d) for connectors, between each contact in turn and the others connected together;
- e) for rewirable connectors, between any metal part of the cord anchorage, including clamping screws, and the earthing contact or earthing terminal;
- f) for rewirable connectors, between any metal part of the cord anchorage, excluding clamping screws, and a metal rod, of the maximum diameter of the cord  $\begin{matrix} +0 \\ -1 \end{matrix}$  mm, inserted in its place.

**Table 2 – Maximum diameters of the cords**

Type of cord	Number of cores and nominal cross-sectional area mm <sup>2</sup>	Maximum diameter mm
60227 IEC 53	3 × 0,75	8,0
	3 × 1	8,4
	3 × 1,5	9,8
60245 IEC 53	3 × 0,75	8,8
	3 × 1	9,2
	3 × 1,5	11,0

The insulation resistance shall be not less than 5 MΩ.

The term "body" used in items a) and c) above includes all accessible metal parts, fixing screws, external assembly screws and the like and a metal foil in contact with the outer surface of external parts of insulating material, in item c) including the engagement face of connectors. The metal foil is wrapped round the outer surface of external parts of insulating material; however, it is not pressed into openings.

**15.3** A voltage of substantially sine-wave form with a frequency between 50 Hz and 60 Hz is applied for a period of not less than  $60 \text{ s} \pm 5 \text{ s}$  between the parts as indicated in 15.2.

The value of the test voltage is  $3\,000 \text{ V} \pm 60 \text{ V}$  when applied between the parts and the body specified in items a) and c) and  $1\,500 \text{ V} \pm 60 \text{ V}$  in all other cases. Initially, not more than half the prescribed voltage is applied, and then it is raised rapidly to the full value.

No flashover or breakdown shall occur during the test.

NOTE 1 The high-voltage transformer used for the test is so designed that, when the output terminals are short-circuited after the output voltage has been adjusted to the appropriate test voltage, the output current is at least 200 mA. The overcurrent relay must not trip when the output current is less than 100 mA.

NOTE 2 Care is taken that the r.m.s. value of the test voltage is measured within  $\pm 3 \%$ .

NOTE 3 Glow discharges without drop in voltage are neglected.

## 16 Forces necessary to insert and to withdraw the connector

**16.1** The construction of appliance couplers shall allow the easy insertion and withdrawal of the connector, and prevent the connector from working out of the appliance inlet in normal use.

Compliance is checked for connectors only by

- the test of 16.2 to ascertain that the maximum force necessary to withdraw the connector from the appliance inlet is not higher than the force specified in table 3;
- the test of 16.3 to ascertain that the minimum force necessary to withdraw a single pin gauge from the individual contact assembly is not lower than the force specified in table 3.

**Table 3 – Maximum and minimum withdrawal forces**

Type of connector	Withdrawal forces N	
	Multi-pin gauge maximum	Single-pin minimum
0,2 A, 2,5 A, 6 A and 10 A	50	1,5
16 A	60	2

The tests are repeated after the tests of clause 21.

Accessories with retaining devices are tested with the retaining device inoperative.

### 16.2 Verification of the maximum withdrawal force

The appliance inlet is fixed to the mounting plate A of an apparatus as shown in figure 12, so that the axes of the appliance inlet pin are vertical and the free ends of the pins are downwards.

For testing connectors for hot conditions and those for very hot conditions, a heating device C is provided, and on this the appliance inlet is mounted.

The appliance inlet has finely ground pins of hardened steel, having a surface roughness not exceeding  $0,8 \mu\text{m}$  over their active length and spaced at the nominal distance with a tolerance of  ${}^{+0,02}_0$  mm.

The pin dimensions have the maximum values, with a tolerance of  ${}^0_{-0,01}$  mm, except that the pin length need only comply with the tolerance of the standard sheet, and the inner dimensions of the shroud have the minimum values, with a tolerance of  ${}^{+0,1}_0$  mm, specified in the relevant standard sheet.

NOTE 1 The maximum value is the nominal plus the maximum tolerance. The minimum value is the nominal minus the maximum tolerance.

The pins are wiped free from grease before each test using a cold chemical degreaser.

NOTE 2 When using the liquid specified for the test, adequate precautions should be taken to prevent inhalation of vapour.

The connector is inserted to the full depth into and withdrawn from the appropriate appliance inlet 10 times. It is then again inserted, a carrier E for a principal mass F and a supplementary mass G being attached to it by means of a suitable clamp D. The supplementary mass is such that it exerts a force equal to one-tenth of the maximum withdrawal force specified in the table of 16.1 and it shall be made in one piece.

The principal mass is hung on the connector without jolting and the supplementary mass is allowed to fall from a height of 5 cm on to the principal mass. The connector shall not remain in the appliance inlet.

### 16.3 Verification of the minimum withdrawal force

The test pin gauge, as illustrated in figure 30, is applied to each individual connector contact with the contact axes vertical and the gauge hanging vertically downwards.

The test pin gauge is made of hardened steel, having a surface roughness not exceeding  $0,8 \mu\text{m}$  over its active length.

The pin portion of the gauge shall have dimensions equal to the minimum shown in the appropriate appliance inlet standard sheet  ${}^{+0,01}_0$  mm except that the pin length need only comply with the tolerance of the standard sheet.

The total mass of the gauge shall be such as to exert the applicable force as shown in table 3.

The pin is wiped free from grease before each test using a cold chemical degreaser.

NOTE When using the liquid specified for the test, adequate precautions should be taken to prevent inhalation of vapour.

The test pin gauge is then inserted into the contact assembly.

The test pin gauge is applied gently, and care is taken not to knock the assembly when checking the minimum withdrawal force.

The gauge shall not fall from the contact assembly within 3 s.

## 17 Operation of contacts

Contacts and pins of appliance couplers shall make connection with a sliding action. The contacts of connectors shall provide adequate contact pressure and shall not deteriorate in normal use.

The effectiveness of the pressure between contacts and pins shall not depend upon the resiliency of the insulating material on which they are mounted.

Compliance with the requirements is checked by inspection and by the tests of clauses 16, 18, 19, 20 and 21.

## 18 Resistance to heating of appliance couplers for hot conditions or very hot conditions

**18.1** Appliance couplers for hot conditions and those for very hot conditions shall withstand the heating to which they may be subjected by an appliance or other equipment.

Connectors for hot and very hot conditions shall be so constructed that the body shall not allow separation from the front during the tests and the insulation of the core of the cord shall not be subjected to excessive heating.

Compliance is checked, for connectors, by the test of 18.2, and, for appliance inlets, by the test of 18.3.

**18.2** Rewirable connectors are fitted with a three-core rubber insulated cord, having a cross-sectional area of 1,5 mm<sup>2</sup>; non-rewirable connectors are tested with the cord as delivered.

The connector is inserted into the appliance inlet of an appropriate test apparatus, an example of which is given in figure 13, where it remains for 96 h (four days). Throughout this period, the temperature at the base of the pins is maintained at

- 120 °C ± 2 °C for connectors for hot conditions;
- 155 °C ± 2 °C for connectors for very hot conditions.

For 10 A connectors, the appliance inlet is flush-mounted and has a shroud of insulating material.

For 16 A connectors, the appliance inlet is surface-mounted and has a shroud of metal.

The appliance inlets are of a type corresponding to the connector to be tested and have brass pins of the dimensions specified in the relevant standard sheet.

During the test, the temperature rise at the point of separation of the cores of the cord shall not exceed 50 K.

Temperatures are determined by means of thermocouples.

After removal from the test apparatus, one of the connectors shall be subjected to the test of 23.7 within 15 s. The connectors are then allowed to cool down to approximately ambient air temperature and are inserted into and withdrawn from the appliance inlet 10 times.



After the test, the connector shall show no damage within the meaning of this standard.

In particular, the specimen shall show

- no damage affecting the protection against electric shock;
- no loosening of electrical or mechanical connections;
- no cracks, swelling, shrinkage or the like.

NOTE 1 Care is taken to make the test in still air. It is recommended that the test apparatus be placed in a closed cabinet or similar compartment having a sufficiently large volume.

NOTE 2 The point of separation of the cores is considered to be the point beyond which the cores of the cord cannot come into contact with each other, even if the connector is knocked or allowed to fall.

NOTE 3 If the insulation of the cores of the cord of a non-rewirable connector can withstand a temperature exceeding 75 °C, a higher temperature rise may be allowed at the point of separation, provided the temperature does not exceed the value which has been proved permissible for the insulation of the cores.

NOTE 4 A revision of this test is under consideration.

**18.3** Appliance inlets for hot conditions and those for very hot conditions, other than those integrated or incorporated in an appliance or equipment, are kept for 96 h (four days) in a heating cabinet, the temperature of which is maintained at

- 120 °C ± 2 °C for appliance inlets for hot conditions;
- 155 °C ± 2 °C for appliance inlets for very hot conditions.

After the test, the specimen shall show no damage impairing its further use.

NOTE Appliance inlets integrated or incorporated in an appliance or equipment are tested together with the appliance or equipment.

## 19 Breaking capacity

Appliance couplers shall have adequate breaking capacity.

Compliance is checked, for connectors other than 0,2 A connectors, by the following test.

The connector is mounted in an appropriate test apparatus, which incorporates an appliance inlet having polished, hardened steel pins, and dimensions as specified in the relevant standard sheet. The ends of the pins shall be rounded for rectangular pins and hemispherical for round pins as shown in the standard sheets.

The appliance inlet is positioned so that the plane through the axes of the pins is horizontal and the earthing pin, if any, is uppermost.

The test apparatus shall be designed and adjusted so as to simulate as far as possible disconnection in normal use.

For 10 A and 16 A connectors with earthing contact, the appliance inlet has a metal shroud; for other connectors, the shroud is of insulating material.

The connector and the appliance inlet are connected and disconnected 50 times (100 strokes), at a rate of 30 strokes per minute. The length of a stroke of the test apparatus is between 50 mm and 60 mm.

The periods during which the test current is passed from the connection to the subsequent disconnection of the accessories are  $1,5 \begin{smallmatrix} +0,5 \\ 0 \end{smallmatrix}$  s.

The connections are as shown in figure 15. The test voltage is 275 V, the test current is 1,25 times rated current and the power factor is at least 0,95 for 10 A and 16 A connectors and  $0,6 \pm 0,05$  for other connectors.

No current is passed through the earthing circuit, if any.

The selector switch C, connecting the earthing circuit and accessible metal parts to one of the poles of the supply, is operated after half the number of strokes.

If an air-core inductor is used, a resistor taking approximately 1 % of the current through the inductor is connected in parallel with it. Iron-core inductors may be used, provided the current is of substantially sine-wave form.

During the test, there shall be no flashover between live parts of different polarity or between such parts and parts of the earthing circuit, if any, neither shall there be any sustained arcing.

After the test, the specimen shall show no damage impairing its further use and the entry holes for the pins shall not show any serious damage.

NOTE 1 In case of doubt, the test is repeated with new pins, having a surface roughness not exceeding  $0,8 \mu\text{m}$  over their active length, fitted in the appliance inlet of the test apparatus. If the new set of three specimens withstands the repeated test with new pins, the connector is considered to comply with the requirement.

NOTE 2 A stroke is an insertion or a withdrawal of the connector.

NOTE 3 Appliance inlets and 0,2 A connectors are not tested for breaking capacity.

## 20 Normal operation

Appliance couplers shall withstand, without excessive wear or other harmful effects, the mechanical, electrical and thermal stresses occurring in normal use.

Compliance is checked by testing connectors in the apparatus described in clause 19.

0,2 A connectors and the appliance inlet are connected and disconnected 2 000 times (4 000 strokes) without current flowing.

Other connectors and the appliance inlet are connected and disconnected 1 000 times (2 000 strokes) at rated current and 3 000 times (6 000 strokes) without current flowing.

The connections and the other test conditions are as specified in clause 19, except that the test voltage is 250 V.

The selector switch C, connecting the earthing circuit and accessible metal parts to one of the poles of the supply, is operated after half the number of strokes at rated current.

After the test, the specimens shall withstand an electric strength test as specified in 15.3, the test voltage being, however, reduced to 1 500 V.

The specimen shall show

- no wear impairing its further use;
- no deterioration of enclosures or barriers;
- no damage to the entry holes for the pins that might impair proper working;
- no loosening of electrical or mechanical connections;
- no seepage of sealing compound.

NOTE 1 The humidity treatment is not repeated before the electric strength test of this clause.

NOTE 2 Appliance inlets are not tested for normal operation.

## 21 Temperature rise

Contacts and other current-carrying parts shall be so designed as to prevent excessive temperature rise due to the passage of current.

Compliance is checked, for connectors other than 0,2 A connectors, by the following test.

Rewirable connectors are fitted with polyvinyl chloride insulated cords having a length of 1 m and a cross-sectional area of 1 mm<sup>2</sup> for 10 A connectors and 1,5 mm<sup>2</sup> for 16 A connectors. Screws of clamping units, if any, are tightened with the torque values specified in the appropriate column of Table 8 of 25.1.

Non-rewirable connectors are tested with the cord as delivered.

The connector is inserted into an appliance inlet having brass pins with the minimum dimensions specified in the relevant standard sheet, a tolerance of +0,02 mm being allowed, the distance between pin centres having the value specified in the standard sheet.

An alternating current of 1,25 times rated current is passed through the current-carrying contacts for 1 h.

For connectors with earthing contact, the current is then passed through one current-carrying contact and the earthing contact for 1 h.

The temperature is determined by means of melting particles, colour-changing indicators or thermocouples, which are so chosen and positioned that they have a negligible effect on the temperature being determined.

The temperature rise of terminals and contacts shall not exceed 45 K.

After this test, the second set of three specimens specified in 5.5 shall withstand the test of clause 16.

NOTE 1 Appliance inlets and 0,2 A connectors are not tested for temperature rise.

NOTE 2 During the test, the connector is not exposed to an external source of heat.

## 22 Cords and their connection

**22.1** Non-rewirable connectors shall be provided with a cord complying with either IEC 60227 or IEC 60245.

The cord shall be not lighter than the type and shall have a cross-sectional area not less than that specified in table 4.

**Table 4 – Type and minimum nominal cross-sectional area of cords**

Type of connector	Type of cord	Nominal cross-sectional area mm <sup>2</sup>
0,2 A	60227 IEC 41 <sup>a</sup>	–
2,5 A for class I equipment	60227 IEC 52	0,75
2,5 A for class II equipment	60227 IEC 52	0,75 <sup>b</sup>
6 A	60227 IEC 52	0,75
10 A for cold conditions	60227 IEC 53 or 60245 IEC 53	0,75 <sup>c</sup>
10 A for hot conditions	60245 IEC 51 or 60245 IEC 53	0,75 <sup>c</sup>
10 A for very hot conditions	60245 IEC 51 or 60245 IEC 53	0,75 <sup>c</sup>
16 A for cold conditions	60227 IEC 53 or 60245 IEC 53	1 <sup>c</sup>
16 A for very hot conditions	60245 IEC 51 or 60245 IEC 53	1 <sup>c</sup>
<sup>a</sup> In length not exceeding 2 m. <sup>b</sup> If the cord has a length not exceeding 2 m, a nominal cross-sectional area of 0,5 mm <sup>2</sup> is allowed. <sup>c</sup> If the cord has a length exceeding 2 m, nominal cross-sectional areas shall be – 1 mm <sup>2</sup> for 10 A connectors; – 1,5 mm <sup>2</sup> for 16 A connectors.		

Non-rewirable connectors shall be provided with a type of cord complying with the standard indicated in Table 4 for the type of connector and, in addition, the cord shall have a cross-sectional area not less than that specified in Table 4.

In non-rewirable, non-reversible connectors the cores of the cord shall be connected to the contacts in the following manner:

- green/yellow core to the earthing contact;
- brown core to the line contact;
- light blue core to the neutral contact.

NOTE See also the note of 8.6.

Compliance is checked by inspection, by measurement and by checking that the cords are in accordance with IEC 60227 or IEC 60245.

**22.2** Connectors shall be provided with a cord anchorage such that the conductors are relieved from strain, including twisting, where they are connected to the terminals or terminations, and that their outer covering is protected from abrasion.

NOTE Cord anchorages of the "labyrinth" type are allowed, provided they withstand the relevant tests.

**22.3** For rewirable connectors:

- it shall be clear how the relief from strain and the prevention of twisting is intended to be effected;
- the cord anchorage, or at least part of it, shall be integral with or fixed to one of the other component parts of the connector;
- makeshift methods, such as tying the cord into a knot or tying the ends with string, shall not be used;

- cord anchorages shall be suitable for the different types of cord which may be connected, and their effectiveness shall not depend upon the assembly of the parts of the body;
- cord anchorages shall be of insulating material or be provided with an insulating lining fixed to the metal parts;
- it shall not be possible for the cord to touch the clamping screws of the cord anchorage if these screws are accessible with the standard test finger shown in figure 10 or are electrically connected to accessible metal parts;
- metal parts of the cord anchorage, including its screws, shall be insulated from the earthing circuit.

Compliance with the requirements of 22.2 and 22.3 is checked by inspection and by a pull test in an apparatus similar to that shown in figure 16, followed by a torque test.

Non-rewirable connectors are tested with the cord as delivered, rewirable connectors are tested first with one and then with the other type of cord, as specified in table 5.

**Table 5 – Types of cord for the rewirable connector test**

Type of connector	Type of cord	Nominal cross-sectional area mm <sup>2</sup>
10 A for cold conditions	60227 IEC 53 60227 IEC 53	0,75 1
10 A for hot conditions	60245 IEC 53 60245 IEC 53	0,75 1
10 A for very hot conditions	60245 IEC 53 60245 IEC 53	0,75 1
16 A for cold conditions	60227 IEC 53 60227 IEC 53	1 1,5
16 A for very hot conditions	60245 IEC 53 60245 IEC 53	1 1,5

Conductors of the cord of rewirable connectors are introduced into the clamping units, and the screws of clamping units, if any, are tightened just sufficiently to prevent the conductors from easily changing their position.

The cord anchorage is used in the normal way, clamping screws being tightened with a torque equal to two-thirds of the torque specified in the appropriate column of table 8. After reassembly of the specimen, the component parts shall fit snugly and it shall not be possible to push the cord into the connector to any appreciable extent.

The specimen is fixed in the test apparatus so that the axis of the cord is vertical where it enters the connector.

The cord is then subjected 100 times to a pull of 50 N for connectors having a rated current not exceeding 2,5 A and 60 N for other connectors. The pulls are applied without jerks, each time for 1 s.

Immediately afterwards, the cord is subjected for 1 min to a torque of

- 0,1 Nm for cords, other than flat twin tinsel cords, having a nominal cross-sectional area not exceeding 0,5 mm<sup>2</sup>;
- 0,15 Nm for two-core cords having a nominal cross-sectional area of 0,75 mm<sup>2</sup>;
- 0,25 Nm in all other cases.

During the tests, the cord shall not be damaged.

After the tests, the cord shall not have been displaced by more than 2 mm. For rewirable connectors, the ends of the conductors shall not have moved noticeably in the terminals; for non-rewirable connectors, there shall be no break in the electrical connections. A visual inspection is made to ensure no undue twisting of the conductors where they are connected to the terminals or terminations. (For non-rewirable accessories this may need to be conducted at the end of the test sequence.)

For the measurement of the longitudinal displacement, a mark is made on the cord before starting the test while subjecting it to a preliminary pull of the value specified, the mark is made at a distance of approximately 2 cm from the end of the connector or the cord guard. If, for non-rewirable connectors, there is no definite end to the connector or the cord guard, an additional mark is made on the body, from which the distance to the other mark is measured.

After the tests, the displacement of the mark on the cord in relation to the connector or the cord guard is measured while the cord is subjected to a pull of the value specified.

NOTE Connectors provided with flat twin tinsel cords are not subjected to the torque test.

**22.4** Connectors shall be so designed that the cord cannot be subjected to excessive bending where it enters the connector.

Guards provided for this purpose shall be of insulating material and shall be fixed in a reliable manner.

NOTE Helical metal springs, whether bare or covered with insulating material, are not allowed as cord guards.

Compliance is checked by inspection and the following test.

For rewirable connectors, before this test is started, the guards are subjected to an accelerated ageing test as specified in

- 24.2.1, if of elastomeric material;
- 24.2.2, if of thermoplastic material.

Connectors are subjected to a test in an apparatus having an oscillating member similar to that shown in figure 17.

Rewirable connectors are fitted with a cord as specified in table 6, having an appropriate length and strands of the largest diameter allowed for that type of flexible cord. The cord guard, if any, is put in place.

**Table 6 – Type of cord and nominal cross-sectional area for rewirable connectors**

Type of connector	Type of cord	Nominal cross-sectional area mm <sup>2</sup>
10 A for cold conditions	60227 IEC 53	1
10 A for hot conditions	60245 IEC 53	1
10 A for very hot conditions	60245 IEC 53	1
16 A for cold conditions	60227 IEC 53	1,5
16 A for very hot conditions	60245 IEC 53	1,5

Non-rewirable connectors are tested with the cord as delivered.

The specimen is fixed to the oscillating member of the apparatus so that, when this is at the middle of its travel, the axis of the cord, where it enters the connector, is vertical and passes through the axis of oscillation.

The part of the connector which, in normal use, is inside the appliance inlet, is fixed in the test apparatus.

The oscillating member is, by variation of distance  $d$  shown in figure 17, so positioned that the cord makes the minimum lateral movement when the oscillating member of the test apparatus is moved over its full travel.

Specimens with flat cords are mounted so that the major axis of the section is parallel to the axis of oscillation.

The cord is loaded so that the force applied is

- 20 N for rewirable connectors, and for non-rewirable connectors with cords having a nominal cross-sectional area exceeding 0,75 mm<sup>2</sup>;
- 10 N for other non-rewirable connectors.

A current equal to the rated current of the connector is passed through the conductors, the voltage between them being equal to rated voltage.

No current is passed through the earthing conductor, if any. The oscillating member is moved backwards and forwards through an angle of 90° (45° on either side of the vertical), the number of flexings being 10 000 for rewirable connectors and 20 000 for non-rewirable connectors and the rate of flexing being 60 per minute.

Specimens with circular-section cords are turned through 90° in the oscillating member after half the required number of flexings; specimens with flat cords are only bent in a direction perpendicular to the plane containing the axes of the cores.

During the test there shall be no interruption of the test current, and no short-circuit between conductors.

After the test, the specimen shall show no damage within the meaning of this standard, the guard, if any, shall not have separated from the body and the insulation of the cord shall show no sign of abrasion or wear, moreover, for non-rewirable connectors, broken strands of the conductors shall not have pierced the insulation so as to become accessible.

NOTE 1 A flexing is one movement, either backwards or forwards.

NOTE 2 The test is carried out on specimens not subjected to any other test.

NOTE 3 A short circuit between the conductors of the cord is considered to occur if the current attains a value equal to twice the rated current of the connector.

## 23 Mechanical strength

**23.1** Appliance couplers shall have adequate mechanical strength.

Compliance is checked

- for connectors, by the test of 23.2 and for connectors with a rating exceeding 0,2 A the test of 23.3;
- for appliance inlets having a shroud of metal, by the test of 23.4;
- for appliance inlets with a shroud of insulating material intended for surface mounting, by the tests of 23.5 and 23.8;

NOTE 1 Shrouds of appliance inlets designed for flush-mounting in an appliance or other equipment are not subjected to the tests of 23.4 and 23.5.

NOTE 2 Tests for checking the mechanical strength of these appliance inlets are under consideration.

**23.2** Rewirable connectors are fitted with the cord, specified in 22.3, having the smallest cross-sectional area and a free length of approximately 100 mm, measured from the outer end of the guard.

Terminal screws and assembly screws are tightened with a torque equal to two-thirds of the torque specified in the appropriate column of the table in 25.1.

Non-rewirable connectors are tested with the cord as delivered, the cord being cut so that a free length of approximately 100 mm projects from the outer end of the guard.

The specimens are subjected one at a time to the test Ed: Free fall, procedure 2 of IEC 60068-2-32, the number of falls being

- 500 if the mass of the specimen without cord or cord guard does not exceed 200 g;
- 100 in all other cases.

After the test, the specimens shall show no damage within the meaning of this standard. In particular, no part shall have become detached or loosened.

NOTE 1 During the examination after the test, special attention is paid to the connection of the cord.

NOTE 2 Small pieces may be broken off without causing rejection, provided that protection against electric shock is not affected.

NOTE 3 Damage to finish and small dents which do not reduce the creepage distances or clearances below the values specified in clause 26 are neglected.

NOTE 4 The approximate 100 mm length may have to be reduced in order to ensure free fall.

**23.3** After the test of 23.2, the connector with a rating exceeding 0,2 A is inserted into an appliance inlet of a type corresponding with the connector to be tested and complying with the relevant standard sheet. The appliance inlet is mounted in an appropriate test apparatus, an example of which is shown in figure 19, with the pins pointing upwards. The dimension  $40 \text{ mm} \pm 2 \text{ mm}$  shall be complied with.

A lateral pull, as specified in table 7, is applied to the cord first in a direction perpendicular to the plane containing the axes of the current-carrying pins, and is immediately released.

This sequence of operation is made 50 times in one direction and then 50 times in the opposite direction.



A lateral pull of the same force is then applied in a direction parallel with the plane containing the axes of the current-carrying pins and parallel with the engagement face of the connector. The force is immediately released. This sequence of operation is made 50 times in one direction and then 50 times in the opposite direction.

**Table 7 – Values for the lateral pulls applied**

Rated current of connector A	Pull N
2,5	6
6	35
10	35
16	50

If necessary, the connector is prevented from coming out of the appliance inlet but must be free to move towards the wall of the appliance inlet.

During the test, the cord guard, if any, shall not separate from the body.

After the test, the connector shall show no damage within the meaning of this standard. In particular, the specimens shall comply with the requirements for minimum withdrawal force and withstand the test of 16.3.

NOTE The apparatus shown in figure 19 is intended for connectors where the axis of the connector and the axis of the cord coincide ("straight" connectors); for other connectors, the apparatus is adapted, so that the pulls will be applied in the most unfavourable position.

**23.4** Appliance inlets designed for surface mounting and having a shroud of metal, are compressed in an appropriate test apparatus, an example of which is shown in figure 20. The spherical end of the jaws shall have a radius of 20 mm  $\pm$  1 mm. A force of 40 N  $\pm$  2 N shall be applied for 60 s  $\pm$  6 s through the jaws to the most unfavourable point half-way up the outer surface of the shroud, in a direction perpendicular to the axis of the shroud.

After the test, there shall be no deformation or loosening of the shroud such as will impair the further use of the appliance inlet.

**23.5** Appliance inlets designed for surface-mounting and having a shroud of insulating material, other than elastomeric material, or thermoplastic material, are tested by means of the spring-operated impact-test apparatus shown in figure 21.

The apparatus consists of three main parts; the body, the striking element and the spring-loaded release cone.

The body comprises the housing, the striking element guide, the release mechanism and all parts rigidly fixed thereto. The mass of this assembly is 1 250 g.

The striking element comprises the hammer head, the hammer shaft and the cocking knob. The mass of this assembly is 250 g.

The hammer head has a hemispherical face of polyamide having a Rockwell hardness of HR 100, with a radius of 10 mm. It is fixed to the hammer shaft in such a way that the distance from its tip to the plane of the front of the cone, when the striking element is on the point of release, is 20 mm.

The cone has a mass of 60 g and the cone spring is such that it exerts a force of 20 N when the release jaws are on the point of releasing the striking element.

The hammer spring is adjusted so that the product of the compression, in millimetres, and the force exerted, in newtons, equals 1 000, the compression being approximately 20 mm. With this adjustment, the impact energy is  $0,5 \text{ J} \pm 0,05 \text{ J}$ .

The release mechanism springs are adjusted so that they exert just sufficient pressure to keep the release jaws in the engaged position.

The apparatus is cocked by pulling the cocking knob until the release jaws engage with the groove in the hammer shaft.

The blows are applied by pushing the release cone against the specimen in a direction perpendicular to the surface at the point to be tested.

The pressure is slowly increased so that the cone moves back until it is in contact with the release bars, which then move to operate the release mechanism and allow the hammer to strike.

The specimen is rigidly supported and 12 blows are applied, three to each of four places chosen so as to include the weakest areas.

After the test, the specimen shall show no damage within the meaning of this standard.

**23.6** For 2,5 A connectors for class II equipment according to standard sheet C7, the area where the switch cam(s) can touch the connector shall be sufficiently resistant to deformation.

NOTE This area is indicated by "3)" on standard sheet C7.

Compliance is checked by the following test, which is made by means of an apparatus having a rectangular blade as shown in figure 22. The test is made with blade A and with blade B successively, which are pressed against the connector body in the area to be checked, with the force as specified in figure 22.

The apparatus with the specimen in position is kept in a heating cabinet at a temperature of  $70 \text{ °C} \pm 2 \text{ °C}$  for 2 h.

The specimen is then removed from the apparatus and cooled down within 10 s to approximately room temperature by immersion in cold water.

The thickness of the connector body is measured immediately at the point of impression. The difference between the thickness values before and after the test shall be not more than 0,2 mm.

**23.7** The external parts of connectors with a separate front part enclosing the contacts shall be reliably fixed to one another.

Compliance is checked by the following test which shall be performed immediately after the test of 18.2.

The front part and the rear part of the connector are securely fixed to two claws which are so arranged that they can separate from each other in a straight line. A pull force of  $100 \text{ N} \pm 2 \text{ N}$  is applied in the axial direction without jerks to the claws. The force is maintained for 1 min. After having removed the force, a torque of 2 Nm is applied twice to the connector. First for 1 min twisting the connector in a direction perpendicular to the axis of the previous applied force and then for 1 min bending the connector in a direction perpendicular to the axis of the previous applied force and torque.

After the test, the two parts of the connector shall not have been detached, nor shall parts providing protection against electric shock have loosened or live parts become accessible.

**23.8** The shroud of the appliance inlet is subjected to a pressure test at an ambient temperature of  $25 \text{ °C} \pm 5 \text{ °C}$  in an apparatus similar to that shown in figure 24.

The specimen is clamped between steel jaws, having a cylindrical face of 25 mm radius, a width of 15 mm and an effective length between the guides of 50 mm minimum. The corners are rounded with a radius of 2,5 mm.

The specimen is clamped in such a way that the front face of the jaws coincides with the front face of the shroud.

The force applied through the jaws is  $20 \text{ N} \pm 2 \text{ N}$ .

After 1 min, and while the shroud is still under pressure, the corresponding go-gauges shall enter the appliance inlet. In case of doubt, and where no gauges exist, the inner dimensions of the shroud have to be measured. The dimensions shall comply with the appropriate standard sheet.

The test is repeated with the specimen rotated  $90^\circ$ .

## **24 Resistance to heat and ageing**

**24.1** Appliance couplers shall be sufficiently resistant to heat.

Compliance is checked by the tests of 24.1.1 to 24.1.3 as applicable.

**24.1.1** Specimens of connectors and appliance inlets other than those integrated or incorporated in an appliance or equipment are kept for 1 h in a heating cabinet at a temperature of  $100 \text{ °C} \pm 2 \text{ °C}$ .

During the test, the specimen shall not undergo any change impairing its further use, and sealing compound shall not flow to such an extent that live parts are exposed.

NOTE 1 If connectors and appliance inlets are submitted together, they are tested while in engagement.

NOTE 2 A slight displacement of the sealing compound is neglected, provided that safety is not impaired.

**24.1.2** Parts of insulating material, of appliance inlets not integrated in or incorporated in an appliance or equipment and of connectors other than 0,2 A connectors, shall be subjected to a ball-pressure test by means of the apparatus shown in Figure 23.

Parts of the cord anchorage and the cord guard, parts not immediately surrounding the socket contacts of connectors moulded together with the cord, and parts of ceramic are not subjected to this test.

Before the test is started, the ball and the support on which the specimen shall be placed, are brought to the temperature specified. The part under test shall be placed on a 3 mm thick steel plate in direct contact with it, so as to be supported to withstand the test force. When it is not possible to carry out the test on the specimen, the test shall be carried out on a specimen of the same material at least 2 mm thick.

The surface of the part to be tested is placed in the horizontal position and a steel ball of 5 mm diameter is pressed against the surface with a force of 20 N.

The test is made in a heating cabinet maintained at a temperature of

- 155 °C ± 2 °C in the case of accessories for very hot conditions;
- 125 °C ± 2 °C in the case of accessories for hot conditions;
- 125 °C ± 2 °C for those parts of accessories for cold conditions which retain current-carrying parts and parts of the earthing circuit in position;
- 75 °C ± 2 °C for other parts of accessories for cold conditions and all parts of 0,2 A appliance inlets.

After 1 h, the ball is removed from the specimen which is then cooled down, within 10 s, to approximately room temperature by immersion in cold water.

The diameter of the impression caused by the ball is measured and shall not exceed 2 mm.

**24.1.3** Connectors of thermoplastic material are subjected to a pressure test in an apparatus similar to that shown in figure 24, the test being made in a heating cabinet at a temperature of 100 °C ± 2 °C.

The specimen is clamped between steel jaws, having a cylindrical face of 25 mm radius, a width of 15 mm and a length of 50 mm. The corners are rounded with a radius of 2,5 mm.

The specimen is clamped in such a way that the jaws press against it in the area where it is gripped in normal use, the centre line of the jaws coinciding as nearly as possible with the centre of this area.

The force applied through the jaws is 20 N.

After 1 h, the jaws are removed and the specimen shall show no damage within the meaning of this standard.

**24.2** Connectors of elastomeric or thermoplastic shall be sufficiently resistant to ageing.

Compliance is checked:

- for connectors of elastomeric material, by the tests of 24.2.1 and 24.2.3;
- for connectors of thermoplastic material, by the tests of 24.2.2 and 24.2.3.

For the tests of 24.2.1 to 24.2.3, two new specimens are used, which are first subjected to the test of clause 16.

NOTE 1 For the tests of 24.2.1 and 24.2.2, the use of an electrically heated cabinet is recommended.

NOTE 2 Natural air circulation may be provided by holes in the walls of the cabinet.

NOTE 3 Temperature may be measured by means of thermometers.

**24.2.1** Connectors of elastomeric material are subjected to an accelerated ageing test made in an atmosphere having the composition and pressure of the ambient air. The specimens are suspended freely in a heating cabinet, ventilated by natural air circulation. They are kept in the cabinet, which is maintained at a temperature of  $70\text{ °C} \pm 2\text{ °C}$ , for 240 h (10 days).

**24.2.2** Connectors of thermoplastic material are subjected to an accelerated ageing test made in an atmosphere having the composition and pressure of the ambient air. The specimens are suspended freely in a heating cabinet, ventilated by natural circulation. They are kept in the cabinet, which is maintained at a temperature of  $80\text{ °C} \pm 2\text{ °C}$ , for 168 h (7 days).

During the test, the connectors are in engagement with a corresponding appliance inlet according to the relevant standard sheet.

**24.2.3** After the tests of 24.2.1 or 24.2.2 the specimens are allowed to attain approximately ambient temperature and are then examined. They shall show no crack visible to the naked eye, nor shall the material have become sticky or greasy, this being judged as follows.

A forefinger wrapped in a dry piece of rough cloth is pressed on the specimen with a force of 5 N.

No traces of the cloth shall remain on the specimen and the material of the specimen shall not stick to the cloth.

After this test, the specimen shall show no damage which would lead to non-compliance with this standard.

NOTE The force of 5 N can be obtained in the following way.

The specimen is placed on one of the pans of a balance and the other pan is loaded with a mass equal to the mass of the specimen plus 500 g. Equilibrium is then restored by pressing the specimen with the forefinger, wrapped in the piece of cloth.

## **25 Screws, current-carrying parts and connections**

**25.1** Connections, electrical or mechanical, shall withstand the mechanical stresses occurring in normal use.

Screws and nuts which transmit contact pressure and which are operated when connecting and mounting an accessory during installation, and/or which are likely to be operated during the life of the accessory, shall be in engagement with a metal thread.

Screws for connecting conductors shall not be tapping screws.

Screws and nuts operated when mounting the accessory during installation, and/or which are likely to be operated during the life of the accessory shall not be of the thread-cutting type.

NOTE Screws or nuts which are operated when mounting the accessory include screws for fixing covers or cover plates, etc, but not screws for fixing the base of the appliance inlet.

Compliance is checked by inspection and for screws and nuts which transmit contact pressure and for screws which are operated when connecting and mounting an accessory during installation and/or which are likely to be operated during the life of the accessory, by the following test.

The screws and nuts are tightened and loosened:

- 10 times for metal screws in engagement with a thread of insulating material and for screws of insulating material;
- 5 times in all other cases.

Screws or nuts in engagement with a thread of insulating material and screws of insulating material are completely removed and reinserted each time. The test is made by means of a suitable test screwdriver or spanner applying a torque as shown in the following table.

NOTE The shape of the blade of the test screwdriver shall suit the head of the screw to be tested.

When testing terminal screws of connectors, a flexible conductor is placed in the terminal. The conductor is moved each time the screw or nut is loosened.

The nominal cross-sectional area of this conductor is 1 mm<sup>2</sup> for 10 A connectors and 1,5 mm<sup>2</sup> for 16 A connectors.

The screws and nuts shall be tightened smoothly.

**Table 8 – Torque applied for the tightening and loosening test**

Nominal diameter of thread mm	Torque Nm	
	I	II
Up to and including 2,8	0,2	0,4
Over 2,8 up to and including 3,0	0,25	0,5
Over 3,0 up to and including 3,2	0,3	0,6
Over 3,2 up to and including 3,6	0,4	0,8
Over 3,6 up to and including 4,1	0,7	1,2
Over 4,1 up to and including 4,7	0,8	1,8
Over 4,7 up to and including 5,3	0,8	2,0

Column I applies to screws without heads which, when tightened, do not protrude from the hole, and to other screws which cannot be tightened by means of a screwdriver with a blade wider than the diameter of the screw.

Column II applies to other screws and to nuts.

For screws having a hexagonal head with a slot, only the test with the screwdriver is made.

During the test, the screwed connection shall not work loose and there shall be no damage, such as breakage of screws or damage to the head slots, threads, washers or stirrups, that will impair the further use of the accessory.

NOTE Screwed connections will have been partially checked by the tests of clauses 20 and 23.

**25.2** For screws intended to be engaged with a thread of insulating material and screws of insulating material, which are operated for the installation of the accessory and/or which are likely to be operated during the life of the accessory, correct introduction of the screw into the screw hole or nut shall be ensured.

Screws of insulating material shall not be used in cases when the replacement with metal screws could impair the insulation of the appliance coupler.

Compliance is checked by inspection and by manual test.

NOTE The requirement with regard to correct introduction is met if introduction of the screw in a slanting manner is prevented, for example, by guiding the screw by the part to be fixed, by a recess in the female thread, or by the use of a screw with the leading thread removed.

**25.3** Electrical connections shall be so designed that contact pressure is not transmitted through insulating material other than ceramic or other material with characteristics at least equivalent.

This requirement does not apply to appliance couplers for cold conditions, if there is sufficient resiliency in the metallic parts to compensate for any possible shrinkage or yielding of the insulating material.

NOTE The suitability of the material is considered with regard to the stability of the dimensions.

Compliance is checked by inspection.

NOTE This requirement does not preclude electrical connections with flat tinsel cord for applications up to 0,2 A where the contact pressure is obtained by insulating material having such properties as to ensure reliable and permanent contact under all conditions of normal use, especially in view of shrinking, yielding, ageing and cold flow of the insulating part.

**25.4** Screws and rivets, which serve as electrical as well as mechanical connections, shall be locked against loosening or turning.

Compliance is checked by inspection and manual test.

NOTE 1 Spring washers may provide satisfactory locking.

NOTE 2 For rivets, a non-circular shank or an appropriate notch may be sufficient.

NOTE 3 Sealing compound which softens on heating provides satisfactory locking only for screw connections not subject to torsion in normal use.

**25.5** Connections between terminals and other parts shall be so designed that they will not work loose in normal use.

Compliance is checked by inspection and manual test.

**25.6** Current-carrying parts and earthing contacts shall be of a metal having, under conditions occurring in the appliance coupler, adequate mechanical strength and resistance to corrosion.

Compliance is checked by inspection and, if necessary, by chemical analysis.

Examples of suitable metals, when used within the permissible temperature range and under normal conditions of chemical pollution are:

- copper;
- an alloy containing at least 58 % copper for parts that are worked cold or at least 50 % copper for other parts;
- stainless steel containing at least 13 % chromium and not more than 0,09 % carbon;

- steel provided with an electroplated coating of zinc according to ISO 2081, the coating having a thickness of at least 5  $\mu\text{m}$  (ISO Service Condition No. 1);
- steel provided with an electroplated coating of nickel and chromium according to ISO 1456, the coating having a thickness of at least 20  $\mu\text{m}$  (ISO Service Condition No. 2);
- steel provided with an electroplated coating of tin, according to ISO 2093, the coating having a thickness equal to at least 12  $\mu\text{m}$  (ISO Service Condition No. 2).

Parts which may be subjected to mechanical wear shall not be made of steel provided with electroplated coating.

Steel provided with an electroplated coating of zinc is only permitted for prime current-carrying parts if no fixed electrical connection is intended to be made. For connections, an electroplated coating of zinc is permissible only on parts which do not participate directly in current transmission, such as screws or washers used for certain types of terminals in which they transmit only the contact pressure.

NOTE 1 The requirements of this subclause are not intended to apply to magnetic circuits, heating elements, bimetallic components, shunts, parts of electronic devices, etc.

NOTE 2 Screws, nuts, washers, clamping plates and similar parts of terminals are not regarded as current-carrying parts.

NOTE 3 New requirements to be verified by a test for determining the resistance to corrosion are under consideration. These requirements should permit other materials to be used if suitably coated.

**25.7** Under moist conditions, metals having a great difference of electro-chemical potential with respect to each other shall not be used in contact with each other.

Compliance is checked by inspection.

**25.8** Pins of appliance inlets for very hot conditions shall be protected by nickel plating or be of a material no less resistant to corrosion. The latter requirement does not apply to pins of appliance inlets integrated or incorporated in an appliance or equipment, provided their temperature does not exceed 140 °C in normal use.

Compliance is checked by inspection.

## 26 Creepage distances, clearances and distances through insulation

Creepage distances, clearances and distances through insulation of connectors and appliance inlets other than those integrated or incorporated in an appliance or equipment, shall be not less than the values shown in Table 9 if not otherwise specified in the standard sheets.

NOTE 1 For possible new standard sheets, the values of the table are valid if there are not very good reasons to have other values and thorough consideration has been given to the insulation coordination.

NOTE 2 The values of the table are valid for all dimensions not specified in the standard sheets. The note in the table specifies the possible exemptions and deviations from the values in the table.

For indicator circuits having a resistance such that the fault current will never exceed 0,25 A, under conditions of bridging any creepage distances or clearances in such circuits, the value specified may be reduced to 1,0 mm. In addition, resistors in the indicator circuit shall operate at not greater than 75 % of the manufacturer's declared and published rated dissipation.



**Table 9 – Minimum creepage distances and clearances through insulation**

<b>Creepage distances and clearances</b>	<b>mm</b>
between live parts of different polarity	3
between live parts and accessible metal parts	4*
inaccessible external screws or the like (for connectors only)	3
between parts of the earthing circuit and live parts	4
accessible screws or the like	3
inaccessible external screws or the like (for connectors only)	1,5
the cord anchorage, including its clamping screws	1,5
Thickness of insulating material between accessible metal parts and live parts	1,5
NOTE 1 For connectors, the term "accessible metal parts" includes metal foil in contact with external surfaces of insulating material.	
NOTE 2 Inaccessible screws are those which cannot be touched with the standard test finger.	
NOTE 3 The insulation may consist of solid material plus one or more air layers.	
* This value does not apply in those cases where the dimensions specified in the relevant standard sheet lead to a smaller distance.	

Compliance is checked by measurement.

For rewirable connectors, the measurements are made on specimens fitted with conductors having the largest cross-sectional area as specified in table 5 and also without conductors.

For non-rewirable connectors the measurements are made on specimens with the cord as delivered.

Connectors are tested when in engagement with an appliance inlet and also when not in engagement.

NOTE 3 The contribution to the creepage distance of any groove less than 1 mm wide is limited to its width. Any air gap less than 1 mm wide is ignored in computing the total clearance.

## **27 Resistance of insulating material to heat, fire and tracking**

**27.1** Parts made of insulating material which might be exposed to thermal stresses due to electric effects and whose deterioration might impair safety shall not be unduly affected by heat and fire generated within the accessory.

For accessories with a rated current exceeding 0,2 A compliance is checked by the glow-wire test according to 27.1.1 to 27.1.10.

Appliance inlets integrated or incorporated in an appliance or equipment are tested in accordance with the relevant appliance standard.

### 27.1.1 Object of the test

The glow-wire test is applied to ensure that an electrically heated test wire under defined test conditions does not cause ignition of insulating parts or to ensure that a part made of insulating material, which might be ignited by the heated test wire under defined conditions, burns for a limited time only and that without spreading fire by flame, or burning parts, or drops falling down from the part under test.

### 27.1.2 General description of the test

The test is made on one specimen only.

In case of doubt, the test shall be repeated on two further specimens.

The test is made by applying the glow-wire once only. The specimen shall be positioned during the test in the most unfavourable position of its intended use (with the surface tested in a vertical position).

The tip of the glow-wire shall be applied to the specified surface of the test specimen, taking into account the conditions of the intended use under which a hot part may come into contact with the specimen.

If the test cannot be made on the complete specimen, a suitable part may be cut from it.

If the specified tests are carried out at several places on the same specimen, care shall be taken to ensure that any deterioration caused by previous tests does not affect the results of the test to be made.

Small parts, such as washers, are not subjected to this test.

### 27.1.3 Description of test apparatus

Clause 5 of IEC 60695-2-10 is applicable. The pinewood board covered with a layer of wrapping tissue shall be used.

### 27.1.4 Degree of severity

The following test temperatures, selected from the preferred test temperatures specified in clause 6 of IEC 60695-2-11, IEC 60695-2-12 and IEC 60695-2-13 are applicable.

- 750 °C for parts made of insulating material intended to retain current-carrying parts and parts of the earthing circuit in position;
- 650 °C for all other parts made of insulating material.

### 27.1.5 Verification of the thermocouple

Subclause 6.2 of IEC 60695-2-10 is applicable.

### 27.1.6 Preconditioning

Clause 7 of IEC 60695-2-10 is applicable.

### 27.1.7 Initial measurements

Clause 8 of IEC 60695-2-11, IEC 60695-2-12 and IEC 60695-2-13 is applicable.

**27.1.8 Test procedure**

Clause 8 of IEC 60695-2-10 is applicable.

**27.1.9 Observations and measurements**

Clause 11 of IEC 60695-2-11, IEC 60695-2-12 and IEC 60695-2-13 is applicable.

**27.1.10 Evaluation of test results**

Clause 12 of IEC 60695-2-11, IEC 60695-2-12 and IEC 60695-2-13 is applicable.

**27.2** Insulating parts supporting, or in contact with, live parts of appliance couplers for hot conditions and of appliance couplers for very hot conditions, shall be of material resistant to tracking.

This requirement does not apply to appliance inlets integrated in or incorporated in an appliance or equipment.

For materials other than ceramic, compliance is checked by the following test.

**27.2.1 Test specimens**

Clause 3 of IEC 60112 is applicable. The test specimens are taken from the accessory to be tested.

**27.2.2 Conditioning**

Clause 4 of IEC 60112 is applicable.

**27.2.3 Test apparatus**

Clause 5 of IEC 60112 is applicable as follows:

- 5.1** – Electrodes: applicable
- 5.2** – Test circuit: applicable
- 5.3** – Dropping device: applicable
- 5.4** – Test solution: solution A shall be used

**27.2.4 Procedure**

Clause 6 of IEC 60112 is applicable as follows:

- 6.1** – General: applicable
- 6.2** – Determination of the CTI: not applicable
- 6.3** – Proof-tracking test: applicable, PTI 175 V
- 6.4** – Determination of erosion: not applicable.

## 28 Resistance to rusting

Ferrous parts shall be adequately protected against rusting.

Compliance is checked by the following test.

All grease is removed from the parts to be tested by immersion in a cold chemical degreaser, such as trichlorethane or petroleum ether, for 10 min. The parts are then immersed for 10 min in a 10 % solution of ammonium chloride at a temperature of  $20\text{ }^{\circ}\text{C} \pm 5\text{ }^{\circ}\text{C}$ .

Without drying, but after shaking off any drops, the parts are placed for 10 min in a box containing air saturated with moisture at a temperature of  $20\text{ }^{\circ}\text{C} \pm 5\text{ }^{\circ}\text{C}$ .

After the parts have been dried for 10 min in a heating cabinet at a temperature of  $100\text{ }^{\circ}\text{C} \pm 5\text{ }^{\circ}\text{C}$ , their surfaces shall show no signs of rust.

NOTE 1 Traces of rust on sharp edges and any yellowish film removable by rubbing are ignored.

NOTE 2 For small springs and the like, and for inaccessible parts exposed to abrasion, a layer of grease may provide sufficient protection against rusting. Such parts are only subjected to the test if there is doubt as to the effectiveness of the grease film, and the test is then made without previous removal of the grease.

## WARNING

When using the liquids specified for the test, adequate precautions must be taken to prevent inhalation of the vapour.

## 29 Electromagnetic compatibility (EMC) requirements

NOTE Requirements for accessories incorporating electronic components are not included as the need has not yet been established.

### 29.1 Immunity

#### 29.1.1 Accessories not incorporating electronic components

These accessories are not sensitive to normal electromagnetic disturbances and therefore no immunity tests are required.

### 29.2 Emission

#### 29.2.1 Accessories not incorporating electronic components

These accessories do not generate electromagnetic disturbances; consequently no emission tests are necessary.

NOTE These accessories may only generate electromagnetic disturbances during occasional operations of insertion and withdrawal of the accessories. The frequency, the level and the consequences of these emissions are considered as part of the normal electromagnetic environment.

## STANDARD SHEET C1

0,2 A 250 V CONNECTOR  
FOR CLASS II EQUIPMENT  
FOR COLD CONDITIONS  
(non-rewirable only)

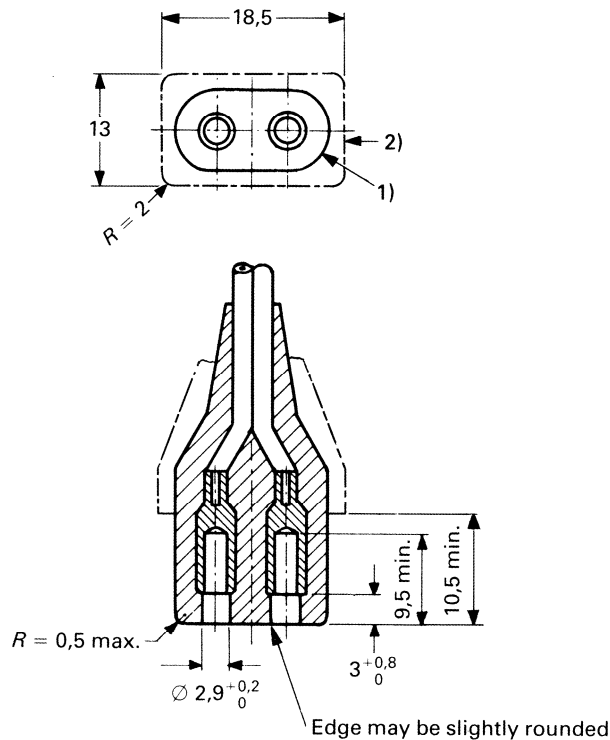

IEC 728/01

*Dimensions in millimetres*

The centre distance and the design of the contacts as well as the dimensions and the design of the front part shall be such that

- the connector will enter, to the full depth, the gauge of figure 2 and will not enter gauges of figures 6, 7 and 8;
- the connector complies with the requirements of 16 and 17;
- the thickness of the insulation surrounding the contacts is not less than 1,5 mm.

The outline 1) of the front part shall not be exceeded or decreased, at any point, within a distance of 10,5 mm from the engagement face.

The outline 2) of the rear part shall not be exceeded in any section perpendicular to the axis of the connector, except that, for connectors with lateral cord entry and for those combined with other accessories, this limitation does not apply in the direction of the axis of the cord or of the actuating member.

The contacts may be floating.

*The sketches are not intended to govern design, except as regards the dimensions shown.*

STANDARD SHEET C2

0,2 A 250 V APPLIANCE INLET  
FOR CLASS II EQUIPMENT  
FOR COLD CONDITIONS

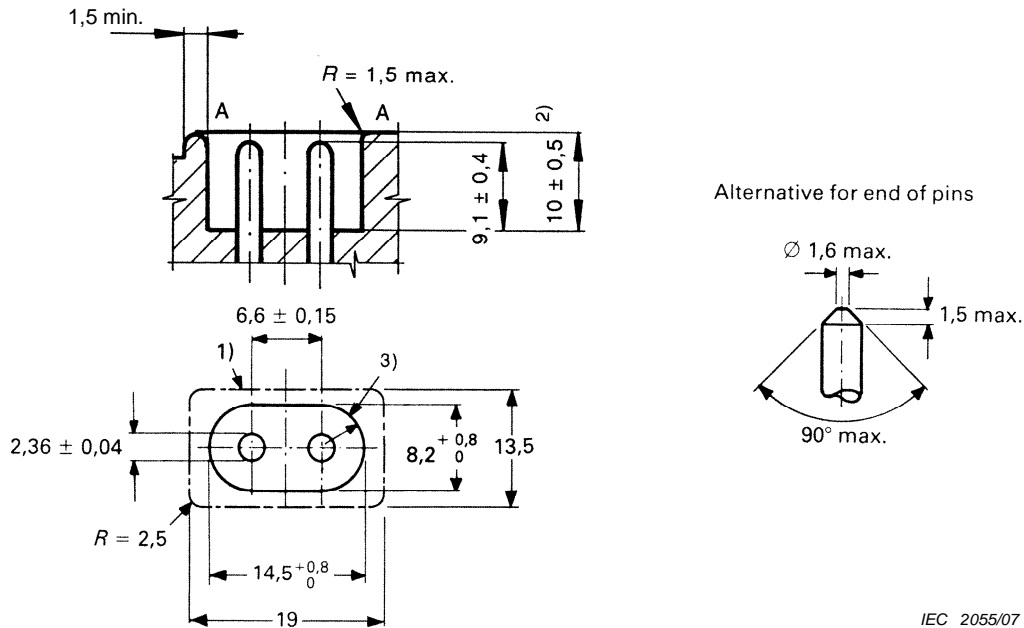

IEC 2055/07

Dimensions in millimetres

The ends of the pins may be spherical or conical of the form shown.

The outline 3) shall be at a distance of 10 mm ± 0,5 mm from the engagement face at the bottom of the inlet. The distance from the engagement face at the bottom of the inlet to plane A-A may, however, be less elsewhere within the area 1). Plane A-A need not necessarily be extended to the outline of area 1). A rim which is slightly rounded on top is allowed around the recess if it has a thickness of at least 1,5 mm. Retaining devices or parts thereof may be within the area 1). No other parts of the inlet may protrude beyond plane A-A.

2) For appliance inlets arranged countersunk in the outer surface of equipment, and if this surface is curved or inclined with respect to the axis of the appliance inlet, this dimension shall be not more than 10,5 mm; the minimum shall be determined in accordance with 9.5.

The sketches are not intended to govern design, except as regards the dimensions shown.

## STANDARD SHEET C5

2,5 A 250 V CONNECTOR  
FOR CLASS I EQUIPMENT  
FOR COLD CONDITIONS  
(non-rewirable only)

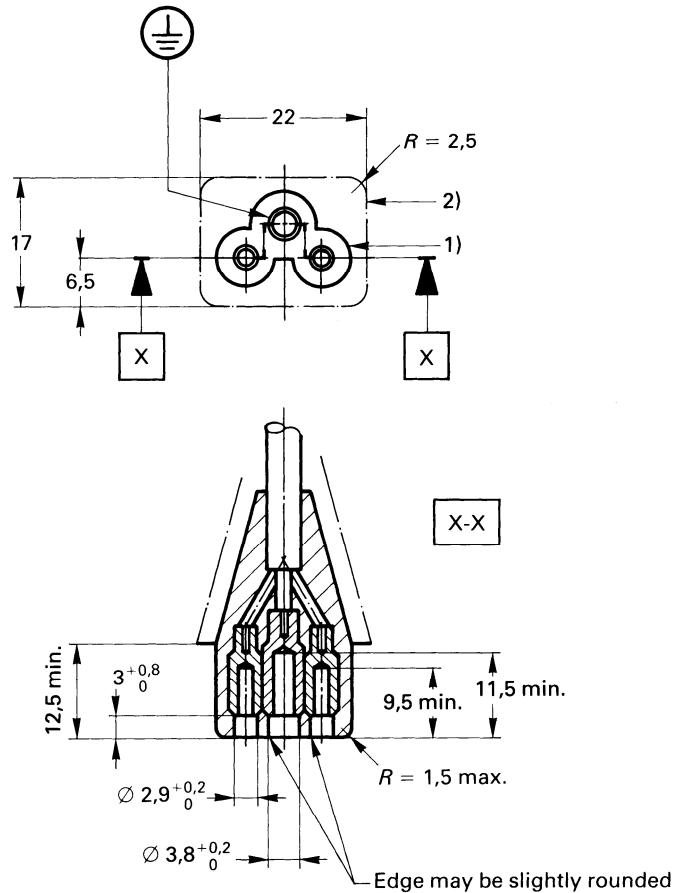

IEC 730/01

Dimensions in millimetres

The centre distance and the design of the contacts as well as the dimensions and the design of the front part shall be such that:

- the connector will enter, to the full depth, the gauge of figure 4 and will not enter gauges of figure 7;
- the connector complies with the requirements of 16 and 17;
- the thickness of the insulation surrounding the contacts is not less than 1,5 mm.

The outline 1) of the front part shall not be exceeded or decreased, at any point, within a distance of 12,5 mm from the engagement face.

The outline 2) of the rear part shall not be exceeded in any section perpendicular to the axis of the connector, except that, for connectors with lateral cord entry and for those combined with other accessories, this limitation does not apply in the direction of the axis of the cord or of the actuating member.

The contacts may be floating.

*The sketches are not intended to govern design, except as regards the dimensions shown.*

For the symbols indicating the tolerance of form or of position, see ISO 1101.

STANDARD SHEET C6

2,5 A 250 V APPLIANCE INLET  
FOR CLASS I EQUIPMENT  
FOR COLD CONDITIONS

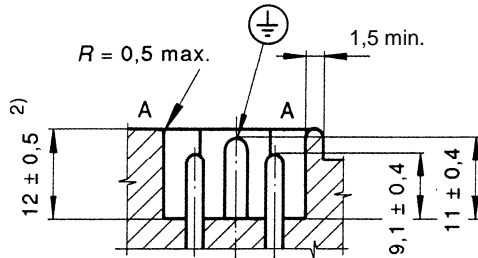

Alternatives for end of pins

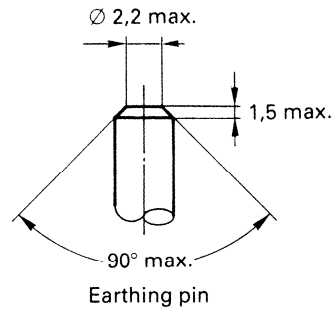

Earthing pin

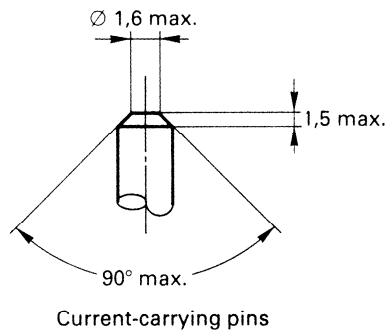
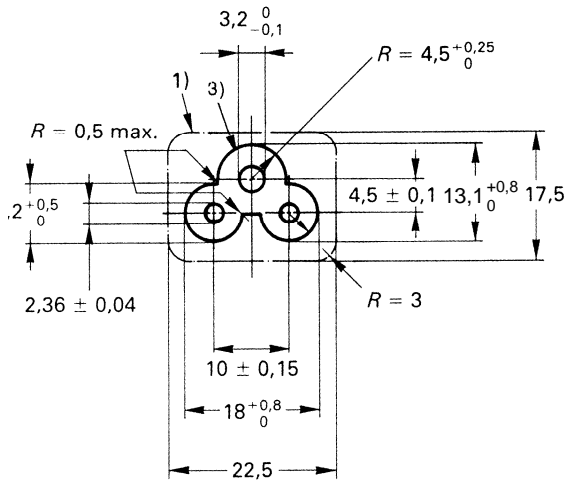

Current-carrying pins

IEC 2056/07

Dimensions in millimetres

The ends of the pins may be spherical or conical of the form shown.

The outline 3) shall be at a distance of 12 mm ± 0,5 mm from the engagement face at the bottom of the inlet. The distance from the engagement face at the bottom of the inlet to plane A-A may, however, be less elsewhere within the area 1). Plane A-A need not necessarily be extended to the outline of area 1). A rim which is slightly rounded on top is allowed around the recess if it has a thickness of at least 1,5 mm. Retaining devices or parts thereof may be within the area 1). No other parts of the inlet may protrude beyond plane A-A.

2) For appliance inlets arranged countersunk in the outer surface of equipment, and if this surface is curved or inclined with respect to the axis of the appliance inlet, this dimension shall be not more than 12,5 mm; the minimum shall be determined in accordance with 9.5.

The sketches are not intended to govern design, except as regards the dimensions shown.



## STANDARD SHEET C7

2,5 A 250 V CONNECTOR  
FOR CLASS II EQUIPMENT  
FOR COLD CONDITIONS  
(non-rewirable only)

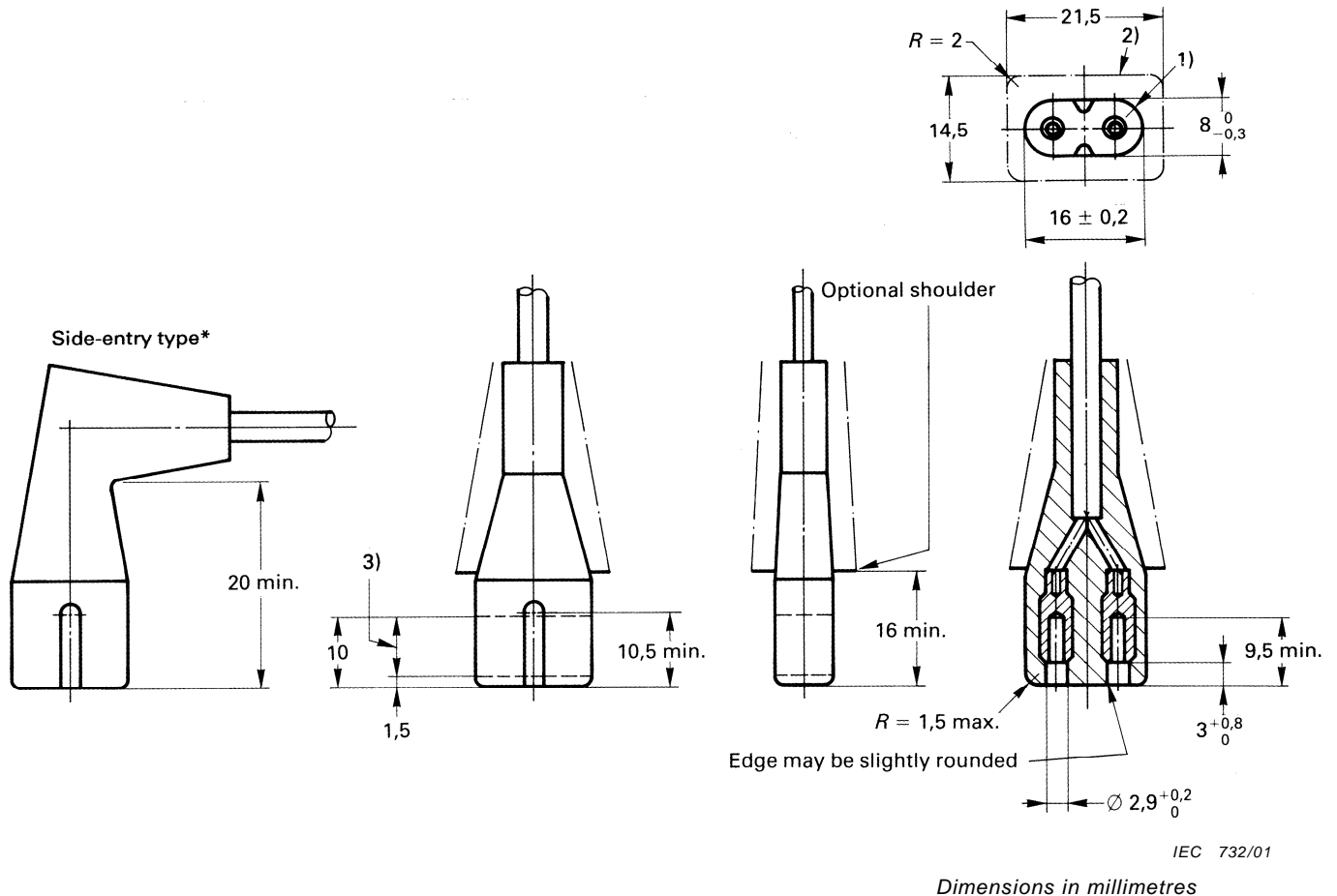

The centre distance and the design of the contacts as well as the dimensions and the design of the front part shall be such that

- the connector will enter, to the full depth, the gauge of figures 5 and 5A and will not enter gauges of figures 7 and 8;
- the connector complies with the requirements of 16 and 17;
- the thickness of the insulation surrounding the contacts is not less than 1,5 mm.

The outline 1) of the front part shall not be exceeded or decreased, at any point, within a distance of 16 mm from the engagement face.

The outline 2) of the rear part shall not be exceeded in any section perpendicular to the axis of the connector, except that, for connectors with lateral cord entry and for those combined with other accessories, this limitation does not apply in the direction of the axis of the cord or of the actuating member.

Within the area 3) the connector shall comply with the requirements of 23.6.

The contacts may be floating.

*The sketches are not intended to govern design, except as regards the dimensions shown.*

\* This sketch is intended only to indicate the dimension 20 mm min. from the engagement face to the "tail" of the connector. It does not preclude constructions of side-entry connectors in which the axis of the cord is not in the plane through the axial axes of the socket contacts (as shown) but perpendicular to that plane.

STANDARD SHEET C8

2,5 A 250 V APPLIANCE INLET  
FOR CLASS II EQUIPMENT  
FOR COLD CONDITIONS  
STANDARD TYPE\*

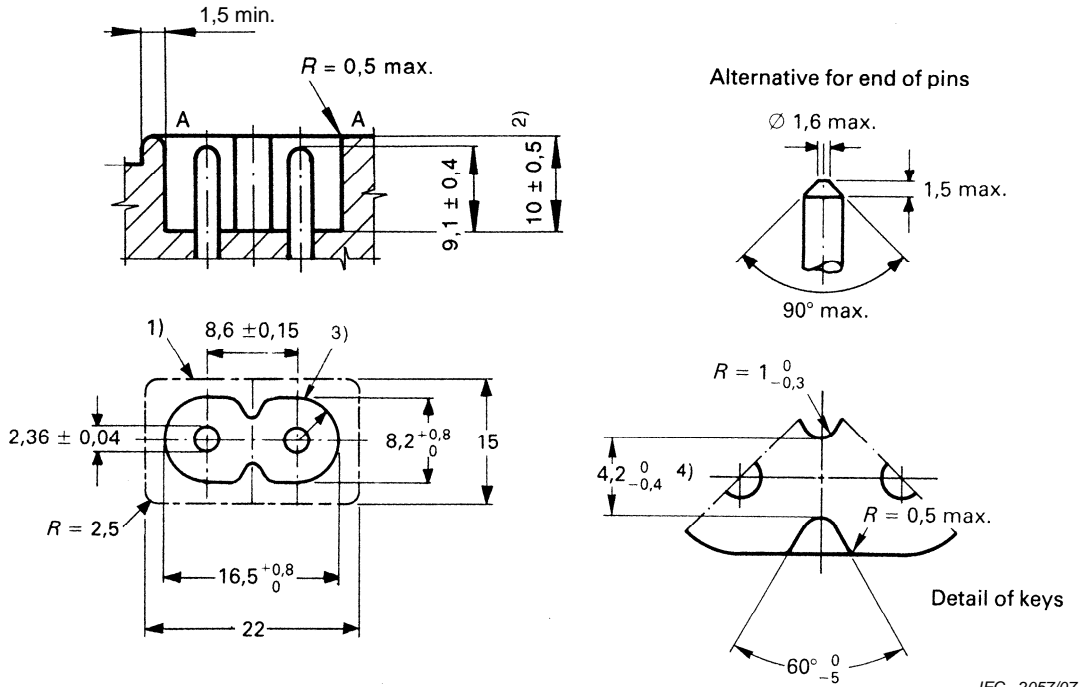

IEC 2057/07

Dimensions in millimetres

The ends of the pins may be spherical or conical of the form shown.

The outline 3) shall be at a distance of 10 mm ± 0,5 mm from the engagement face at the bottom of the inlet. The distance from the engagement face at the bottom of the inlet to plane A-A may, however, be less elsewhere within the area 1). Plane A-A need not necessarily be extended to the outline of area 1). A rim which is slightly rounded on top is allowed around the recess if it has a thickness of at least 1,5 mm. Retaining devices or parts thereof may be within the area 1). No other parts of the inlet may protrude beyond plane A-A.

2) For appliance inlets arranged countersunk in the outer surface of equipment, and if this surface is curved or inclined with respect to the axis of the appliance inlet, this dimension shall be not more than 10,5 mm; the minimum shall be determined in accordance with 9.5.

4) Also to be checked by means of the gauge of figure 9.

\* This type of appliance inlet is standardized because of existing types of connectors with 10,5 mm distance between engagement face and shoulder.

POSITIONS OF SWITCH CAMS  
(applicable to appliance inlets to standard sheets C8, C8A and C8B)

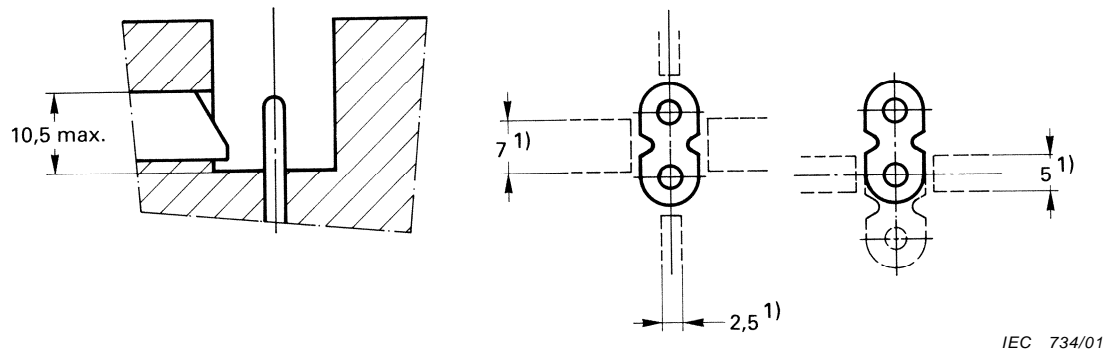

The operation of the switch shall be effected 1,5 mm before full engagement of the connector

For appliance inlets to standard sheets C8 and C8A

For appliance inlets to standard sheet C8B

1) Minimum dimensions of the switch cams. A key is not required where a switch cam is situated.  
The sketches are not intended to govern design, except as regards the dimensions shown.

STANDARD SHEET C8A

2,5 A 250 V APPLIANCE INLET  
FOR CLASS II EQUIPMENT  
FOR COLD CONDITIONS

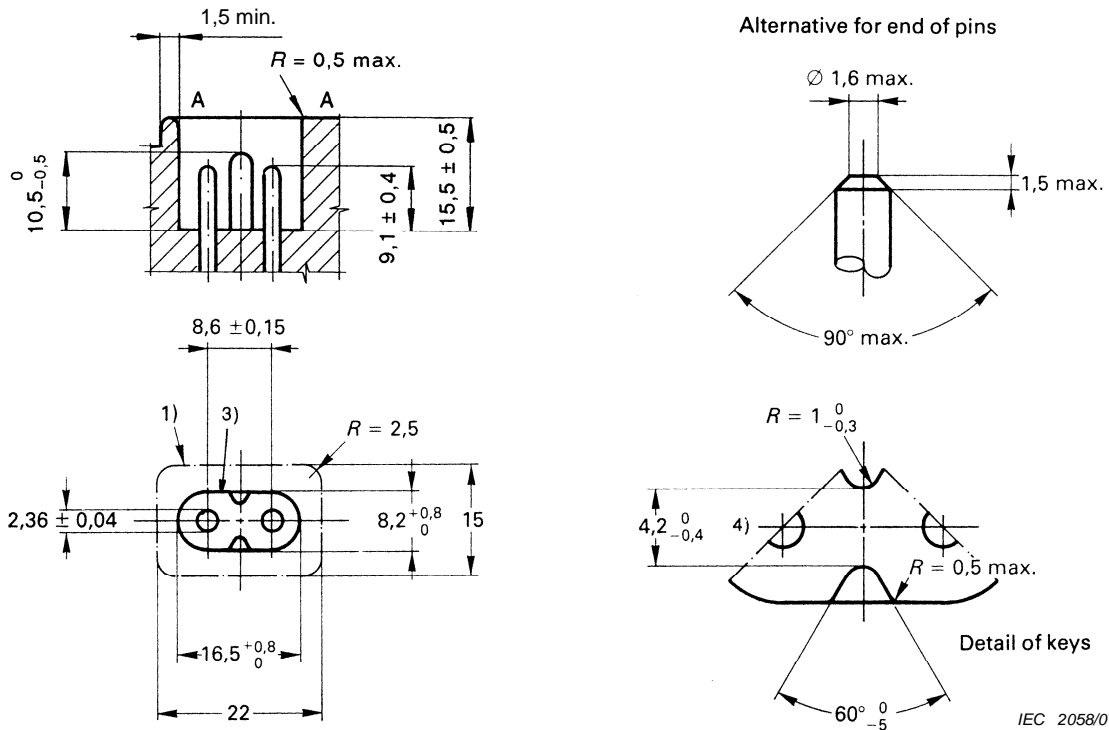

IEC 2058/07

Dimensions in millimetres

The ends of the pins may be spherical or conical of the form shown.

The outline 3) shall be at a distance of 15,5 mm ± 0,5 mm from the engagement face at the bottom of the inlet. The distance from the engagement face at the bottom of the inlet to plane A-A may, however, be less elsewhere within the area 1). Plane A-A need not necessarily be extended to the outline of area 1). A rim which is slightly rounded on top is allowed around the recess if it has a thickness of at least 1,5 mm. Retaining devices or parts thereof may be within the area 1). No other parts of the inlet may protrude beyond plane A-A.

The appliance inlet shall not be mounted in the outer surface of equipment which is curved or inclined with respect to the axis of the appliance inlet.

For the position of switch cams, see standard sheet C8.

2) Also to be checked by means of the gauge of figure 9.

The sketches are not intended to govern design, except as regards the dimension shown.



STANDARD SHEET C9

6 A 250 V CONNECTOR  
FOR CLASS II EQUIPMENT  
FOR COLD CONDITIONS  
(non-rewirable only)

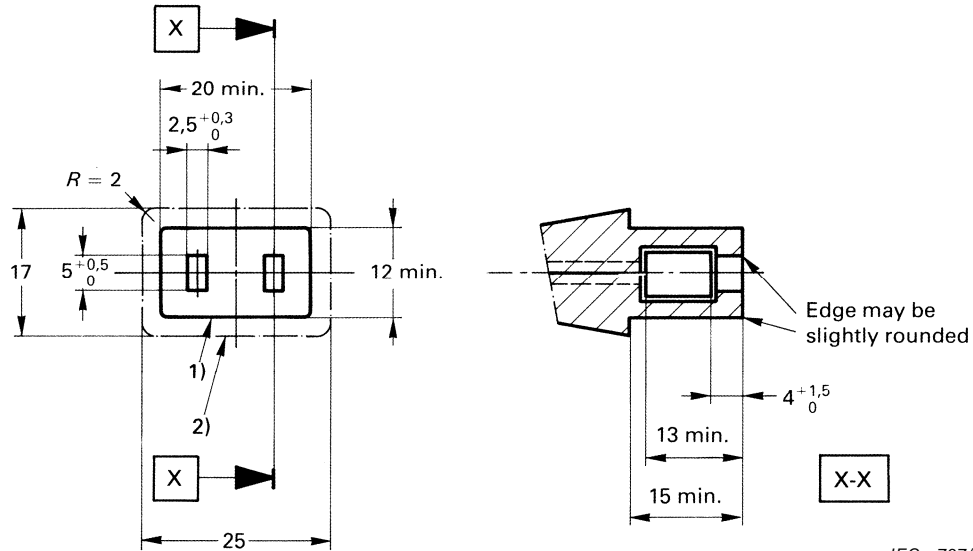

IEC 737/01  
Dimensions in millimetres

The centre distance and the design of the contacts as well as the dimensions and the design of the front part shall be such that

- the connector will enter, to the full depth, an appliance inlet to standard sheet C10, having the minimum length and breadth;
- the connector complies with the requirements of 16 and 17;
- the thickness of the insulation surrounding the contacts is not less than 1,5 mm.

The outline 1) of the front part shall not be exceeded or decreased, at any point, within a distance of 15 mm from the engagement face.

The outline 2) of the rear part shall not be exceeded in any section perpendicular to the axis of the connector, except that, for connectors with lateral cord entry and for those combined with other accessories, this limitation does not apply in the direction of the axis of the cord or of the actuating member.

The contacts may be floating.

*The sketches are not intended to govern design, except as regards the dimensions shown.*

For the symbols indicating the tolerance of form or of position, see ISO 1101.

## STANDARD SHEET C10

6 A 250 V APPLIANCE INLET  
FOR CLASS II EQUIPMENT  
FOR COLD CONDITIONS

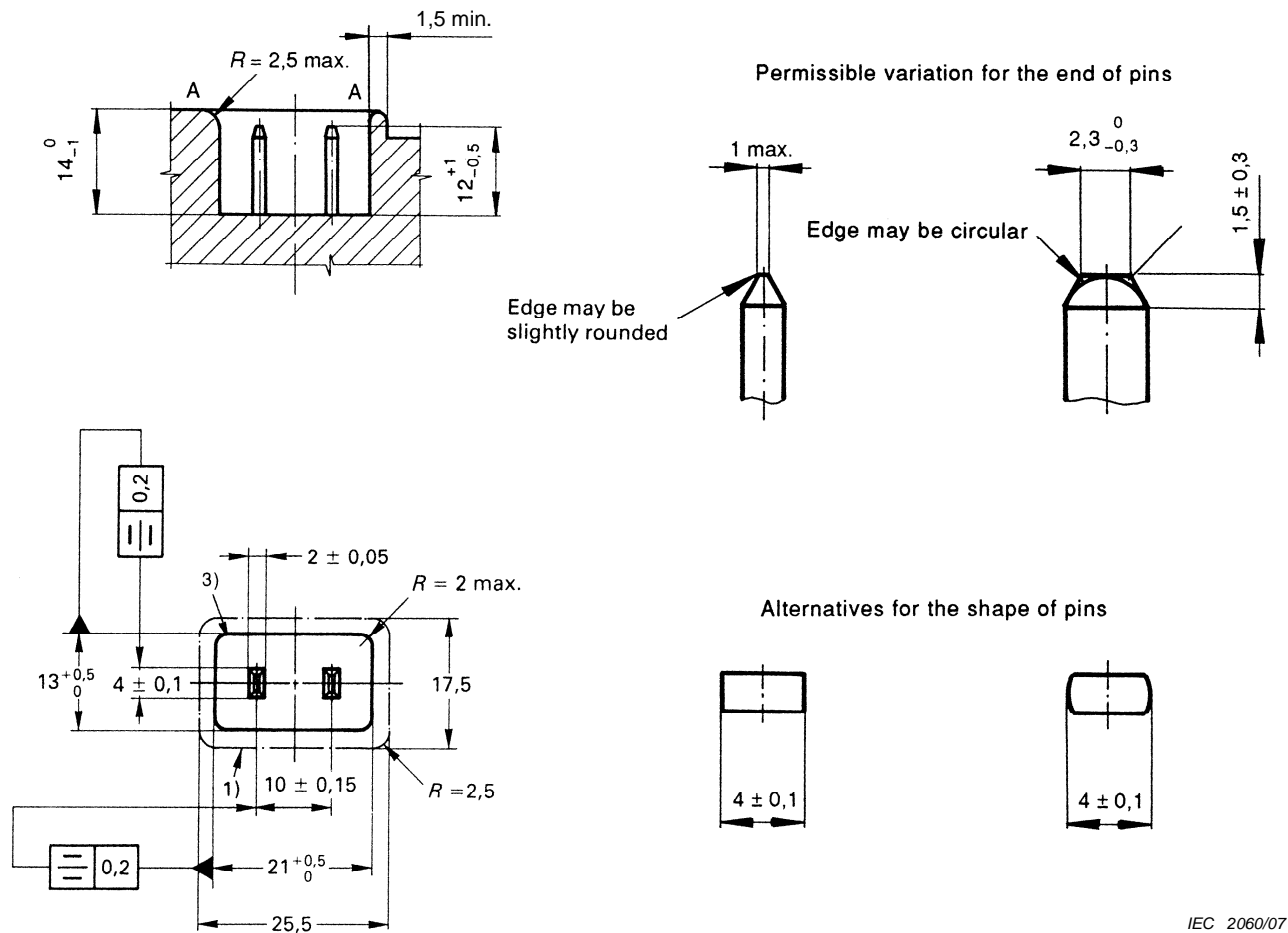

Dimensions in millimetres

The outline 3) shall be at a distance of  $14_{-1}^0$  mm from the engagement face at the bottom of the inlet. The distance from the engagement face at the bottom of the inlet to plane A-A may, however, be less elsewhere within the area 1). Plane A-A need not necessarily be extended to the outline of area 1). A rim which is slightly rounded on top is allowed around the recess if it has a thickness of at least 1,5 mm. Retaining devices or parts thereof may be within the area 1). No other parts of the inlet may protrude beyond plane A-A.

2) For appliance inlets arranged countersunk in the outer surface of equipment and if this surface is curved or inclined with respect to the axis of the appliance inlet, this dimension shall be not more than 14 mm; the minimum shall be determined in accordance with 9.5.

*The sketches are not intended to govern design, except as regards the dimension shown.*

For the symbols indicating the tolerance of form or of position, see ISO 1101.

STANDARD SHEET C13

10 A 250 V CONNECTOR  
FOR CLASS I EQUIPMENT  
FOR COLD CONDITIONS

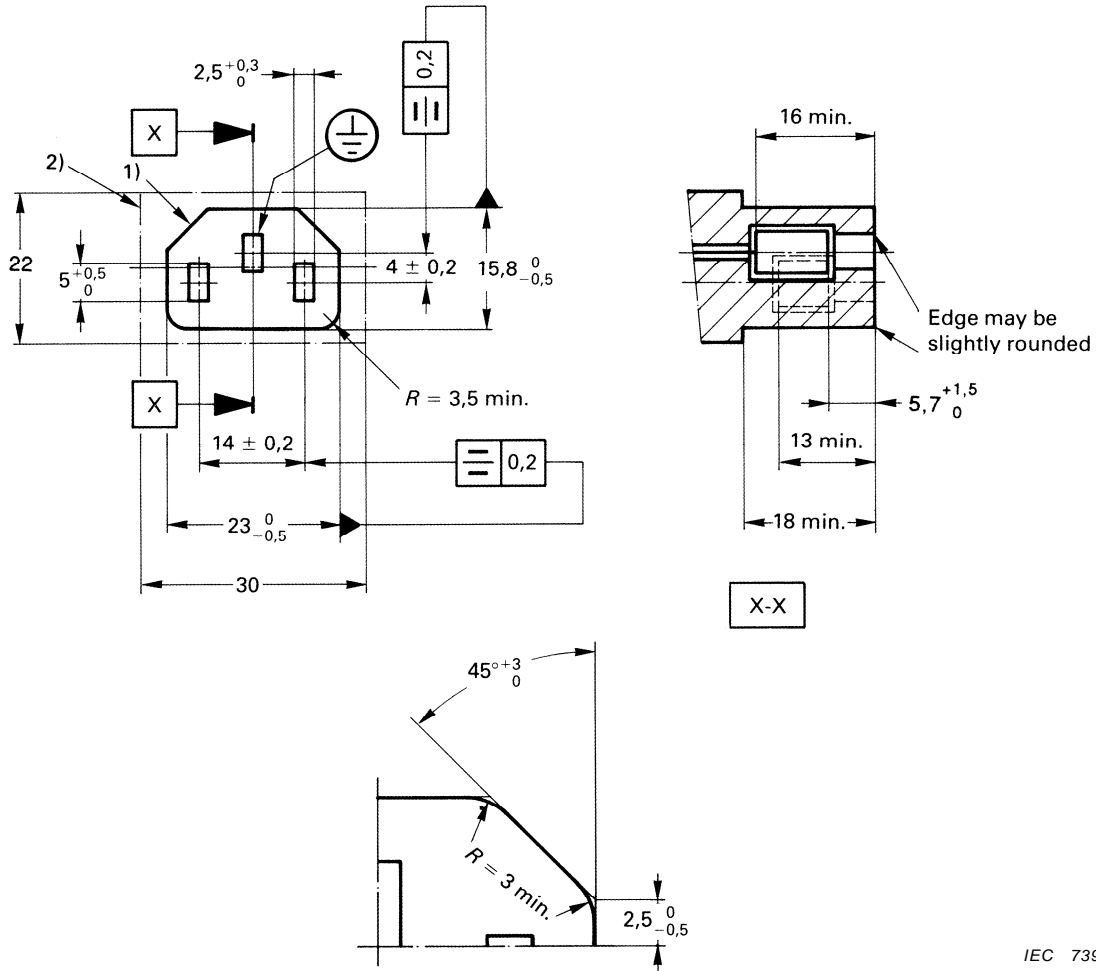

IEC 739/01

Dimensions in millimetres

The outline 1) of the front part shall not be exceeded or decreased, at any point, within a distance of 18 mm from the engagement face.

The outline 2) of the rear part shall not be exceeded in any section perpendicular to the axis of the connector, except that, for connectors with lateral cord entry and for those combined with other accessories, this limitation does not apply in the direction of the axis of the cord or of the actuating member.

The contact may be floating.

*The sketches are not intended to govern design, except as regards the dimensions shown.*

For the symbols indicating the tolerance of form or of position, see ISO 1101.





STANDARD SHEET C15

10 A 250 V CONNECTOR  
FOR CLASS I EQUIPMENT  
FOR HOT CONDITIONS

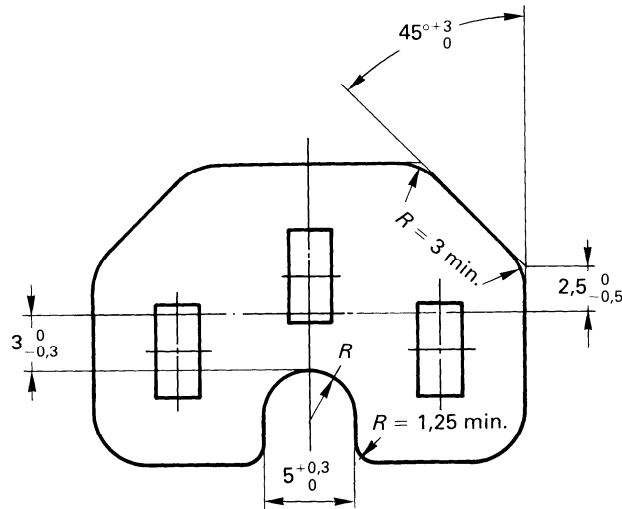
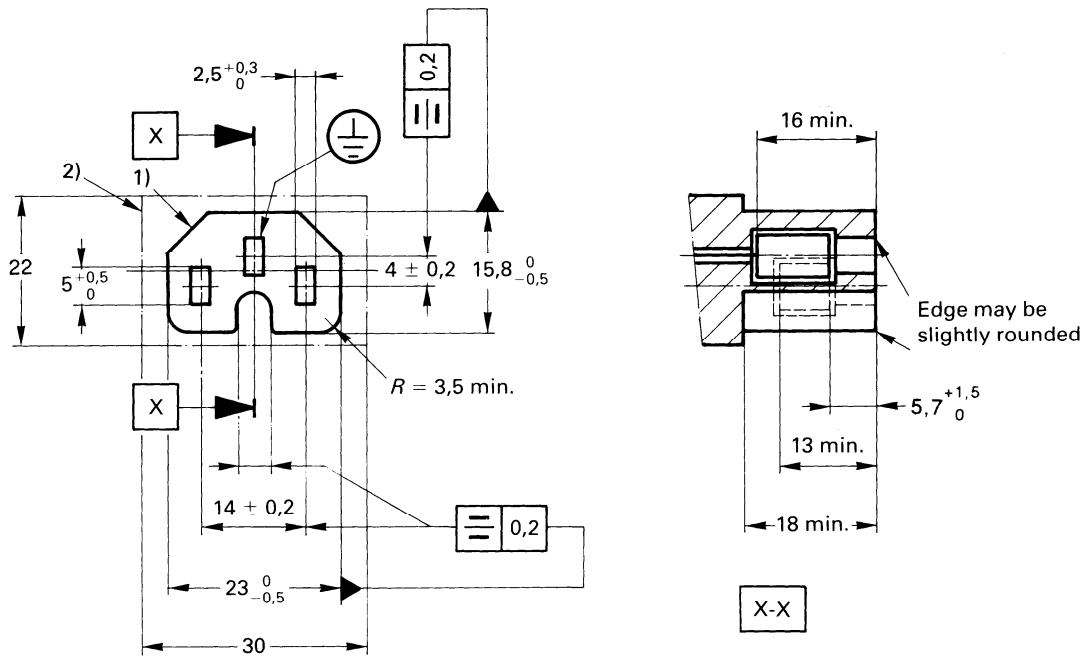

IEC 741/01

Dimensions in millimetres

The outline 1) of the front part shall not be exceeded or decreased, at any point, within a distance of 18 mm from the engagement face.

The outline 2) of the rear part shall not be exceeded in any section perpendicular to the axis of the connector, except that, for connectors with lateral cord entry and for those combined with other accessories, this limitation does not apply in the direction of the axis of the cord or of the actuating member.

The contact may be floating.

The sketches are not intended to govern design, except as regards the dimensions shown.

For the symbols indicating the tolerance of form or of position, see ISO 1101.

## STANDARD SHEET C15A

10 A 250 V CONNECTOR  
FOR CLASS I EQUIPMENT  
FOR VERY HOT CONDITIONS

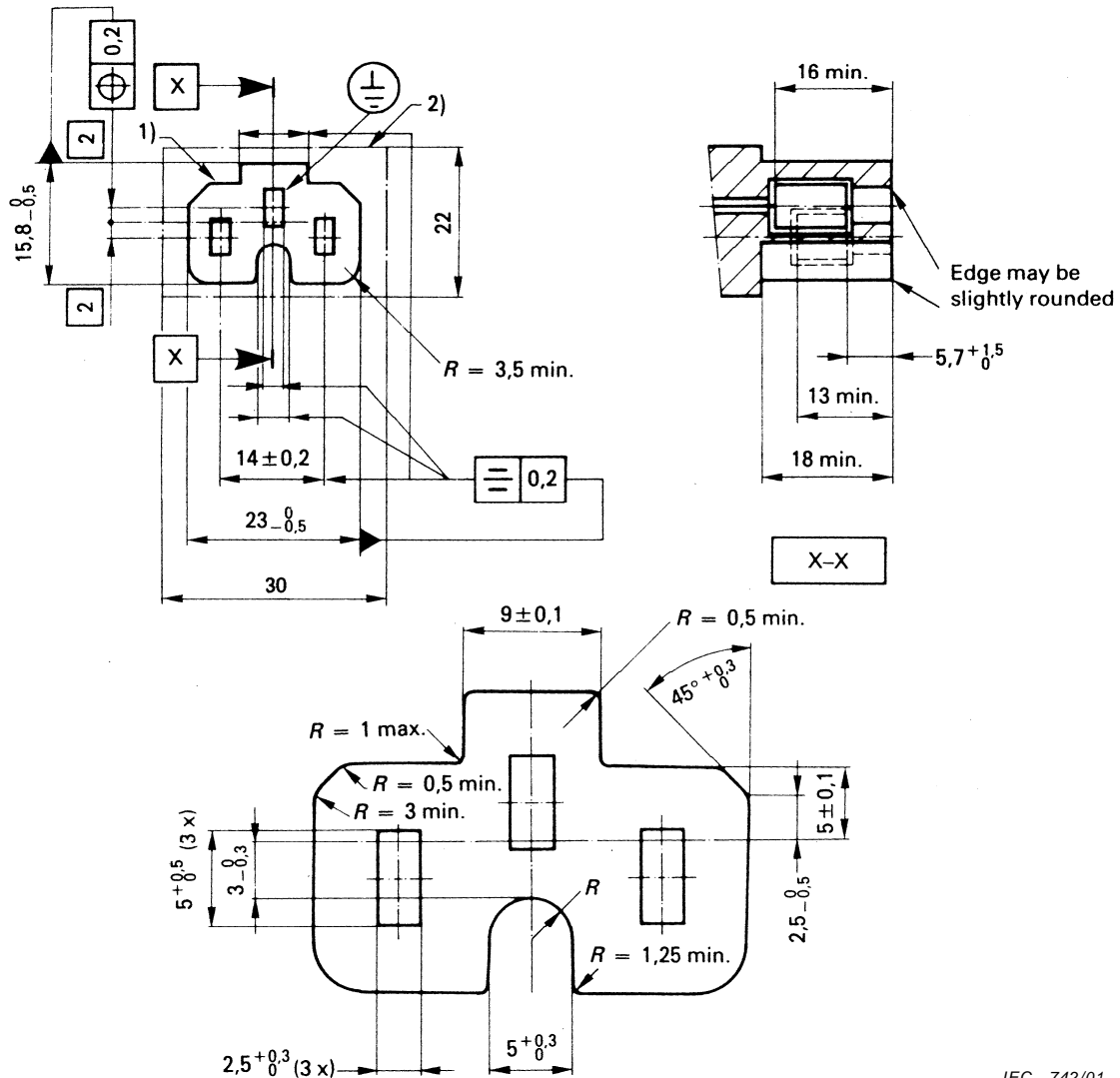

IEC 742/01

Dimensions in millimetres

The outline 1) of the front part shall not be exceeded or decreased, at any point, within a distance of 18 mm from the engagement face.

The outline 2) of the rear part shall not be exceeded in any section perpendicular to the axis of the connector, except that, for connectors with lateral cord entry and for those combined with other accessories, this limitation does not apply in the direction of the axis of the cord or of the actuating member.

The contact may be floating.

*The sketches are not intended to govern design, except as regards the dimensions shown.*

For the symbols indicating the tolerance of form or of position, see ISO 1101.

STANDARD SHEET C16

10 A 250 V APPLIANCE INLET  
FOR CLASS I EQUIPMENT  
FOR HOT CONDITIONS

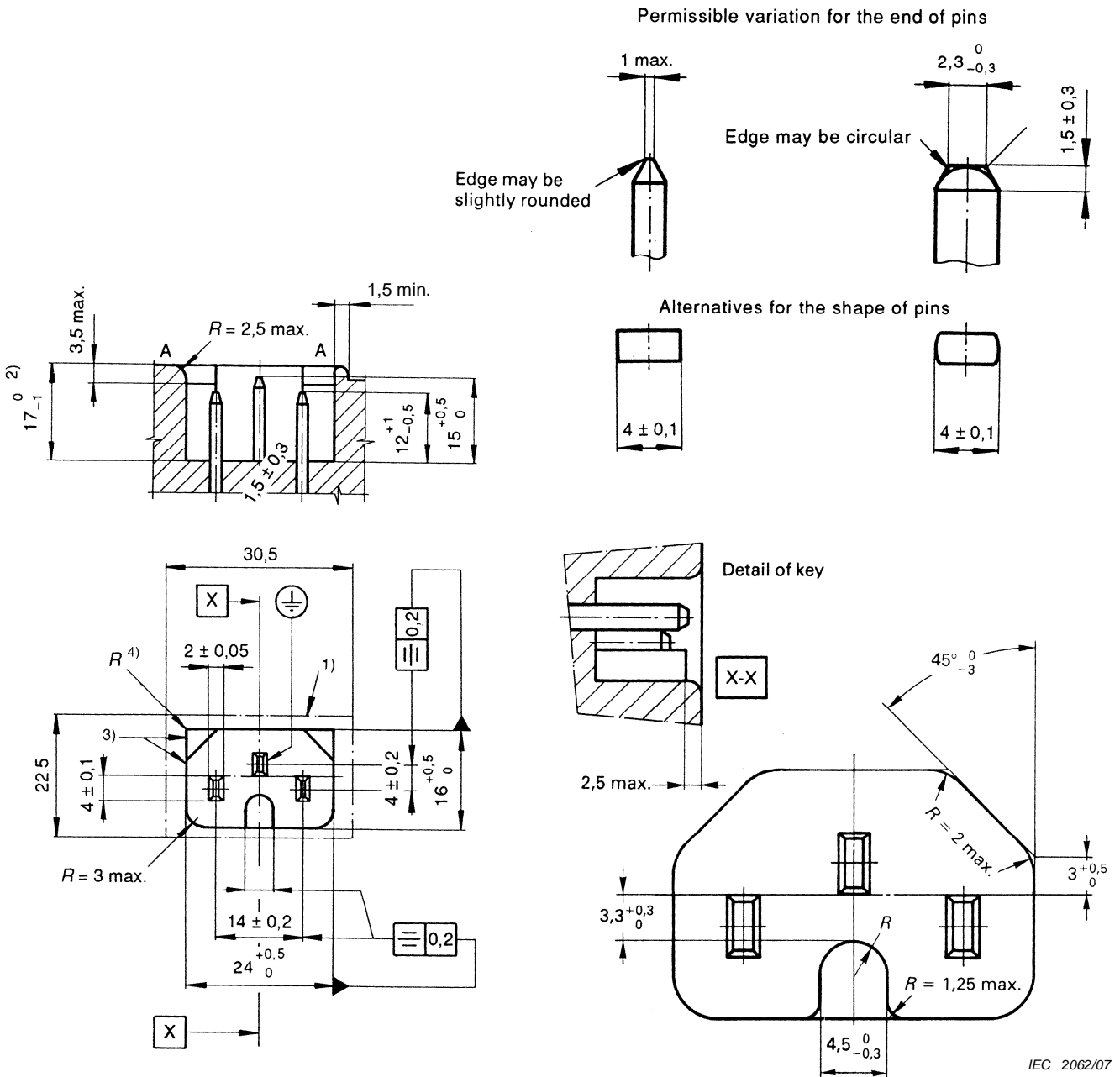

IEC 2062/07

Dimensions in millimetres

The outline 3) shall be at a distance of  $17_{-1}^0$  mm from the engagement face at the bottom of the inlet. The distance from the engagement face at the bottom of the inlet to plane A-A may, however, be less elsewhere within the area 1). Plane A-A need not necessarily be extended to the outline of area 1). A rim which is slightly rounded on top is allowed around the recess if it has a thickness of at least 1,5 mm. Retaining devices or parts thereof may be within the area 1). No other parts of the inlet may protrude beyond plane A-A.

4) No radius is specified for the right-angled corners of outline 3). Their shape may be rounded, provided they remain outside of the angled internal corners which are optionally recessed to a maximum of 3,5 mm.

2) For appliance inlets arranged countersunk in the outer surface of equipment and if this surface is curved or inclined with respect to the axis of the appliance inlet, this dimension shall be not more than 17 mm; the minimum shall be determined in accordance with 9.5.

The sketches are not intended to govern design, except as regards the dimension shown.

For the symbols indicating the tolerance of form or of position, see ISO 1101.

## STANDARD SHEET C16A

10 A 250 V APPLIANCE INLET  
FOR CLASS I EQUIPMENT  
FOR VERY HOT CONDITIONS

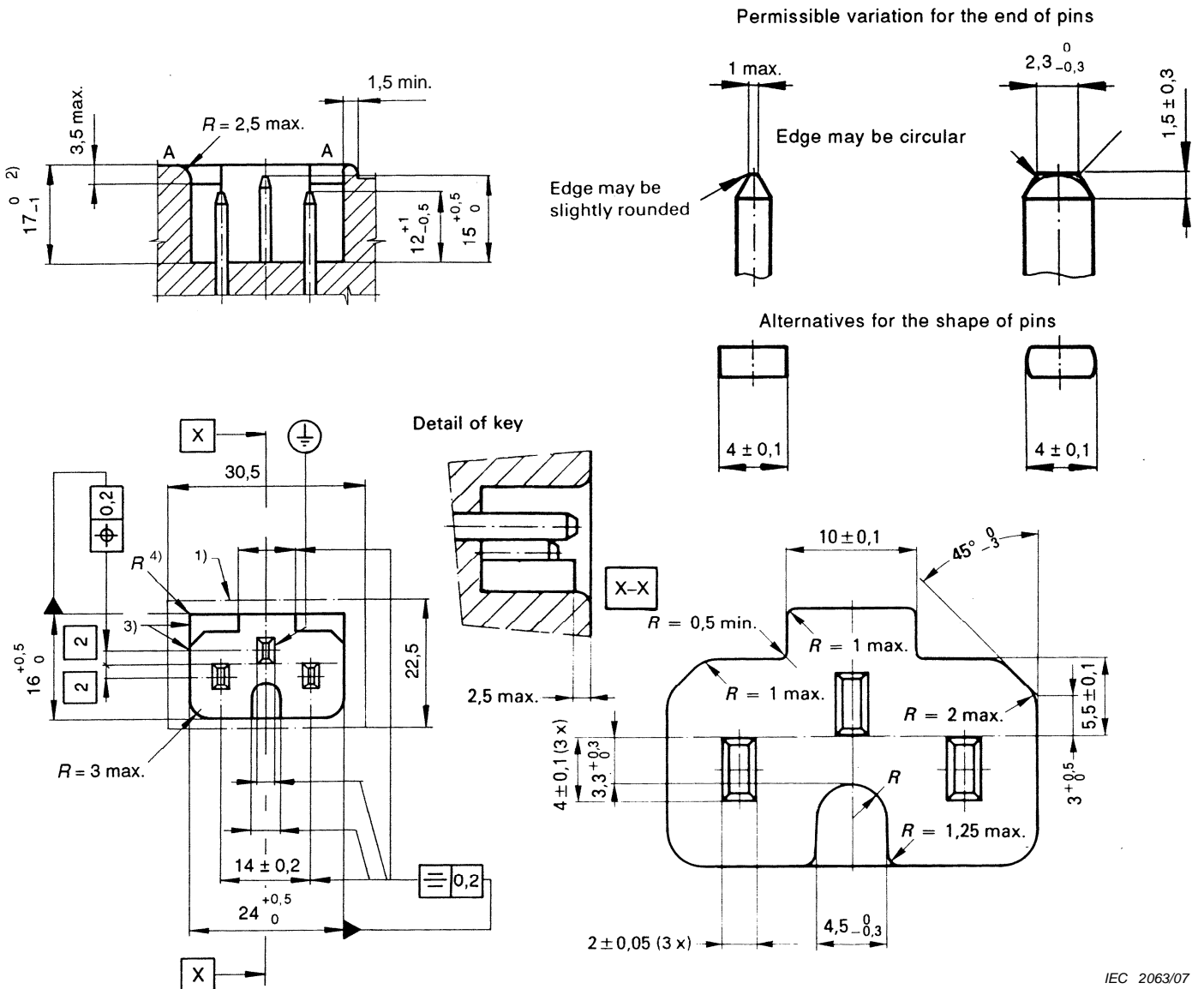

Dimensions in millimetre

The outline 3) shall be at a distance of  $17 \begin{smallmatrix} 0 \\ -1 \end{smallmatrix}$  mm from the engagement face at the bottom of the inlet. The distance from the engagement face at the bottom of the inlet to plane A-A may, however, be less elsewhere within the area 1). Plane A-A need not necessarily be extended to the outline of area 1). A rim which is slightly rounded on top is allowed around the recess if it has a thickness of at least 1,5 mm. Retaining devices or parts thereof may be within the area 1). No other parts of the inlet may protrude beyond plane A-A.

4) No radius is specified for the right-angled corners of outline 3). Their shape may be rounded, provided they remain outside of the angled internal corners which are optionally recessed to a maximum of 3,5 mm.

2) For appliance inlets arranged countersunk in the outer surface of equipment and if this surface is curved or inclined with respect to the axis of the appliance inlet, this dimension shall be not more than 17 mm; the minimum shall be determined in accordance with 9.5.

The sketches are not intended to govern design, except as regards the dimension shown.

For the symbols indicating the tolerance of form or of position, see ISO 1101.



## STANDARD SHEET C18

10 A 250 V APPLIANCE INLET  
FOR CLASS II EQUIPMENT  
FOR COLD CONDITIONS

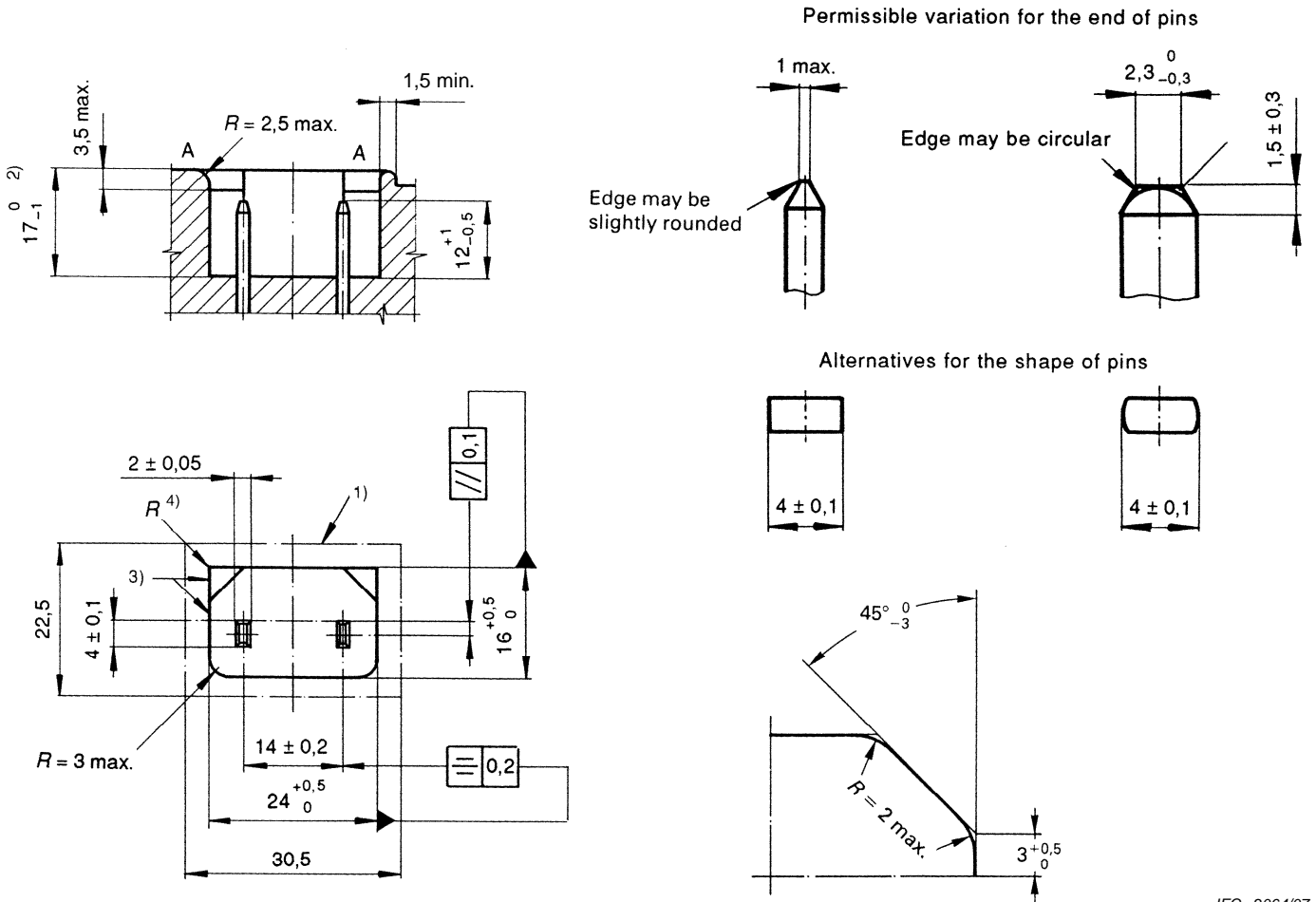

IEC 2064/07

Dimensions in millimetres

The outline 3) shall be at a distance of  $17 \begin{matrix} 0 \\ -1 \end{matrix}$  mm from the engagement face at the bottom of the inlet. The distance from the engagement face at the bottom of the inlet to plane A-A may, however, be less elsewhere within the area 1). Plane A-A need not necessarily be extended to the outline of area 1). A rim which is slightly rounded on top is allowed around the recess if it has a thickness of at least 1,5 mm. Retaining devices or parts thereof may be within the area 1). No other parts of the inlet may protrude beyond plane A-A.

4) No radius is specified for the right-angled corners of outline 3). Their shape may be rounded, provided they remain outside of the angled internal corners which are optionally recessed to a maximum of 3,5 mm.

2) For appliance inlets arranged countersunk in the outer surface of equipment and if this surface is curved or inclined with respect to the axis of the appliance inlet, this dimension shall be not more than 17 mm; the minimum shall be determined in accordance with 9.5.

*The sketches are not intended to govern design, except as regards the dimension shown.*

For the symbols indicating the tolerance of form or of position, see ISO 1101.





## STANDARD SHEET C20

16 A 250 V APPLIANCE INLET  
FOR CLASS I EQUIPMENT  
FOR COLD CONDITIONS

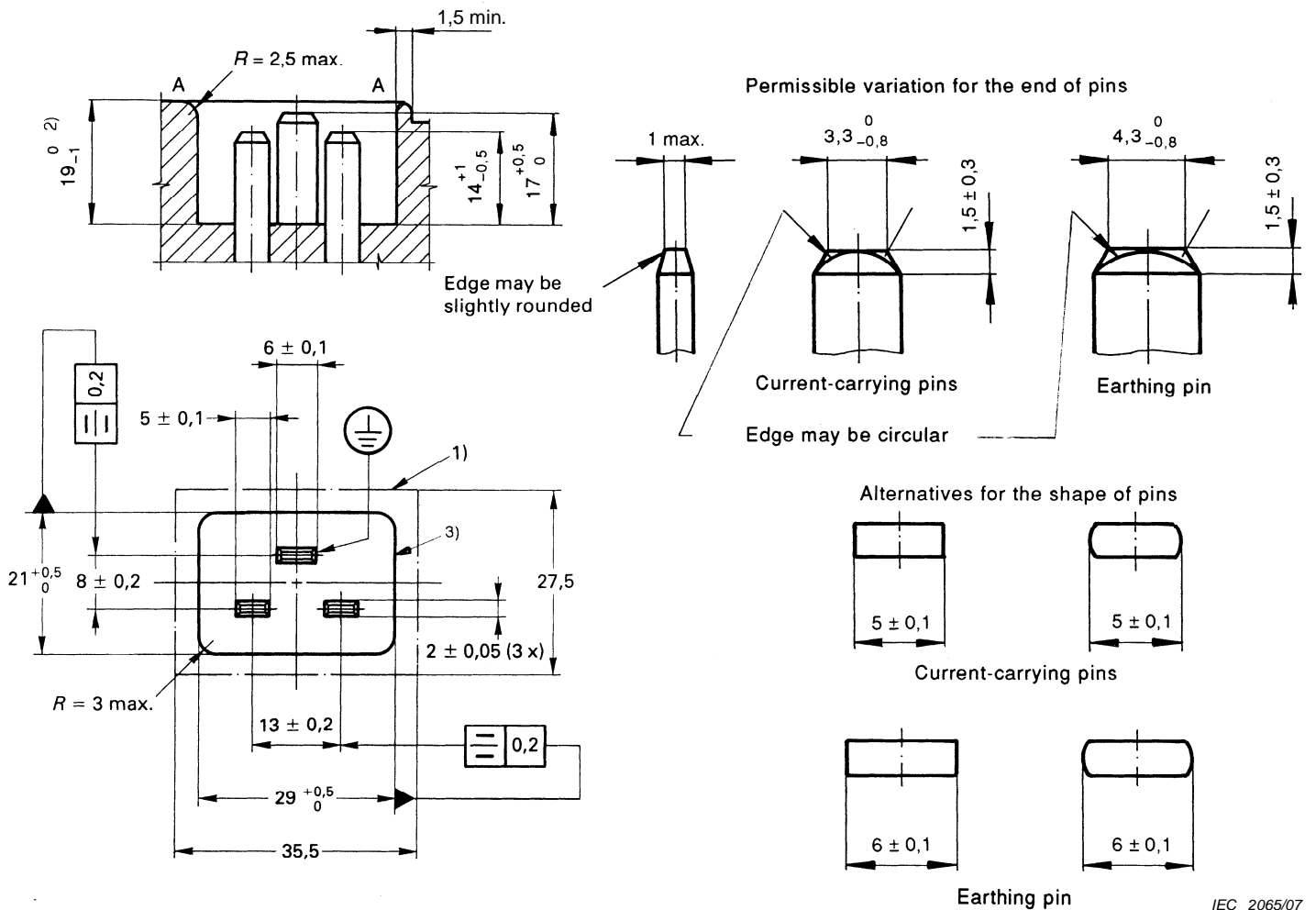

Dimensions in millimetres

The outline 3) shall be at a distance of  $19 \begin{smallmatrix} 0 \\ -1 \end{smallmatrix}$  mm from the engagement face at the bottom of the inlet. The distance from the engagement face at the bottom of the inlet to plane A-A may, however, be less elsewhere within the area 1). Plane A-A need not necessarily be extended to the outline of area 1). A rim which is slightly rounded on top is allowed around the recess if it has a thickness of at least 1,5 mm. Retaining devices or parts thereof may be within the area 1). No other parts of the inlet may protrude beyond plane A-A.

2) For appliance inlets arranged countersunk in the outer surface of equipment and if this surface is curved or inclined with respect to the axis of the appliance inlet, this dimension shall be not more than 19 mm; the minimum shall be determined in accordance with 9.5.

The sketches are not intended to govern design, except as regards the dimension shown.

For the symbols indicating the tolerance of form or of position, see ISO 1101.



## STANDARD SHEET C22

16 A 250 V APPLIANCE INLET  
FOR CLASS I EQUIPMENT  
FOR VERY HOT CONDITIONS

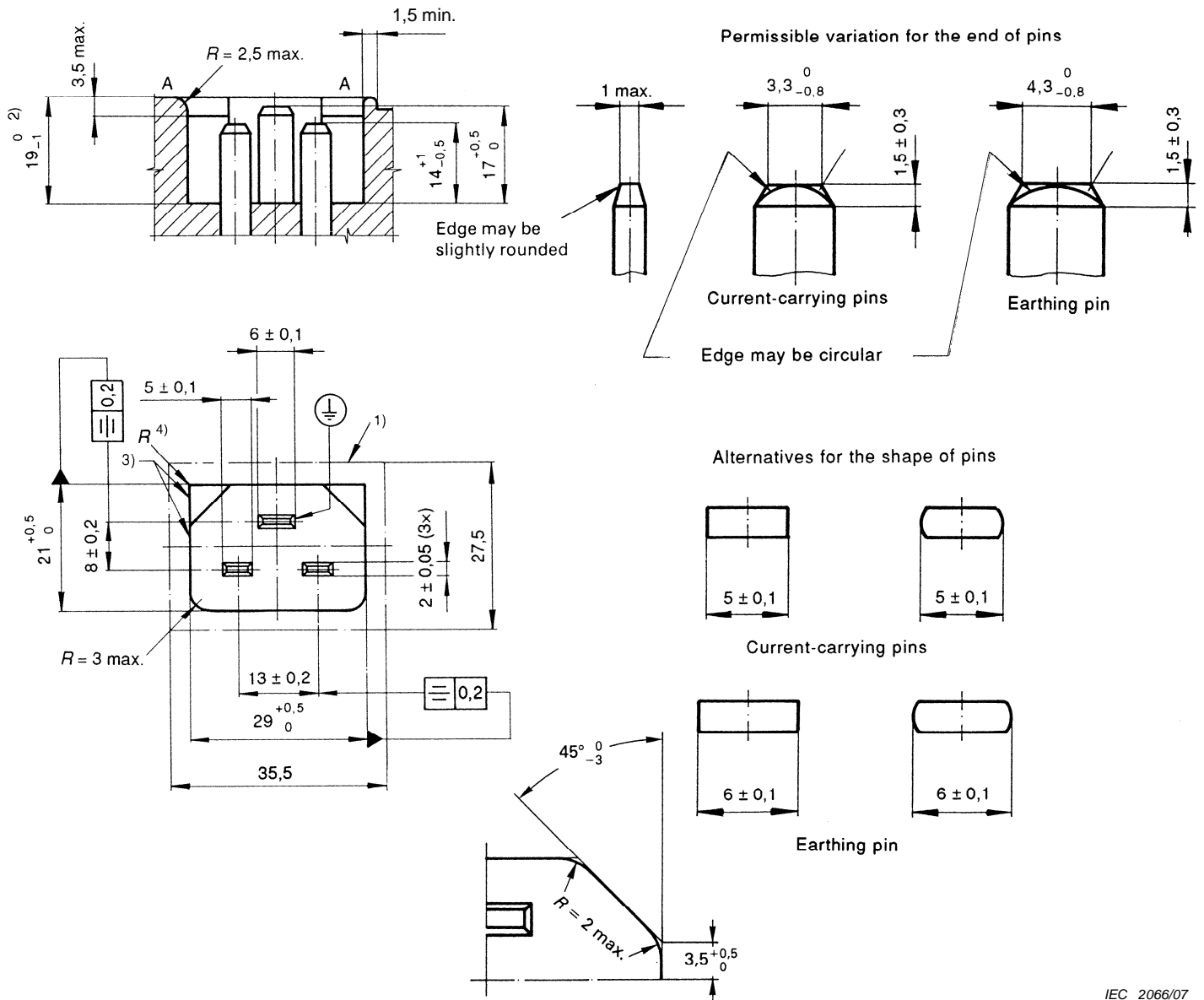

IEC 2066/07

Dimensions in millimetre

The outline 3) shall be at a distance of  $19_{-1}^0$  mm from the engagement face at the bottom of the inlet. The distance from the engagement face at the bottom of the inlet to plane A-A may, however, be less elsewhere within the area 1). Plane A-A need not necessarily be extended to the outline of area 1). A rim which is slightly rounded on top is allowed around the recess if it has a thickness of at least 1,5 mm. Retaining devices or parts thereof may be within the area 1). No other parts of the inlet may protrude beyond plane A-A.

No radius is specified for the right-angled corners of outline 3). Their shape may be rounded, provided they remain outside of the angled internal corners which are optionally recessed to a maximum of 3,5 mm.

2) For appliance inlets arranged countersunk in the outer surface of equipment and if this surface is curved or inclined with respect to the axis of the appliance inlet, this dimension shall be not more than 19 mm; the minimum shall be determined in accordance with 9.5.

*The sketches are not intended to govern design, except as regards the dimension shown.*

For the symbols indicating the tolerance of form or of position, see ISO 1101.

STANDARD SHEET C23

16 A 250 V CONNECTOR  
FOR CLASS II EQUIPMENT  
FOR COLD CONDITIONS  
(non-rewirable only)

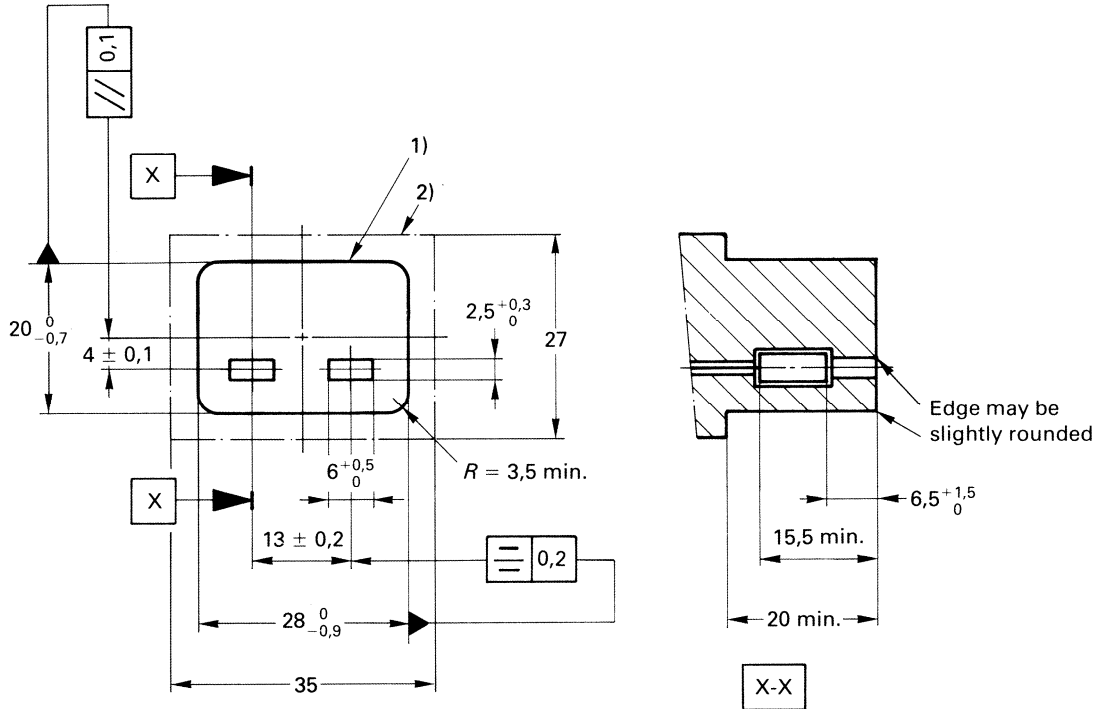

IEC 751/01

Dimensions in millimetres

The outline 1) of the front part shall not be exceeded or decreased, at any point, within a distance of 20 mm from the engagement face.

The outline 2) of the rear part shall not be exceeded in any section perpendicular to the axis of the connector, except that, for connectors with lateral cord entry and for those combined with other accessories, this limitation does not apply in the direction of the axis of the cord or of the actuating member.

The contact may be floating.

*The sketches are not intended to govern design, except as regards the dimensions shown.*

For the symbols indicating the tolerance of form or of position, see ISO 1101.

## STANDARD SHEET C24

16 A 250 V APPLIANCE INLET  
FOR CLASS II EQUIPMENT  
FOR COLD CONDITIONS

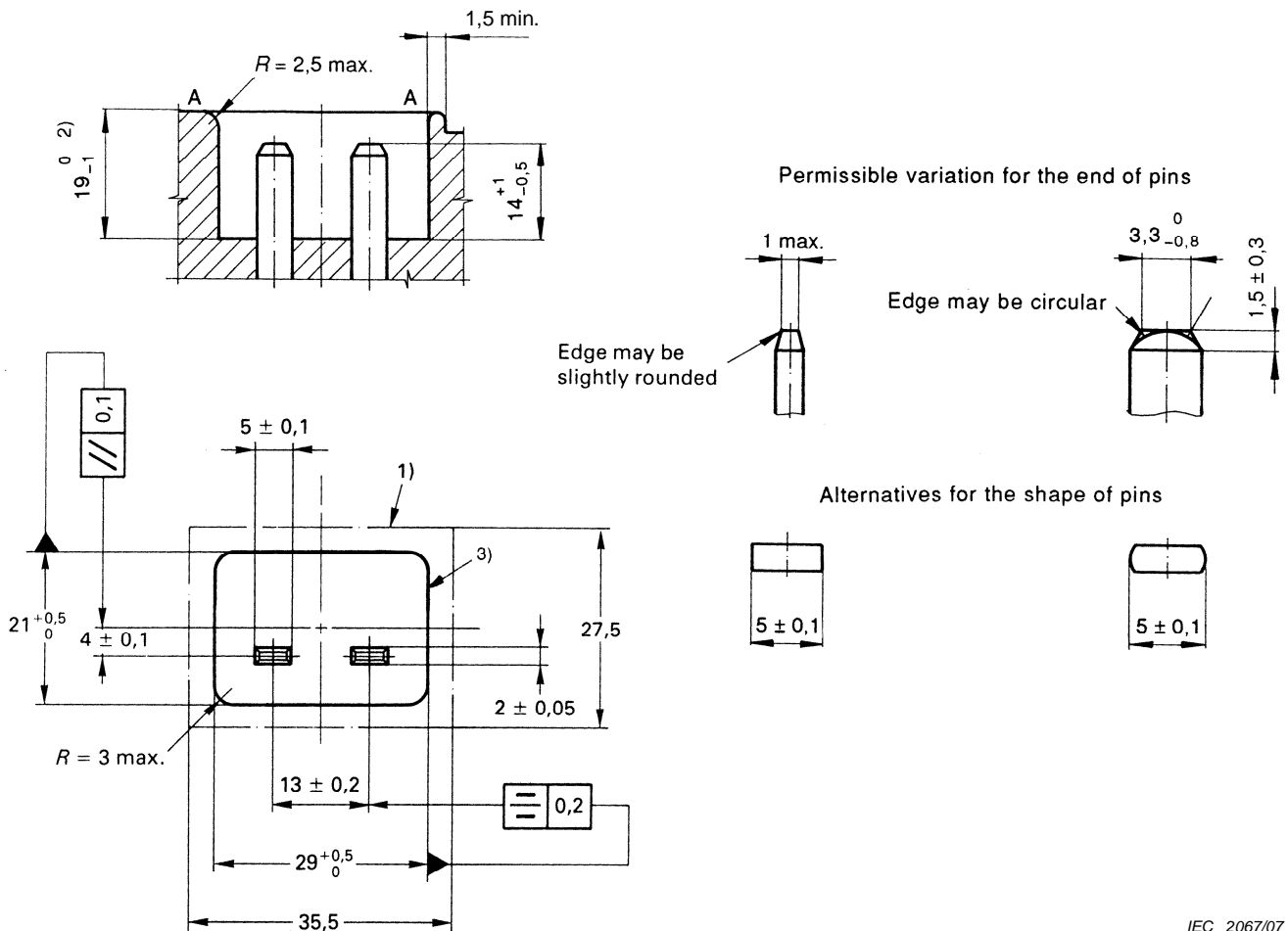

IEC 2067/07

*Dimensions in millimetres*

The outline 3) shall be at a distance of  $19 \begin{smallmatrix} 0 \\ -1 \end{smallmatrix}$  mm from the engagement face at the bottom of the inlet. The distance from the engagement face at the bottom of the inlet to plane A-A may, however, be less elsewhere within the area 1). Plane A-A need not necessarily be extended to the outline of area 1). A rim which is slightly rounded on top is allowed around the recess if it has a thickness of at least 1,5 mm. Retaining devices or parts thereof may be within the area 1). No other parts of the inlet may protrude beyond plane A-A.

2) For appliance inlets arranged countersunk in the outer surface of equipment and if this surface is curved or inclined with respect to the axis of the appliance inlet, this dimension shall be not more than 19 mm; the minimum shall be determined in accordance with 9.5.

*The sketches are not intended to govern design, except as regards the dimension shown.*

For the symbols indicating the tolerance of form or of position, see ISO 1101.

STANDARD SHEET C25  
PROVISION FOR RETAINING DEVICES

DESIGN A

DESIGN B

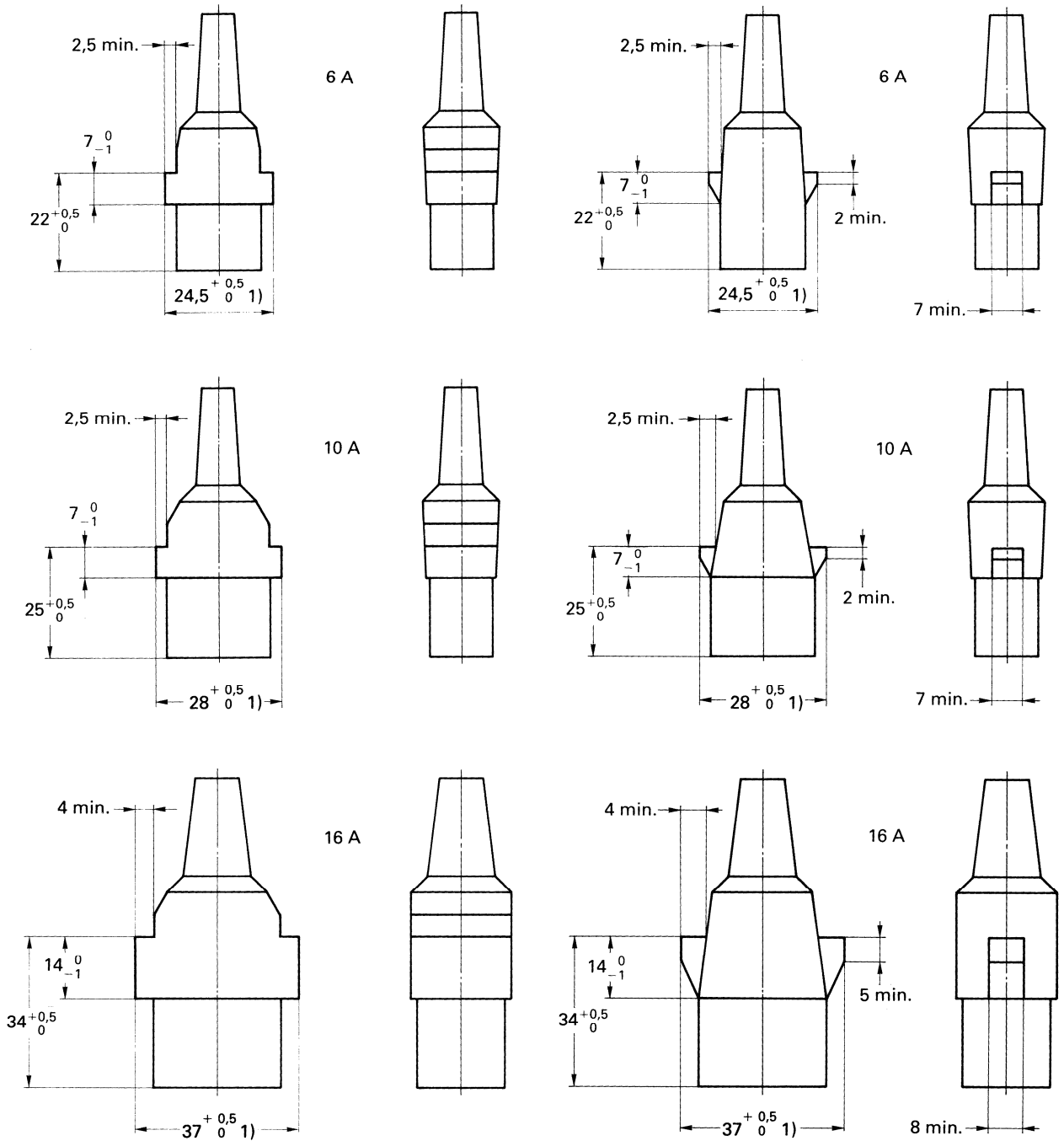

IEC 753/01

Dimensions in millimetres

1) This dimension shall not be exceeded within a distance from the engagement face of

- 28 mm for 6 A connectors
- 31 mm for 10 A connectors
- 40 mm for 16 A connectors

Above the retaining shoulders there shall be a free space of at least 5 mm in height.

The sketches are not intended to govern design, except as regards the dimensions shown.





Rated current of appliance coupler A	Class of equipment	Maximum temperature of appliance inlet	APPLIANCE COUPLER		Type of cord			Plug
			Number of standard sheet for: appliance inlet	connector	Rewirable construction allowed	Lightest type allowed	Minimum cross-section mm	Standard sheet of IEC 60083
0,2	II	70 °C	 C2	 C1	No	60227 IEC 41	- <sup>a</sup>	A 1-15 B C 5
2,5	I	70 °C	 C6	 C5	No	60227 IEC 52	0,75	A 5-15 B 2 C 2b C 4
2,5	II	70 °C	 C8	 C7	No	60227 IEC 52	0,75 <sup>b</sup>	A 1-15 B 2 C 5 C 6
6	II	70 °C	 C10	 C9	No	60227 IEC 52	0,75	A 1-15 B 2 C 6
10	I	70 °C	 C14	 C13	Yes	60227 IEC 53 or 60245 IEC 53	0,75 <sup>c</sup>	A 5-15 B 2 C 2b C 3b C 4
10	I	120 °C	 C16	 C15	Yes	60245 IEC 53 or 60245 IEC 51	0,75 <sup>c</sup>	A 5-15 B 2 C 2b C 3b C4

Figure 1 – Survey of appliance couplers

Rated current of appliance coupler A	Class of equipment	Maximum temperature of appliance inlet	APPLIANCE COUPLER		Type of cord			Plug
			Number of standard sheet for:		Rewirable construction allowed	Lightest type allowed	Minimum cross-section mm	Standard sheet of IEC 60083
		appliance inlet	connector					
10	I	155 °C			Yes	60245 IEC 53 or 60245 IEC 51	0,75 <sup>c</sup>	A 5-15 B 2 C 2b C 3b C 4
10	II	70 °C			No	60227 IEC 53 or 60245 IEC 53	0,75 <sup>c</sup>	A 1-15 B 2 C 6
16	I	70 °C			Yes	60227 IEC 53 or 60245 IEC 53	1 <sup>c</sup>	A 5-15 B 2 C 2b C 3b C 4
16	I	155 °C			Yes	60245 IEC 53 or 60245 IEC 51	1 <sup>c</sup>	A 5-15 B 2 C 2b C 3b C 4
16	II	70 °C			No	60227 IEC 53 or 60245 IEC 53	1 <sup>c</sup>	A 1-15 B 2 C 6

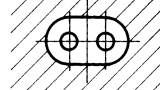
a Only for small hand-held appliances, in length not exceeding 2 m, if allowed by the relevant appliance standard.  
 b 0,5 mm<sup>2</sup> is allowed for lengths not exceeding 2 m.  
 c If the cord has a length exceeding 2 m or is of the retractable coiled (pre-coiled) type, nominal cross-sectional areas shall be  
 - 1 mm<sup>2</sup> for 10 A connectors  
 - 1,5 mm<sup>2</sup> for 16 A connectors.

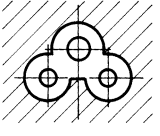
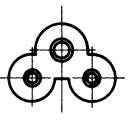
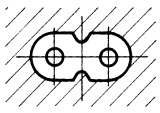
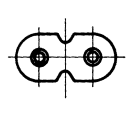
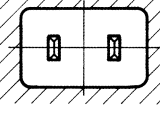
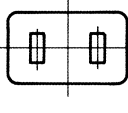
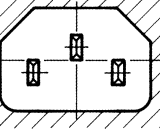
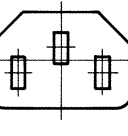
Figure 1 – Survey of appliance couplers (concluded)

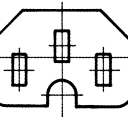
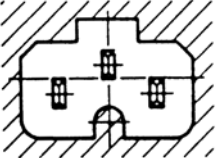
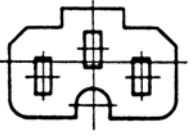
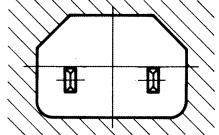
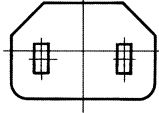
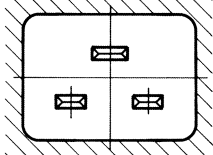
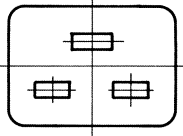
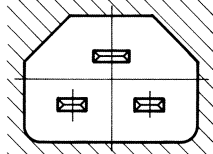
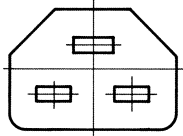
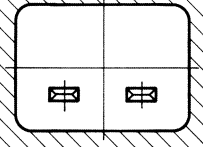
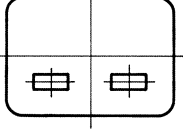

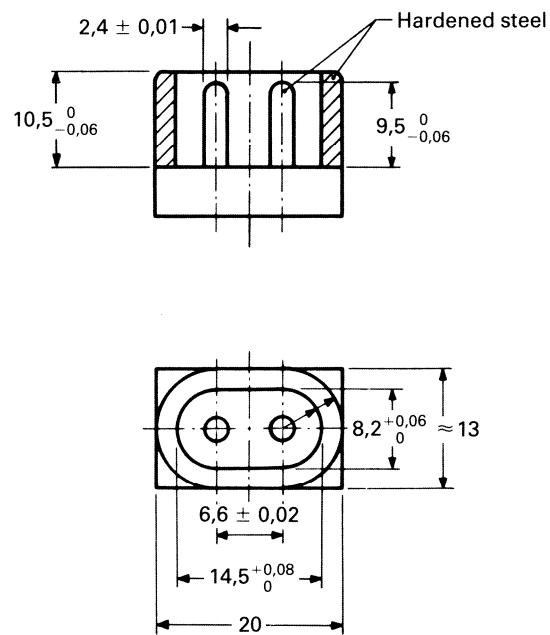

IEC 758/01

*Dimensions in millimetres*

It shall be possible to insert the connector fully into the gauge with a force not exceeding 60 N.

For the purpose of verifying whether or not the connector is fully inserted, it is recommended that the gauge be provided with an aperture.

**Figure 2 – "GO" gauge for connectors to standard sheet C1 (see 9.1)**

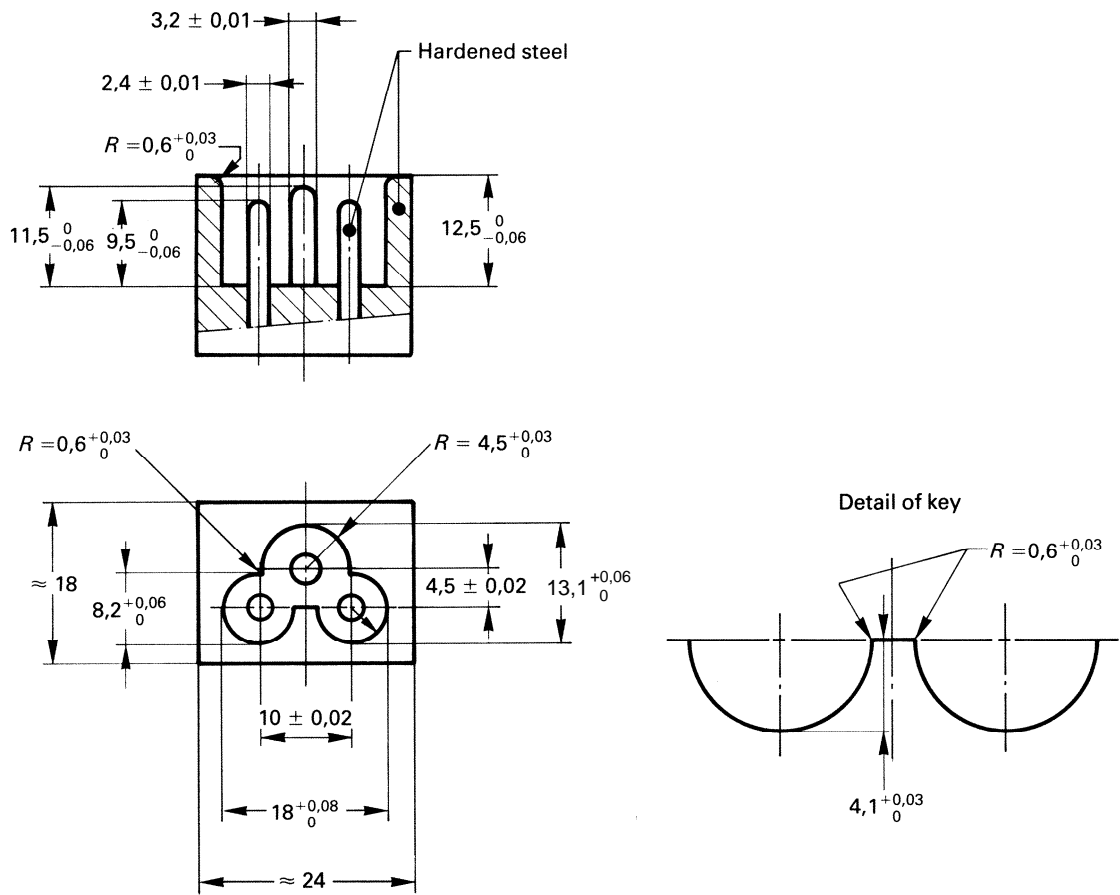

IEC 1667/07

Figure 4 – “GO” gauge for connectors to standard sheet C5 (see 9.1)

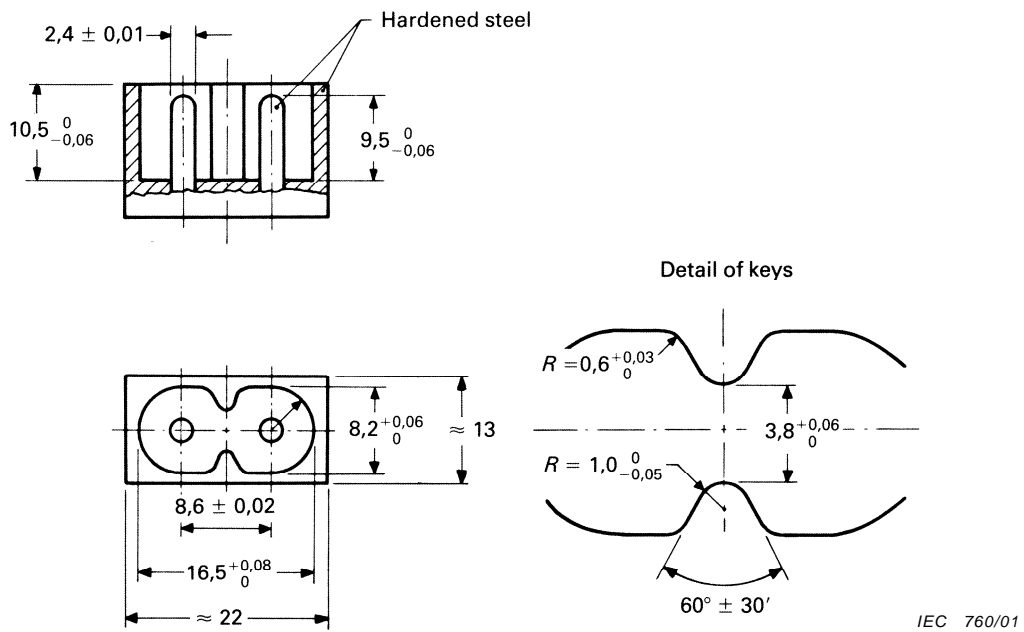

*Dimensions in millimetres*

It shall be possible to insert the connector fully into the gauge with a force not exceeding 60 N.

For the purpose of verifying whether or not the connector is fully inserted, it is recommended that the gauge be provided with an aperture.

**Figure 5 – "GO" gauge for connectors to standard sheet C7 (see 9.1)**

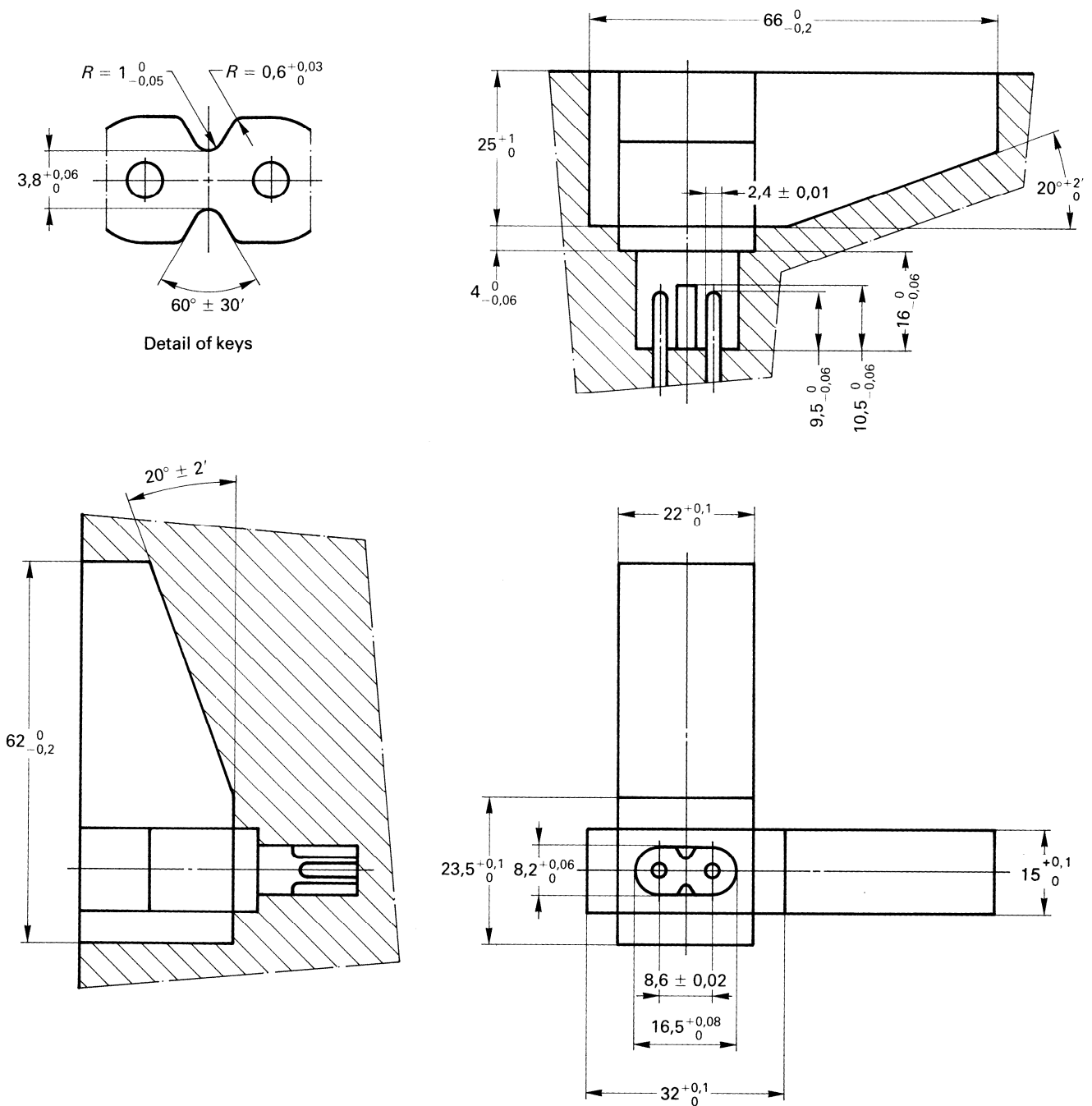

IEC 761/01

Dimensions in millimetres

It shall be possible to insert the connector fully into the gauge with a force not exceeding 60 N.

For the purpose of verifying whether or not the connector is fully inserted, it is recommended that the gauge be provided with an aperture.

Figure 5A – "GO" gauge for side-entry connectors to standard sheet C7 (see 9.1)

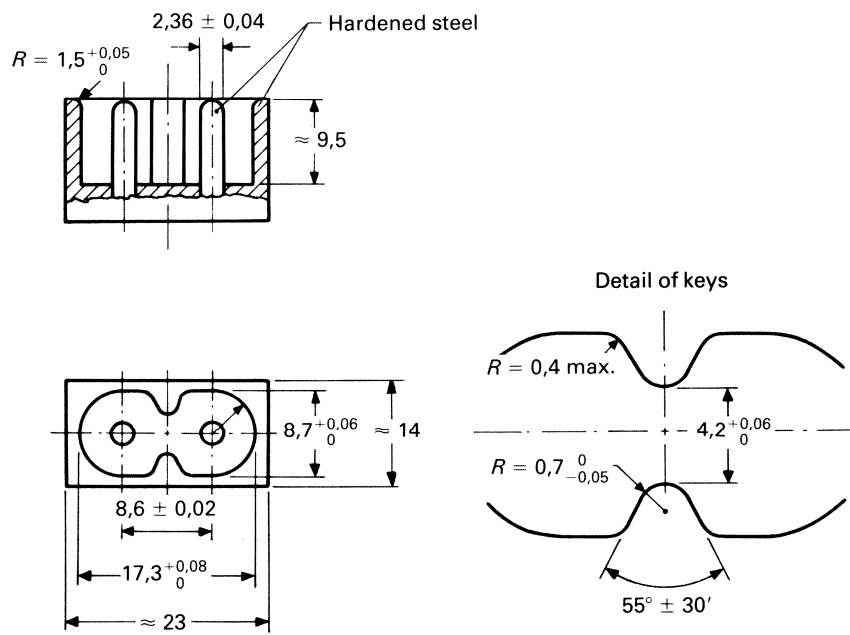

IEC 762/01

Dimensions in millimetres

It shall not be possible to insert the connector into the gauge with a force of 60 N.

**Figure 6 – "NOT GO" gauge for connectors to standard sheet C1 (see 9.4)**

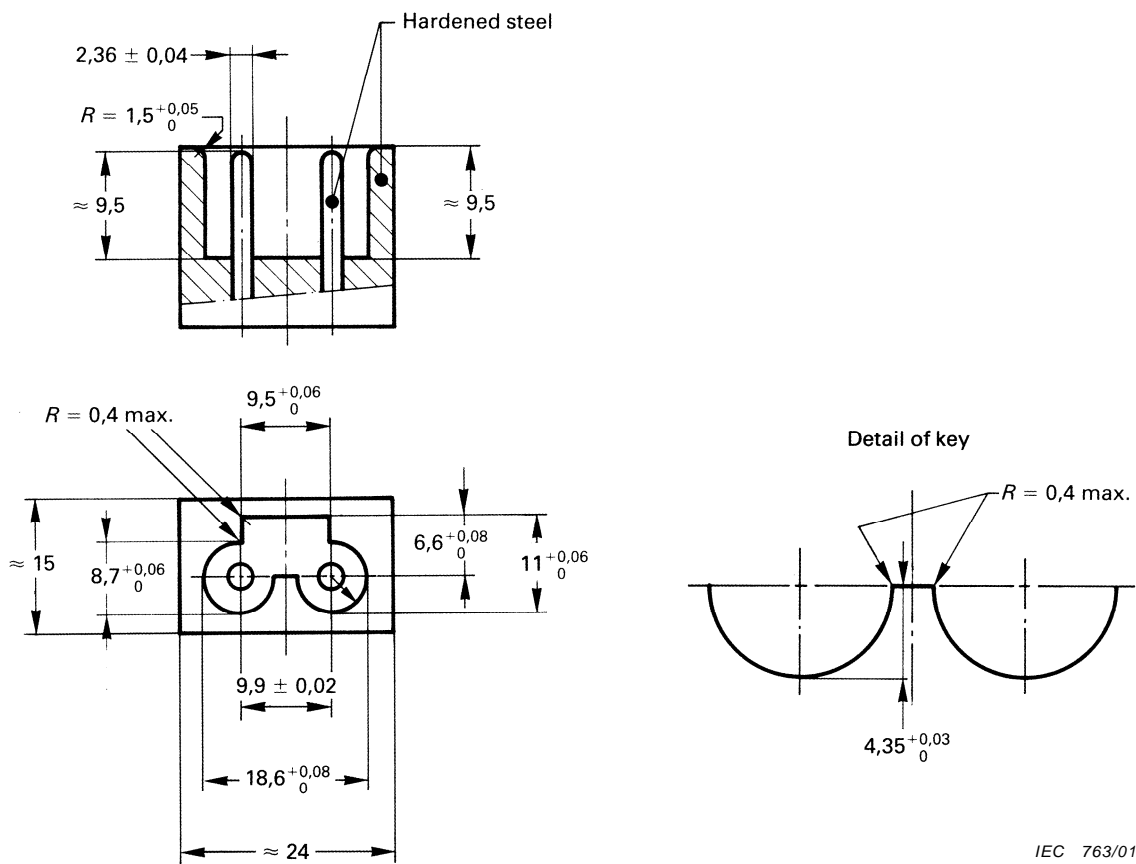

Dimensions in millimetres

It shall not be possible to insert the connector into the gauge with a force of 60 N.

Figure 7 – "NOT-GO" gauge for connectors to standard sheets C1, C5 and C7 (see 9.4)

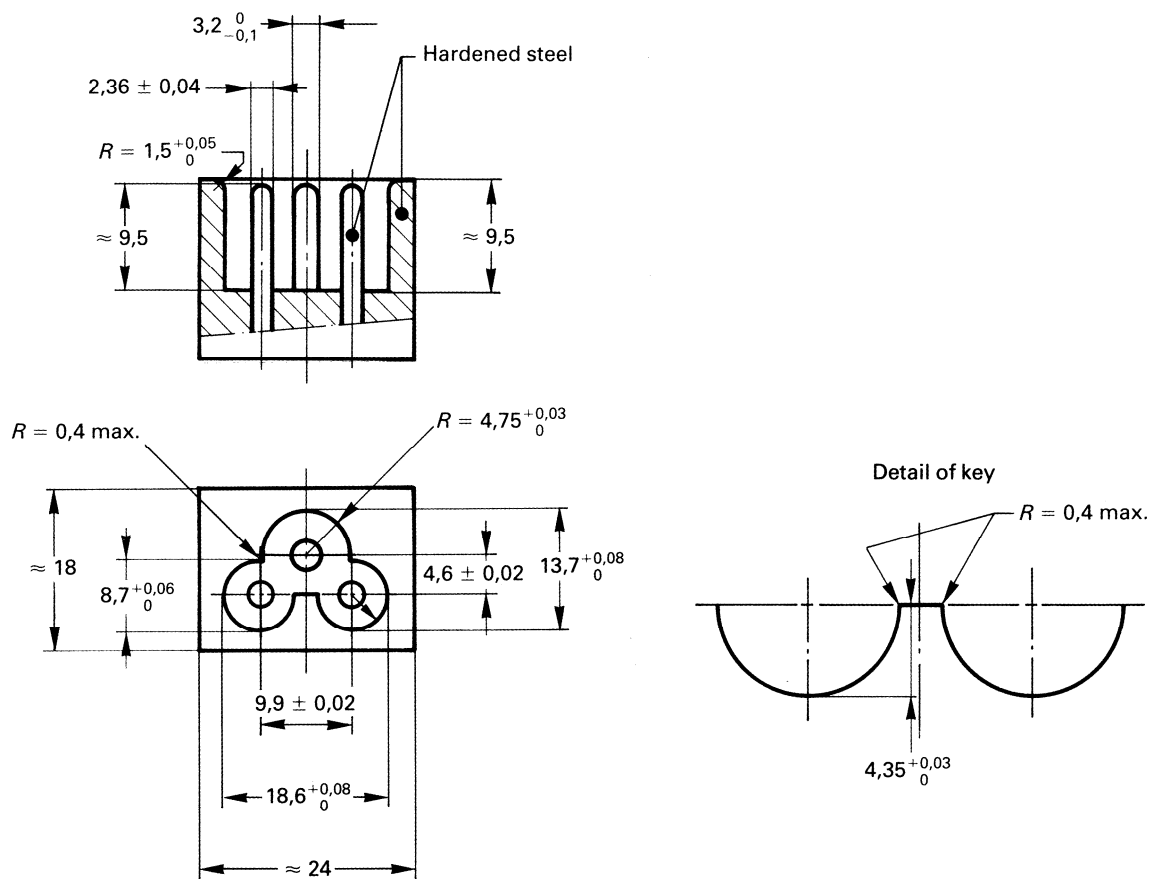

IEC 764/01

Dimensions in millimetres

It shall not be possible to insert the connector into the gauge with a force of 60 N.

**Figure 8 – "NOT-GO" gauge for connectors to standard sheets C1 and C7 (see 9.4)**

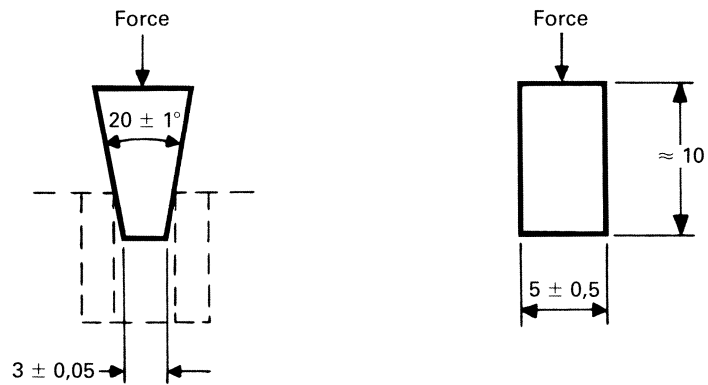

IEC 765/01

*Dimensions in millimetres*

When the gauge is inserted between the ridges of the appliance inlet with a force of 30 N, it shall not touch the bottom of the inlet.

**Figure 9 – "NOT-GO" gauge for appliance inlets to standard sheets C8, C8A and C8B (see 9.4)**



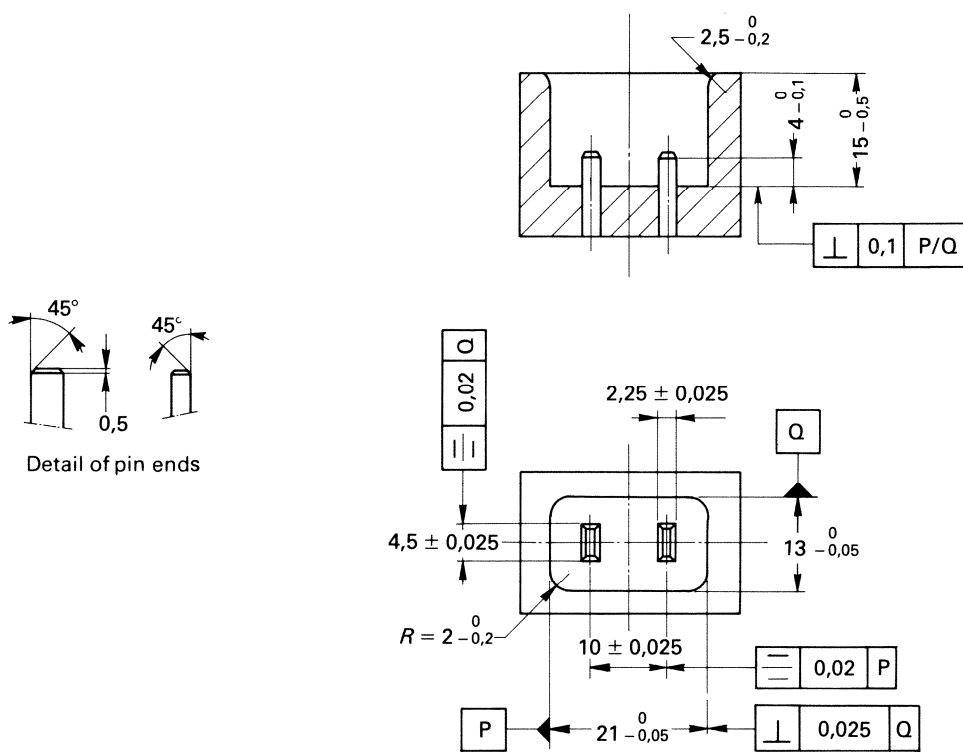

IEC 766/01

Dimensions in millimetres

Gauge and pins: hardened steel.

It shall be possible to insert the connector fully into the gauge with a force not exceeding 60 N.

For the purpose of verifying whether or not the connector is fully inserted, it is recommended to provide the gauge with an aperture.

For the symbols indicating the tolerance of form or of position, see ISO 1101.

Figure 9A – "GO" gauge for connectors to standard sheet C9 (see 9.1)

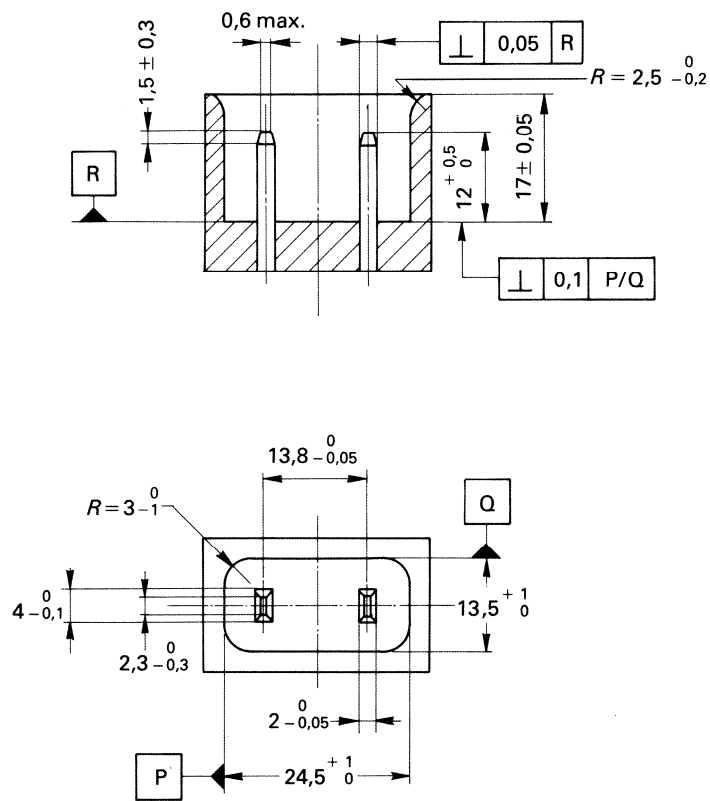

IEC 767/01

*Dimensions in millimetres*

Gauge and pins: hardened steel.

It shall not be possible to insert the connector into the gauge with a force not exceeding 60 N.

For the symbols indicating the tolerance of form or of position, see ISO 1101.

**Figure 9B – "NOT-GO" gauge for connectors to standard sheet C9 (see 9.4)**



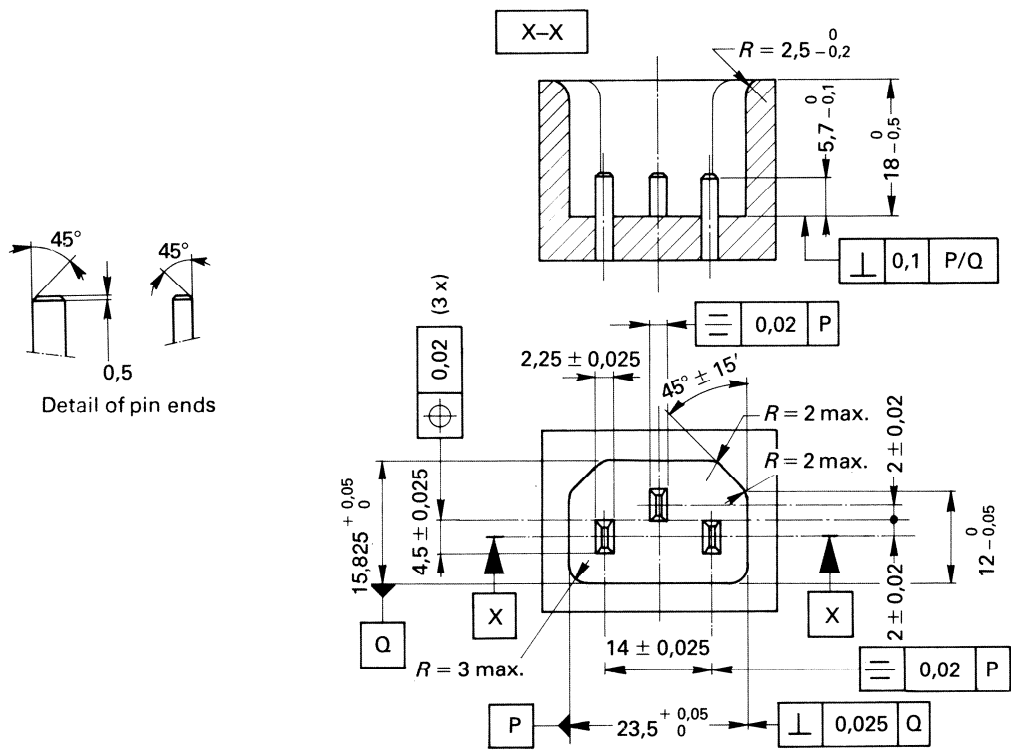

IEC 769/01

Dimensions in millimetres

Gauge and pins: hardened steel.

It shall be possible to insert the connector fully into the gauge with a force not exceeding 60 N.

For the purpose of verifying whether or not the connector is fully inserted, it is recommended to provide the gauge with an aperture.

For the symbols indicating the tolerance of form or of position, see ISO 1101.

Figure 9F – "GO" gauge for connectors to standard sheet C13 (see 9.1)

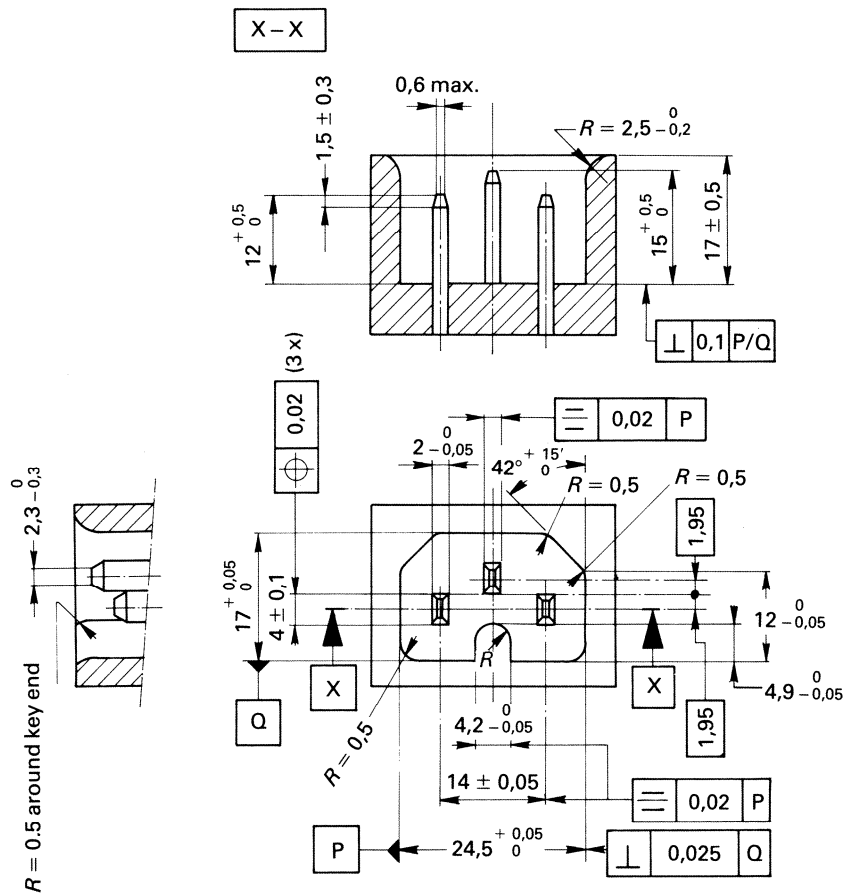

IEC 770/01

Dimensions in millimetres

Gauge and pins: hardened steel.

It shall not be possible to insert the connector into the gauge with a force not exceeding 60 N.

For the symbols indicating the tolerance of form or of position, see ISO 1101.

Figure 9G – "NOT-GO" gauge for connectors to standard sheets C13 and C17 (see 9.4)

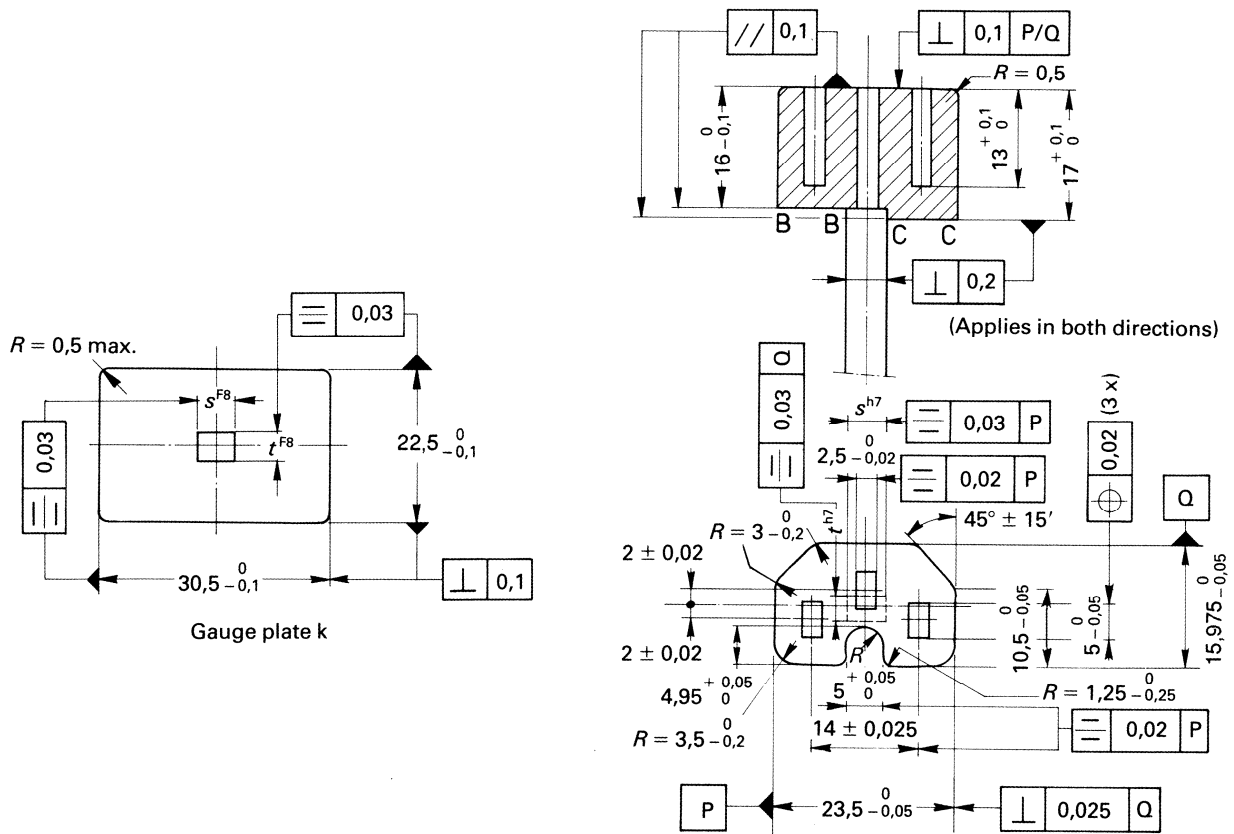

IEC 771/01

Dimensions in millimetres

Gauge: hardened steel.

The thickness of the gauge plate K, as well as the nominal values of the dimensions *s* and *t* of the handle and of the hole in the gauge plate, are left free, but the tolerances h7 and F8 shall be respected.

It shall be possible to insert the gauge fully into the appliance inlet with a force not exceeding 60 N. The plane A-A of the inlet shall lie between planes B-B and C-C of the gauge.

Then the gauge plate K shall be pushed over the handle to check the free area around the inlet opening.

For the symbols indicating the tolerance of form or of position, see ISO 1101; for the symbols for tolerances on dimensions, see ISO 286-1.

**Figure 9H – "GO" gauge for appliance inlets to standard sheets C14, C16 and C18 (see 9.1)**



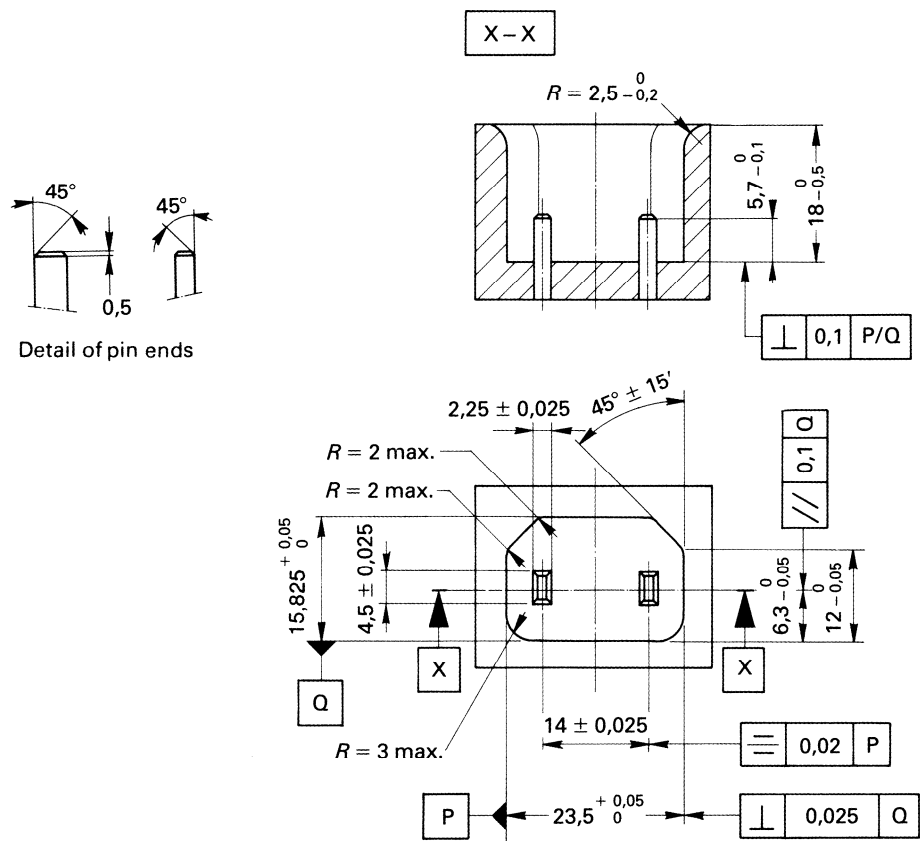

IEC 773/01

Dimensions in millimetres

Gauge and pins: hardened steel.

It shall be possible to insert the connector fully into the gauge with a force not exceeding 60 N.

For the purpose of verifying whether or not the connector is fully inserted, it is recommended that the gauge be provided with an aperture.

For the symbols indicating the tolerance of form or of position, see ISO 1101.

Figure 9K – "GO" gauge for connectors to standard sheet C17 (see 9.1)



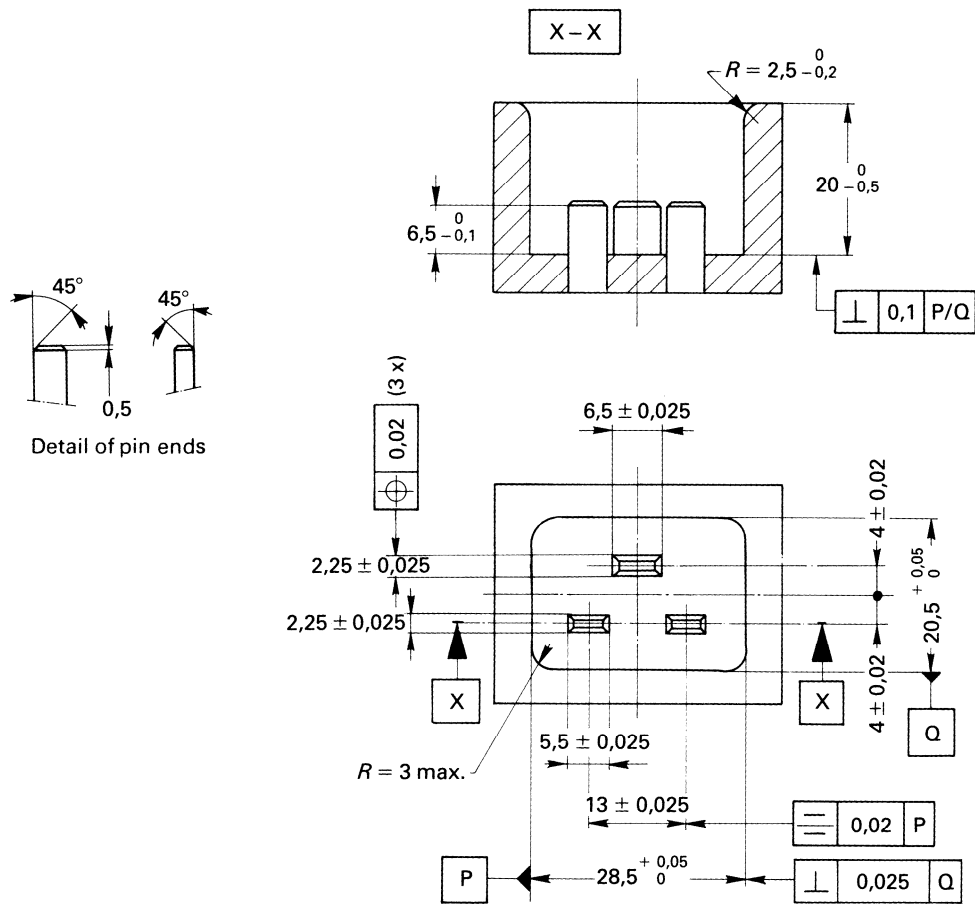

IEC 774/01  
Dimensions in millimetres

Gauge and pins: hardened steel.

It shall be possible to insert the connector fully into the gauge with a force not exceeding 60 N.

For the purpose of verifying whether or not the connector is fully inserted, it is recommended to provide the gauge with an aperture.

For the symbols indicating the tolerance of form or of position, see ISO 1101.

Figure 9L - "GO" gauge for connectors to standard sheet C19 (see 9.1)

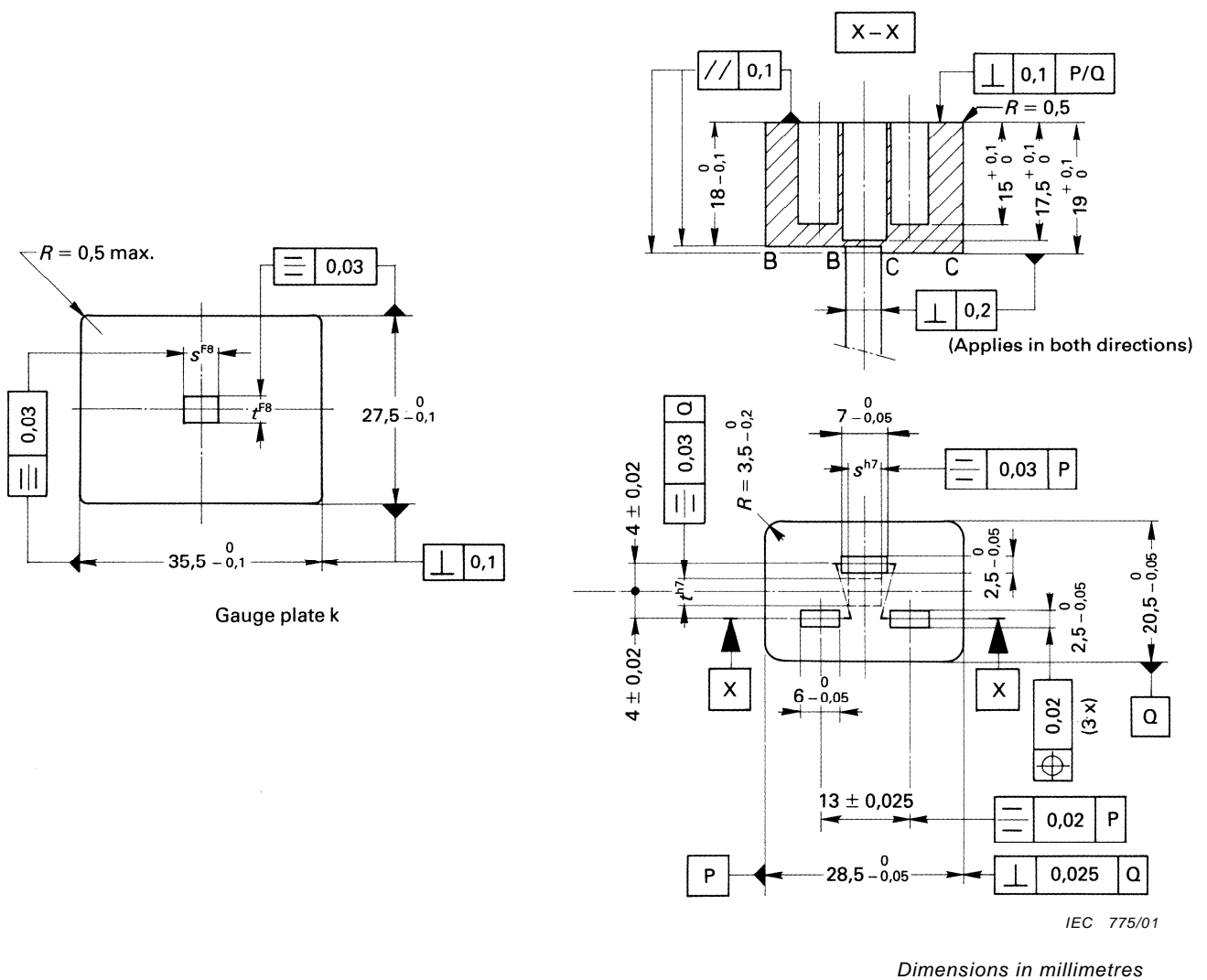

Gauge: hardened steel.

The thickness of the gauge plate K, as well as the nominal values of the dimensions *s* and *t* of the handle and of the hole in the gauge plate, are left free, but the tolerances h7 and F8 shall be respected.

It shall be possible to insert the gauge fully into the appliance inlet with a force not exceeding 60 N. The plane A-A of the inlet shall lie between planes B-B and C-C of the gauge.

Then the gauge plate K shall be pushed over the handle to check the free area around the inlet opening.

For the symbols indicating the tolerance of form or of position, see ISO 1101; for the symbols for tolerances on dimensions, see ISO 286-1.

**Figure 9M – "GO" gauge for appliance inlets to standard sheets C20 and C24 (see 9.1)**



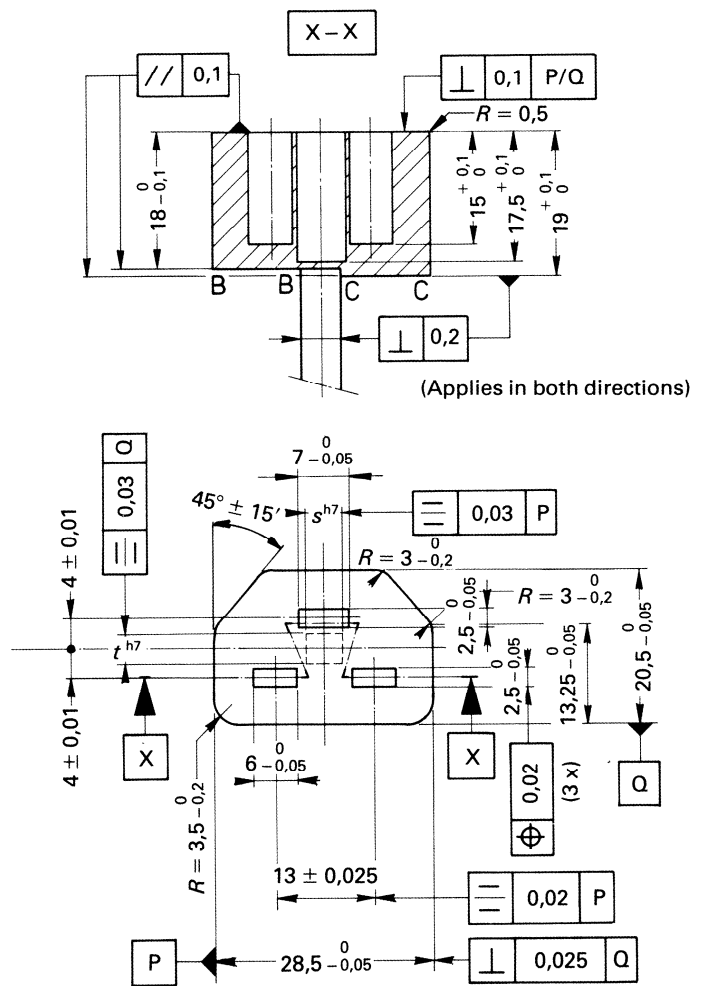
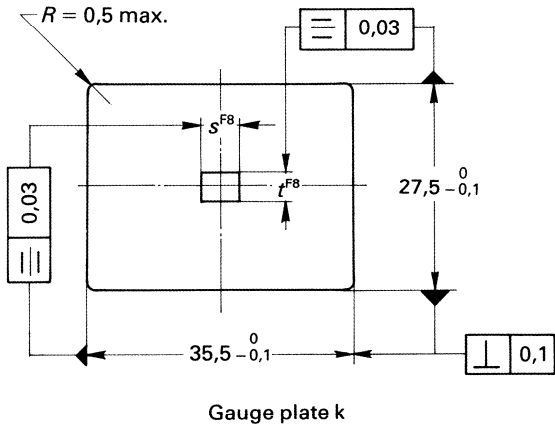

IEC 777/01

Dimensions in millimetres

Gauge: hardened steel.

The thickness of the gauge plate K, as well as the nominal values of the dimensions *s* and *t* of the handle and of the hole in the gauge plate, are left free, but the tolerances h7 and F8 shall be respected.

It shall be possible to insert the gauge fully into the appliance inlet with a force not exceeding 60 N. The plane A-A of the inlet shall lie between planes B-B and C-C of the gauge.

Then the gauge plate K shall be pushed over the handle to check the free area around the inlet opening.

For the symbols indicating the tolerance of form or of position, see ISO 1101; for the symbols for tolerances on dimensions, see ISO 286-1.

Figure 9P – "GO" gauge for appliance inlets to standard sheet C22 (see 9.1)

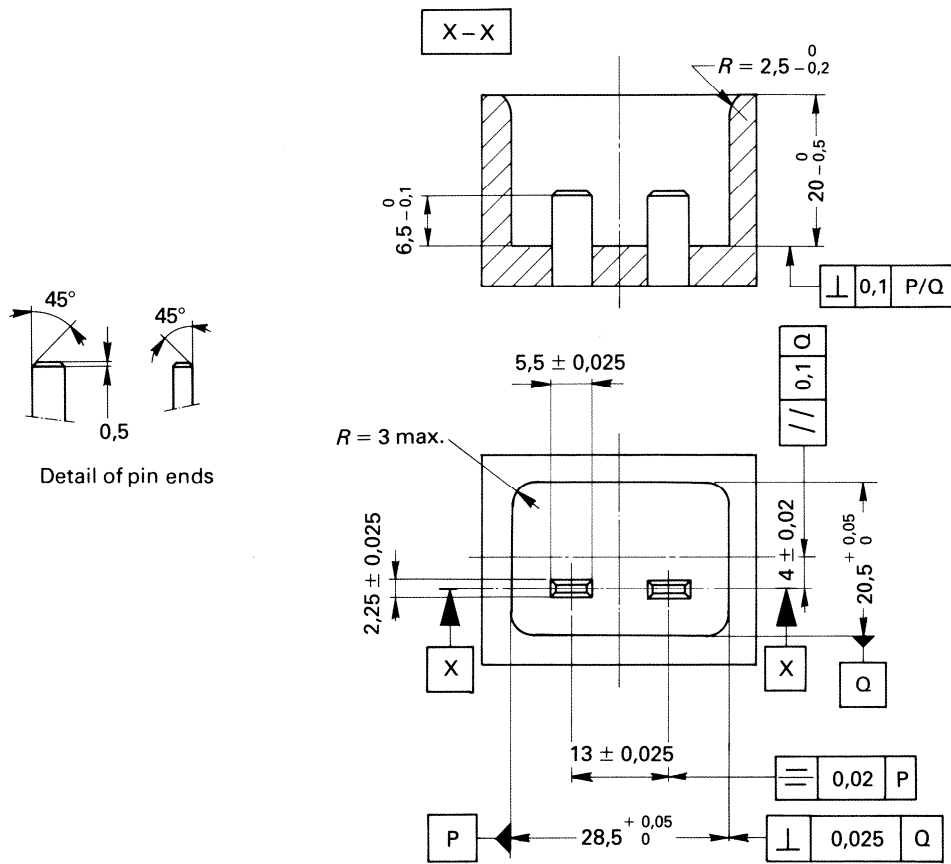

IEC 778/01

Dimensions in millimetres

Gauge and pins: hardened steel.

It shall be possible to insert the connector fully into the gauge with a force not exceeding 60 N.

For the purpose of verifying whether or not the connector is fully inserted, it is recommended to provide the gauge with an aperture.

For the symbols indicating the tolerance of form or of position, see ISO 1101.

Figure 9Q – "GO" gauge for connectors to standard sheet C23 (see 9.1)

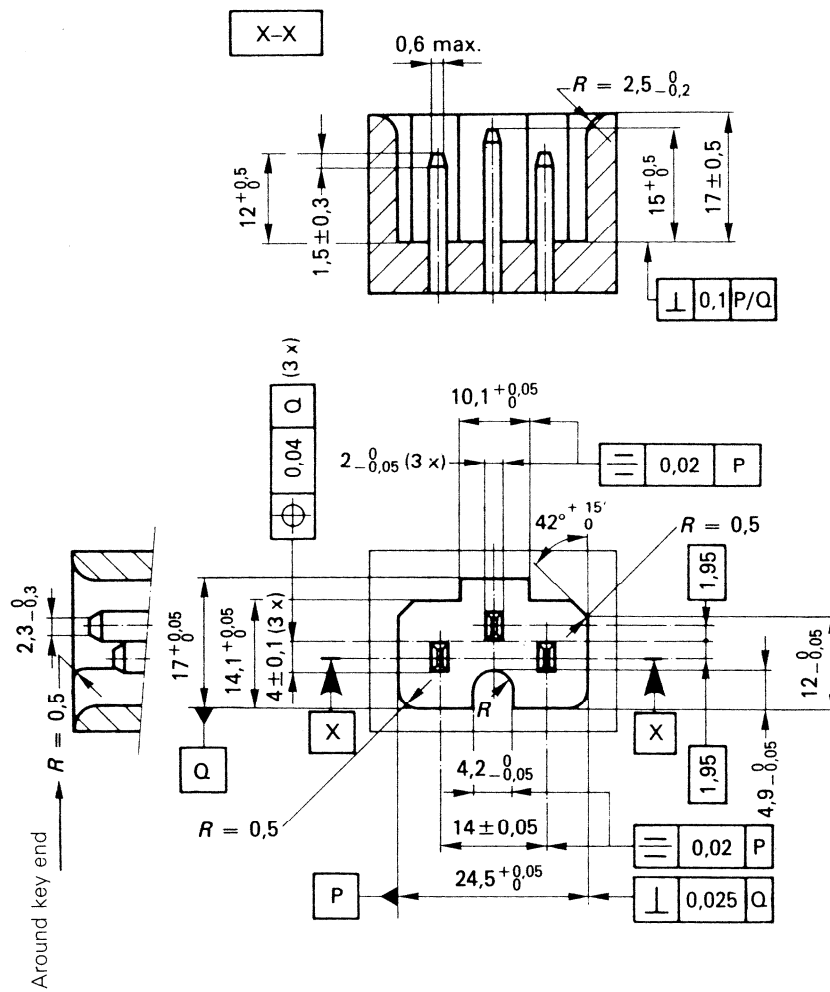

IEC 779/01

Dimensions in millimetres

Gauge and pins: hardened steel.

It shall not be possible to insert the connector into the gauge with a force not exceeding 60 N.

For the symbols indicating the tolerance of form or of position, see ISO 1101.

Figure 9R – "NOT-GO" gauge for connectors to standard sheets C13, C15 and C17 (see 9.4)

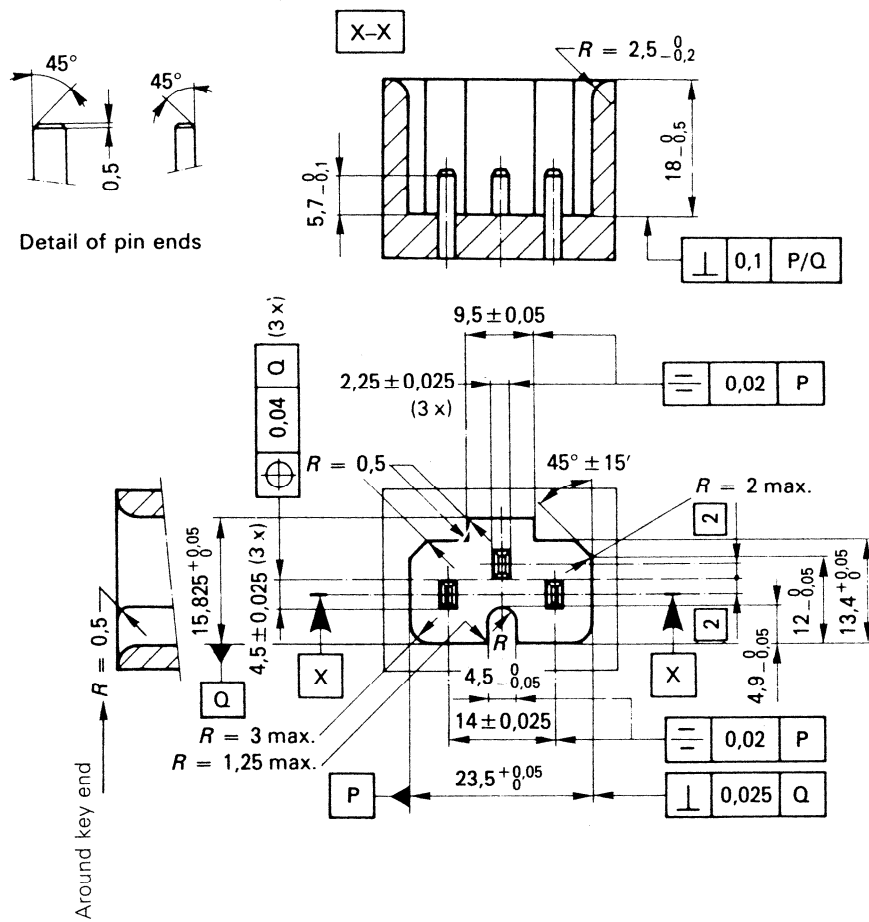

IEC 780/01

Dimensions in millimetres

Gauge and pins: hardened steel.

It shall be possible to insert the connector fully into the gauge with a force not exceeding 60 N.

For the purpose of verifying whether or not the connector is fully inserted, it is recommended to provide the gauge with an aperture.

For the symbols indicating the tolerance of form or of position, see ISO 1101.

Figure 9S – "GO" gauge for connectors to standard sheet C15A (see 9.1)

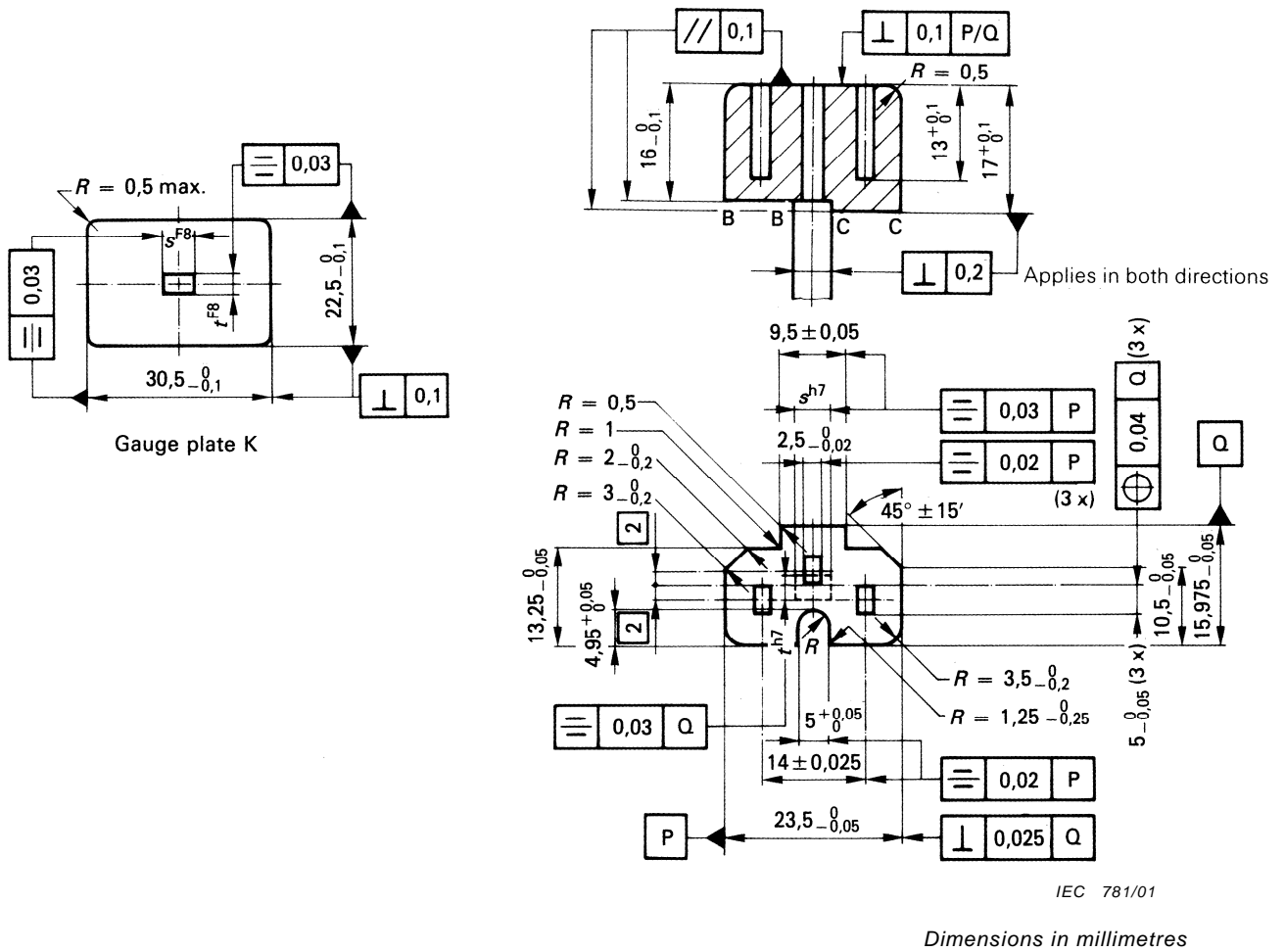

Gauge: hardened steel.

The thickness of the gauge plate K, as well as the nominal values of the dimensions  $s$  and  $t$  of the handle and of the hole in the gauge plate, are left free, but the tolerances  $h7$  and  $F8$  shall be respected.

It shall be possible to insert the gauge fully into the appliance inlet with a force not exceeding 60 N. The plane A-A of the inlet shall lie between planes B-B and C-C of the gauge.

Then the gauge plate K shall be pushed over the handle to check the free area around the inlet opening.

For the symbols indicating the tolerance of form or of position, see ISO 1101; for the symbols for tolerances on dimensions, see ISO 286-1.

Figure 9T – "GO" gauge for appliance inlets to standard sheet C16A (see 9.1)





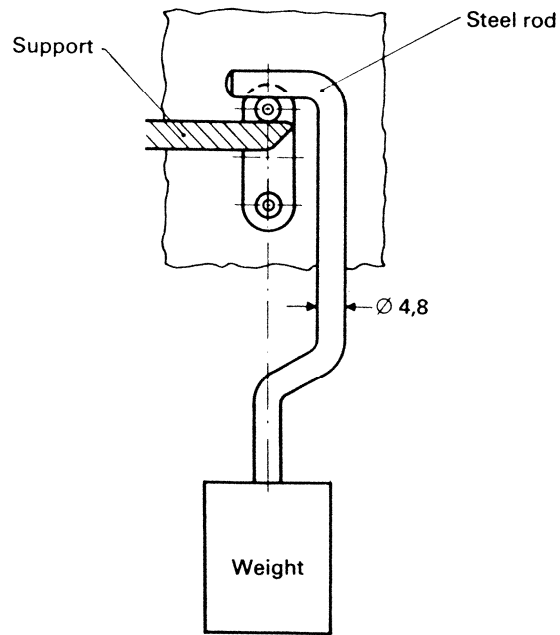

IEC 783/01

Dimensions in millimetres

Figure 11 – Device for testing non-solid pins (see 13.4)

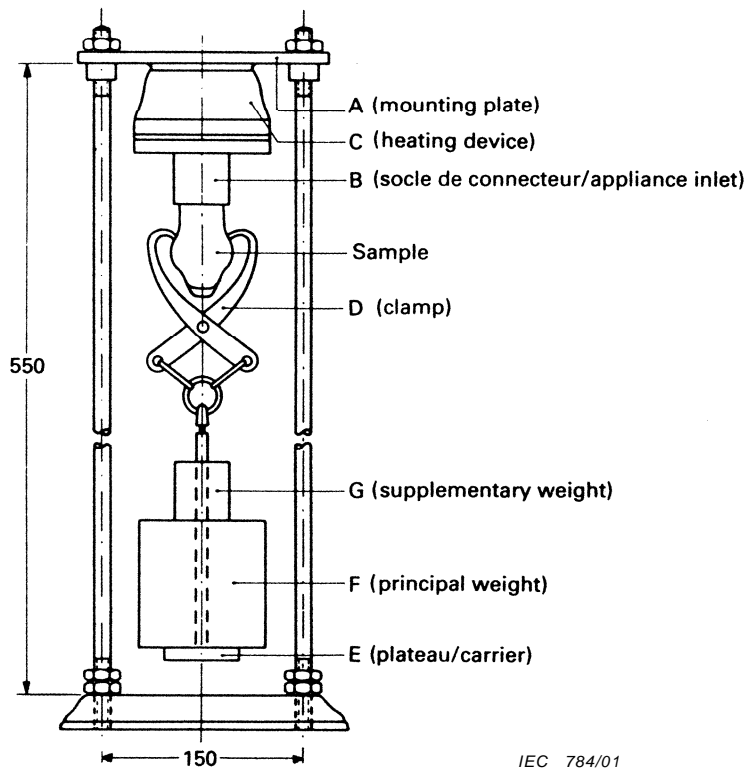

IEC 784/01

Figure 12 – Apparatus for checking the withdrawal force (see 16.2)

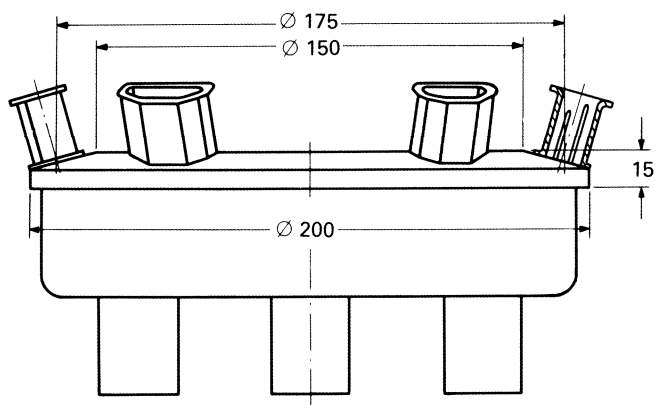

IEC 785/01

*Dimensions in millimetres  
Dimensions are approximate*

**Figure 13 – Example of apparatus for heating test (see 18.2)**

**Figure 14 – VOID**

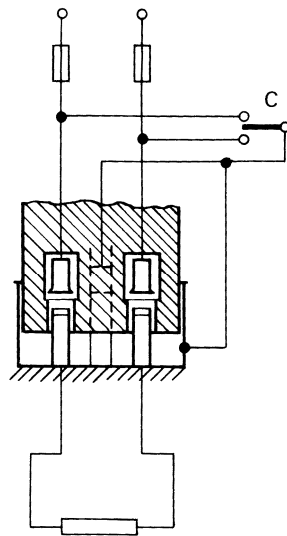

IEC 786/01

Figure 15 – Circuit diagram for breaking capacity and normal operation tests (see clauses 19 and 20)

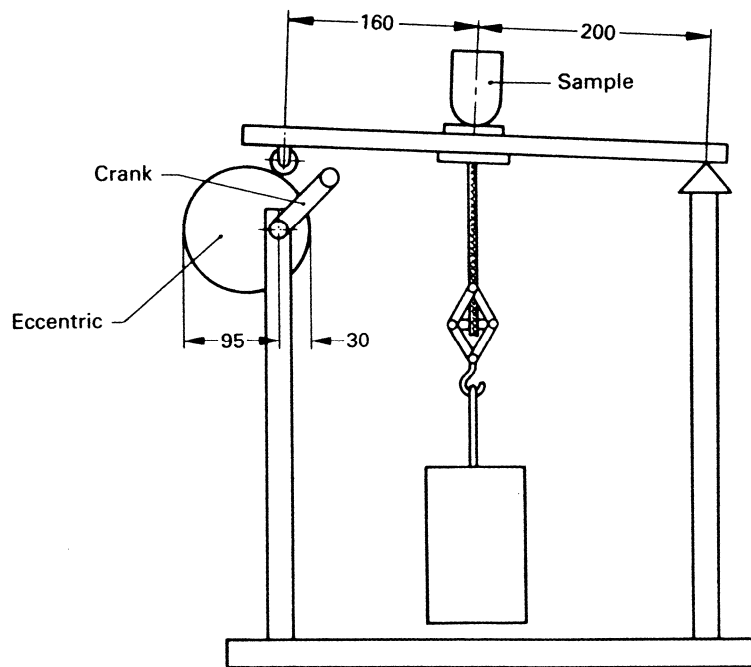

IEC 787/01

Dimensions in millimetres

Figure 16 – Apparatus for testing the cord anchorage (see 22.3)

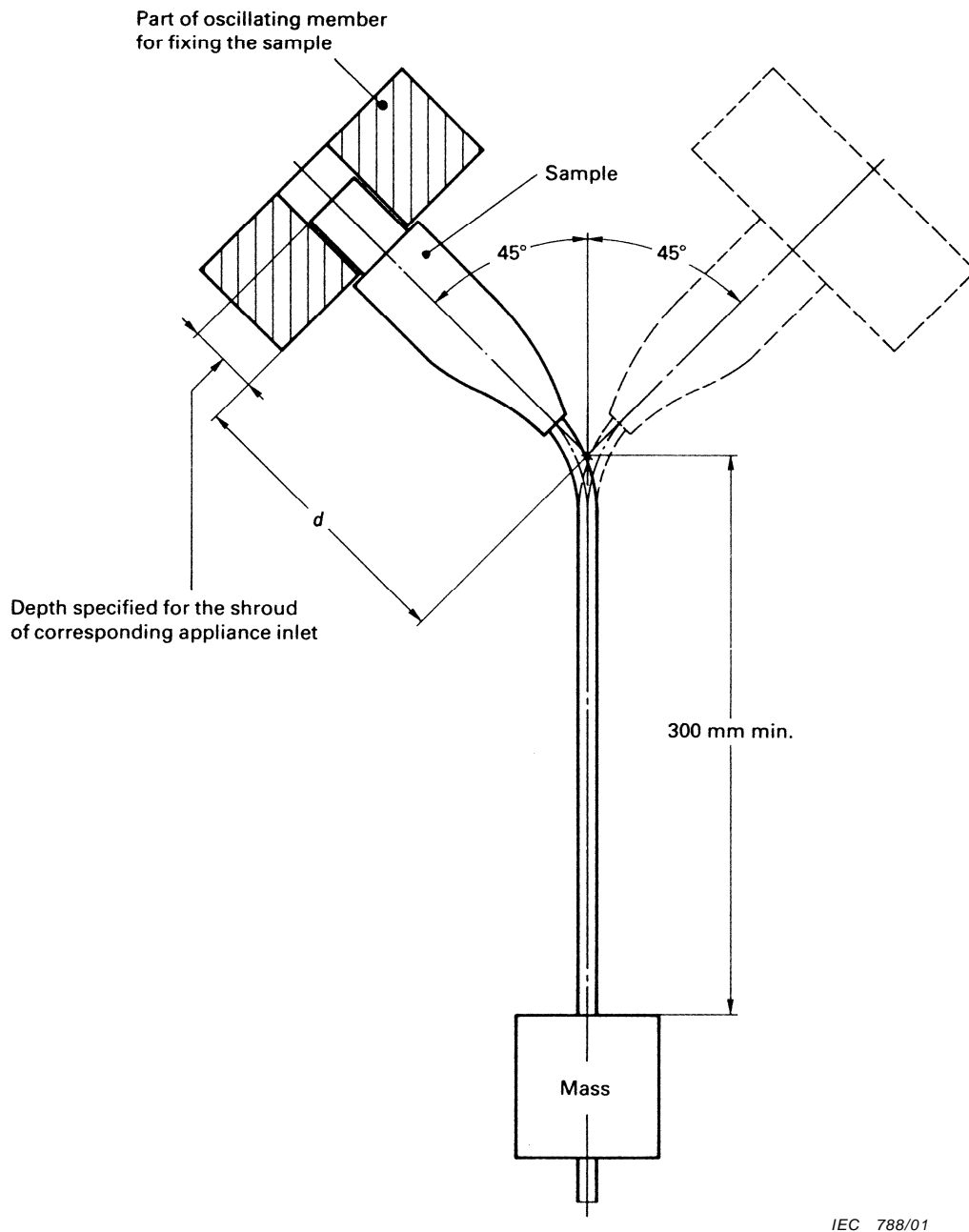
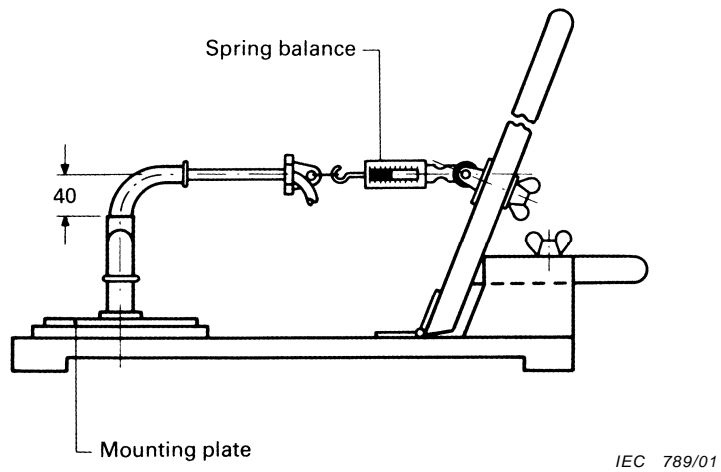

Figure 17 – Apparatus for the flexing test (see 22.4)

Figure 18 – VOID



*Dimensions in millimetres*

**Figure 19 – Example of apparatus for pulling test (see 23.3)**

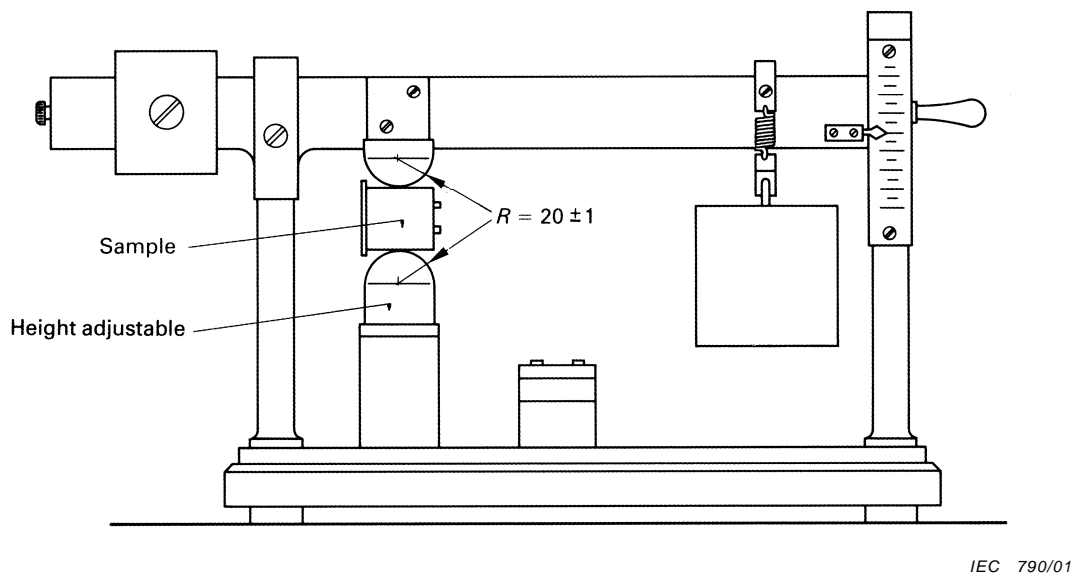

*Dimensions in millimetres*

**Figure 20 – Example of apparatus for pressure test on shrouds (see 23.4)**

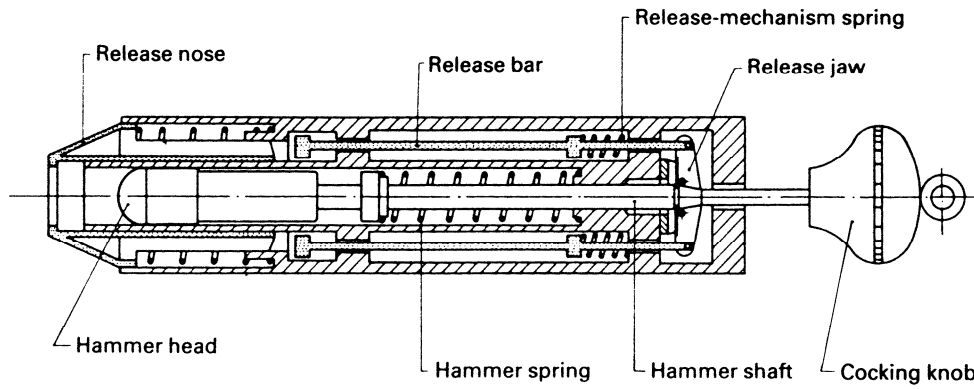

IEC 791/01

Figure 21 – Impact-test apparatus (see 23.5)

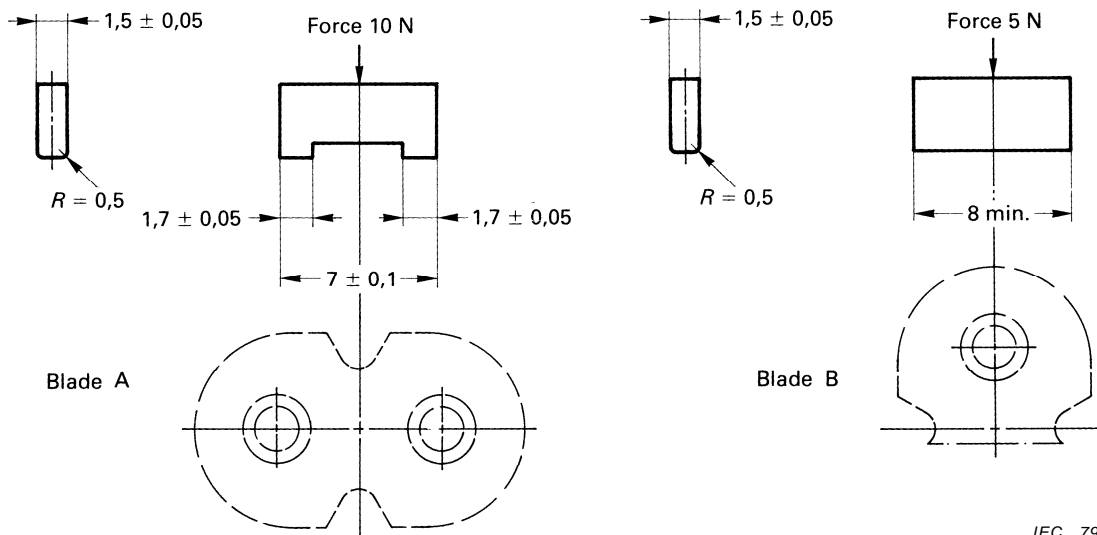

IEC 792/01

Dimensions in millimetres

Figure 22 – Blades for checking the resistance against deformation of the front part of the connector to standard sheet C7 (see 23.6)

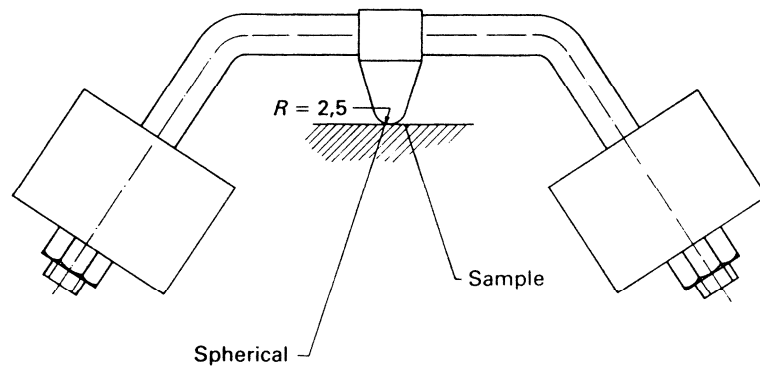

IEC 793/01

*Dimensions in millimetres*

**Figure 23 – Ball-pressure apparatus (see 24.1.2)**



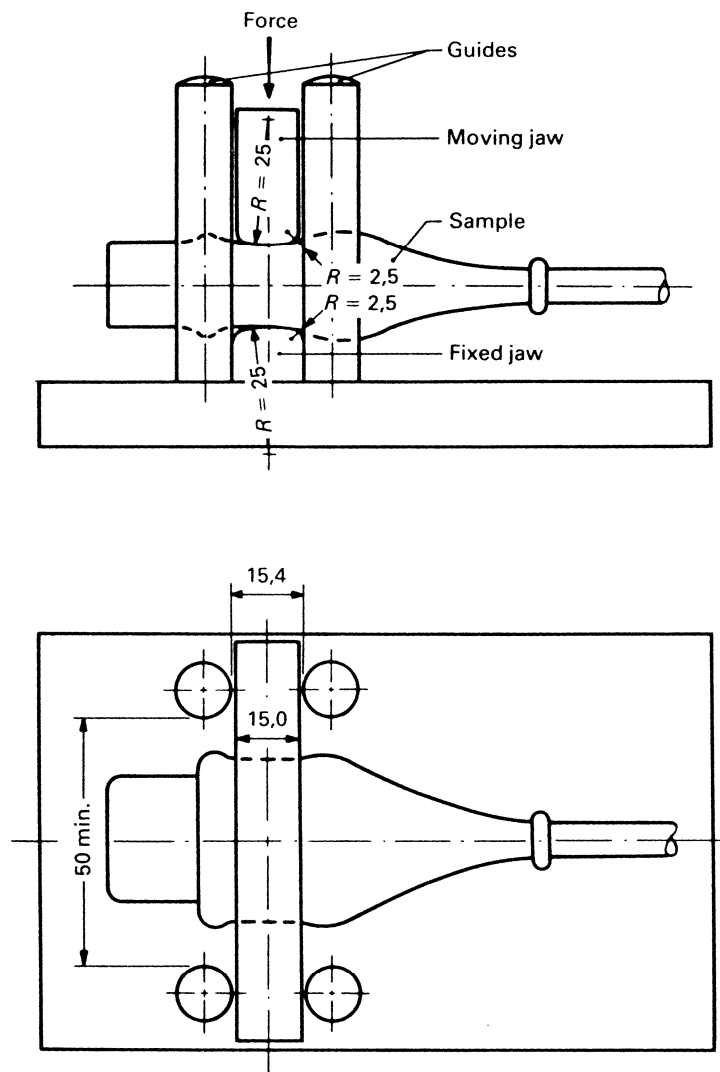

IEC 794/01

Dimensions in millimetres

Figure 24 – Apparatus for pressure test on connectors (see 24.1.3)

Figure 25 – VOID

Figure 26 – VOID

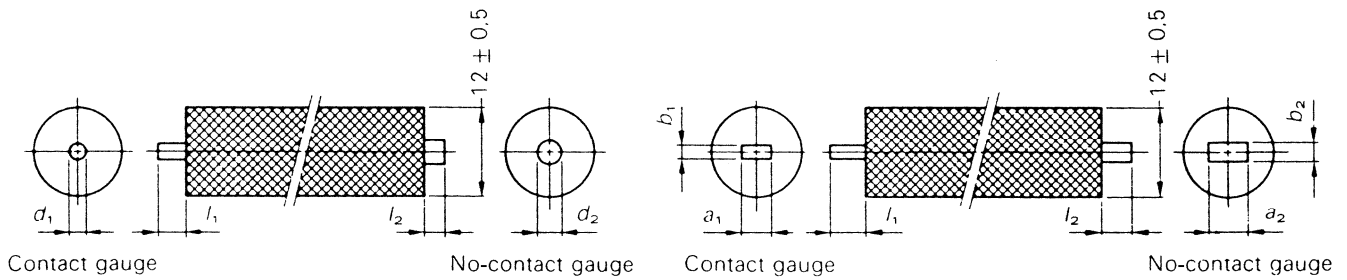

IEC 795/01

Dimensions in millimetres

Gauge for 0,2 A and 2,5 A connectors

Gauge for 6 A, 10 A and 16 A connectors

Dimension	Tolerance	Rated current of connector			
		0,2 A 2,5 A	6 A	10 A	16 A
$a_1$	+0,05 0	–	3,9	3,9	4,9 5,2 <sup>2)</sup>
$b_1$	+0,05 0	–	1,95	1,95	1,95
$d_1$	+0,02 0	2,32 3,10 <sup>1)</sup>	–	–	–
$l_1$	+0,05 0	3,8	5,5	7,2	8,0
$a_2$	0 –0,05	–	5,0	5,0	6,0 7,0 <sup>2)</sup>
$b_2$	0 –0,05	–	2,5	2,5	2,5
$d_2$	0 –0,02	2,9 3,8 <sup>1)</sup>	–	–	–
$l_2$	±0,025	2,95	3,95	5,65	6,45

1) For checking the earthing contact of 2,5 A connectors.  
2) For checking the earthing contact of 16 A connectors.

The pins of the gauge shall be made from a conductive material.

The appropriate gauge shall be applied to the entry hole of each socket contact of the connector with a force not exceeding 5 N. When the gauge is fully inserted, the longer pin of the gauge ("contact gauge") shall make contact and the shorter pin ("no contact gauge") shall not make contact.

An electrical indicator with a voltage between 40 V and 50 V is used to show contact with the relevant socket contact.

The contact gauge and the no-contact gauge may be separate.

**Figure 27 – Gauges for checking the distance from the engagement face of connectors to the point of first contact (see 9.1)**



IEC 796/01

**Figure 28 – Thread-forming tapping screw (see 3.19)**

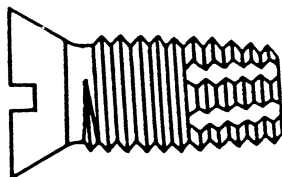

IEC 797/01

**Figure 29 – Thread-cutting tapping screw (see 3.20)**

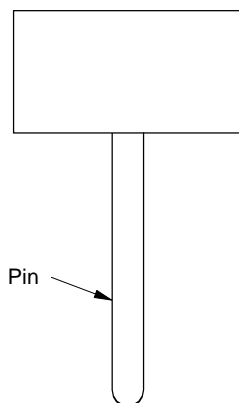

IEC 836/96

*Dimensions according to the relevant standard sheet*

NOTE The mass is to be equally positioned around the centre line(s) of the pin.

**Figure 30 – Gauge for the verification of the minimum withdrawal force**

## Annex A (normative)

### Routine tests for factory wired appliance couplers related to safety (protection against electric shock and correct polarity)

All factory wired accessories shall be subjected to the following tests as appropriate.

Type of accessory	Test to be performed according to clause
Two-pole accessories	A.1
More than two-pole accessories	A.1, A.2, A.3

The test equipment or manufacturing systems shall be such that failed samples are either made unfit for use or separated from satisfactory products in such a way that they cannot be released for sale.

NOTE "Unfit for use" means that the accessory is treated in such a way that it cannot fulfil the intended function. It is, however, accepted that repairable products (by a reliable system) may be repaired and re-tested.

It shall be possible by process or manufacturing system to identify that accessories released for sale have been subjected to all the appropriate tests.

The manufacturer shall maintain a record of the tests carried out which shows

- type of product;
- date of test;
- place of manufacture (if manufactured in more than one place);
- tested quantity;
- number of failures and actions taken, i.e. destroyed/repaired.

The test equipment shall be checked before and after each period of use and for periods of continuous use, at least every 24 h. During these checks the equipment shall show that it indicates faults when known faulty products are inserted or simulated faults are applied.

Products manufactured prior to a check shall only be released for sale if the check is found satisfactory.

Test equipment shall be verified (calibrated) at least once a year.

Records shall be kept of all checks and any adjustments found necessary.

#### **A.1 Polarized systems; Phase (L) and Neutral (N) – Correct connection**

For polarized systems the test shall be made using SELV applied for a period of not less than 2 s between the remote end of the L and N conductors of the flexible cord independently and the corresponding L and N pin or contact of the accessory.

NOTE The period of 2 s may be reduced to not less than 1 s on test equipment with automatic timing.

Other suitable tests may be used.

Polarity shall be correct.

## **A.2 Earth (E) continuity**

The test shall be made using SELV applied for a period of not less than 2 s between the remote end of the E conductor of the flexible cord and the E pin or contact of the accessory, as appropriate.

NOTE The period of 2 s may be reduced to not less than 1 s on test equipment with automatic timing.

Other suitable tests may be used.

Continuity shall be present.

## **A.3 Short circuit/wrong connection and reduction in creepage distance and clearance L or N to E**

The test shall be made between the L and N conductors and the E conductor by applying at the supply end an a.c. voltage of 2 000 V  $\pm$  200 V, 50 Hz or 60 Hz for a period of not less than 2 s,

NOTE The period of 2 s may be reduced to not less than 1 s on test equipment with automatic timing.

or

by an impulse voltage test using 1,2/50  $\mu$ s wave form, 4 kV peak value, three impulses for each pole, with intervals of not less than 1 s, the test voltage being applied at the supply end.

The L and N conductors may be connected together for this test.

No flashover shall occur.

---