

มาตรฐานผลิตภัณฑ์อุตสาหกรรม

THAI INDUSTRIAL STANDARD

มอก.2510 เล่ม 2 – 2553

ISO 14855 – 2 : 2005

การหาการแตกสลายทางชีวภาพในขั้นสุดท้าย
แบบใช้ออกซิเจนของพลาสติกภายใต้สภาวะ
ควบคุมการหมักทางชีวภาพ –
วิธีวิเคราะห์คาร์บอนไดออกไซด์ที่เกิดขึ้น –
เล่ม 2 : การชั่งน้ำหนักคาร์บอนไดออกไซด์ที่เกิดขึ้นในการทดสอบระดับ
ห้องปฏิบัติการ

DETERMINATION OF THE ULTIMATE AEROBIC BIODEGRADABILITY
OF PLASTIC MATERIALS UNDER CONTROLLED COMPOSTING
CONDITIONS - METHOD BY ANALYSIS OF EVOLVED CARBON DIOXIDE -
PART 2 : GRAVIMETRIC MEASUREMENT OF CARBON DIOXIDE EVOLVED
IN A LABORATORY-SCALE TEST

สำนักงานมาตรฐานผลิตภัณฑ์อุตสาหกรรม

กระทรวงอุตสาหกรรม

ICS 83.080.01

ISBN 978-974-292-980-0

มาตรฐานผลิตภัณฑ์อุตสาหกรรม
การหาการแตกสลายทางชีวภาพในขั้นสุดท้าย
แบบใช้ออกซิเจนของพลาสติกภายใต้สภาวะ
ควบคุมการหมักทางชีวภาพ-
วิธีวิเคราะห์คาร์บอนไดออกไซด์ที่เกิดขึ้น -
เล่ม 2 : การชั่งน้ำหนักคาร์บอนไดออกไซด์ที่เกิดขึ้นใน
การทดสอบระดับห้องปฏิบัติการ

มอก.2510 เล่ม 2-2553

สำนักงานมาตรฐานผลิตภัณฑ์อุตสาหกรรม
กระทรวงอุตสาหกรรม ถนนพระรามที่ 6 กรุงเทพฯ 10400
โทรศัพท์ 0 2202 3300

ประกาศในราชกิจจานุเบกษา ฉบับประกาศและงานทั่วไป เล่ม 127 ตอนพิเศษ 83ง
วันที่ 7 กรกฎาคม พุทธศักราช 2553

คณะกรรมการวิชาการคณะที่ 1031
มาตรฐานพลาสติกชีวภาพ

ประธานกรรมการ

รศ.ดร.พิฑูร ตรีวิจิตรเกษม

-

กรรมการ

รศ.ดร.ปราณี ภิญโญชีพ

-

รศ.ดร.ศิริพร ดำรงค์ศักดิ์กุล

-

รศ.ดร.สุวนุญ จิรชาญชัย

-

นางสุมาลี ทั้งพิทยกุล

กรมวิทยาศาสตร์บริการ

ดร.วันทนีย์ จองคำ

สำนักงานนวัตกรรมแห่งชาติ

นายกรภัทร สมแสง

ดร.สุพจน์ ประทีปถิ่นทอง

สถาบันวิจัยวิทยาศาสตร์และเทคโนโลยีแห่งประเทศไทย

ดร.ธนาวดี ลีจากภัย

ศูนย์เทคโนโลยีโลหะและวัสดุแห่งชาติ

รศ.ดร.งามทิพย์ ภู่วโรดม

มหาวิทยาลัยเกษตรศาสตร์

นายสมศักดิ์ บริสุทธิ์นะกุล

บริษัท อุตสาหกรรมถุงพลาสติกไทย จำกัด

นายสุรศักดิ์ เหลืองอร่ามศรี

บริษัท บรรจุก๊าซเพื่อสิ่งแวดล้อม จำกัด

กรรมการและเลขานุการ

นางกรรณิการ์ โตประเสริฐพงศ์

สำนักงานมาตรฐานผลิตภัณฑ์อุตสาหกรรม

กรรมการและผู้ช่วยเลขานุการ

นายอาศิรวรรณ โพธิพันธ์

สำนักงานมาตรฐานผลิตภัณฑ์อุตสาหกรรม

เนื่องจากวิธีวิเคราะห์คาร์บอนไดออกไซด์ที่เกิดขึ้น - เล่ม 2 : การชั่งน้ำหนักคาร์บอนไดออกไซด์ที่เกิดขึ้น ในการทดสอบระดับห้องปฏิบัติการ เป็นเล่มหนึ่งในชุดการหาการแตกสลายทางชีวภาพในขั้นสุดท้าย แบบใช้ออกซิเจนของพลาสติกภายใต้สภาวะควบคุมการหมักทางชีวภาพ จึงกำหนดมาตรฐานผลิตภัณฑ์ อุตสาหกรรม การหาการแตกสลายทางชีวภาพในขั้นสุดท้ายแบบใช้ออกซิเจนของพลาสติกภายใต้สภาวะควบคุม การหมักทางชีวภาพ - วิธีวิเคราะห์คาร์บอนไดออกไซด์ที่เกิดขึ้น - เล่ม 2 : การชั่งน้ำหนักคาร์บอนไดออกไซด์ที่ เกิดขึ้นในการทดสอบระดับห้องปฏิบัติการขึ้น

มาตรฐานผลิตภัณฑ์อุตสาหกรรมนี้ กำหนดขึ้นโดยรับ ISO 14855-2 : 2007 Determination of the ultimate aerobic biodegradability of plastic materials under controlled composting conditions - Method by analysis of evolved carbon dioxide-Part 2 : Gravimetric measurement of carbon dioxide evolved in a laboratory-scale test มาใช้ในระดับเหมือนกันทุกประการ (identical) โดยใช้ ISO ฉบับภาษาอังกฤษเป็นหลัก

มาตรฐานผลิตภัณฑ์อุตสาหกรรมนี้ กำหนดขึ้นเพื่อให้ทันกับความต้องการของผู้ใช้ และจักได้แปลเป็นภาษาไทย ในโอกาสอันควร หากมีข้อสงสัยโปรดติดต่อสอบถามที่สำนักงานมาตรฐานผลิตภัณฑ์อุตสาหกรรม

คณะกรรมการมาตรฐานผลิตภัณฑ์อุตสาหกรรมได้พิจารณามาตรฐานนี้แล้ว เห็นสมควรเสนอรัฐมนตรีประกาศตาม มาตรา 15 แห่งพระราชบัญญัติมาตรฐานผลิตภัณฑ์อุตสาหกรรม พ.ศ. 2511



ประกาศกระทรวงอุตสาหกรรม

ฉบับที่ 4192 (พ.ศ. 2553)

ออกตามความในพระราชบัญญัติมาตรฐานผลิตภัณฑ์อุตสาหกรรม

พ.ศ. 2511

เรื่อง กำหนดมาตรฐานผลิตภัณฑ์อุตสาหกรรม

การหาการแตกสลายทางชีวภาพในขั้นสุดท้าย

แบบใช้ออกซิเจนของพลาสติกภายใต้สภาวะควบคุมการหมักทางชีวภาพ-

วิธีวิเคราะห์คาร์บอนไดออกไซด์ที่เกิดขึ้น-

เล่ม 2 : การชั่งน้ำหนักคาร์บอนไดออกไซด์ที่เกิดขึ้นในการทดสอบระดับห้องปฏิบัติการ

อาศัยอำนาจตามความในมาตรา 15 แห่งพระราชบัญญัติมาตรฐานผลิตภัณฑ์อุตสาหกรรม พ.ศ. 2511 รัฐมนตรีว่าการกระทรวงอุตสาหกรรมออกประกาศกำหนดมาตรฐานผลิตภัณฑ์อุตสาหกรรม การหาการแตกสลายทางชีวภาพในขั้นสุดท้ายแบบใช้ออกซิเจนของพลาสติกภายใต้สภาวะควบคุมการหมักทางชีวภาพ - วิธีวิเคราะห์คาร์บอนไดออกไซด์ที่เกิดขึ้น - เล่ม 2 : การชั่งน้ำหนักคาร์บอนไดออกไซด์ที่เกิดขึ้นในการทดสอบระดับห้องปฏิบัติการ มาตรฐานเลขที่ มอก.2510 เล่ม 2-2553 ไว้ ดังมีรายการละเอียดต่อท้ายประกาศนี้

ประกาศ ณ วันที่ 23 เมษายน พ.ศ. 2553

ชาญชัย ชัยรุ่งเรือง

รัฐมนตรีว่าการกระทรวงอุตสาหกรรม

มาตรฐานผลิตภัณฑ์อุตสาหกรรม
การหาการแตกสลายทางชีวภาพในขั้นสุดท้าย
แบบใช้ออกซิเจนของพลาสติกภายใต้สภาวะ
ควบคุมการหมักทางชีวภาพ-
วิธีวิเคราะห์คาร์บอนไดออกไซด์ที่เกิดขึ้น-
เล่ม 2 : การชั่งน้ำหนักคาร์บอนไดออกไซด์ที่เกิดขึ้น
ในการทดสอบระดับห้องปฏิบัติการ

บทนำ

มาตรฐานผลิตภัณฑ์อุตสาหกรรมนี้กำหนดขึ้นโดยรับ ISO 14855-2 : 2005 Determination of the ultimate aerobic biodegradability of plastic materials under controlled composting conditions – Part 1 Method by analysis of evolved carbon dioxide – Part 2 : Gravimetric measurement of carbon dioxide evolved in a laboratory-scale test มาใช้ในระดับเหมือนกันทุกประการ (identical) โดยใช้ ISO ฉบับภาษาอังกฤษเป็นหลัก มาใช้ในระดับเหมือนกันทุกประการ (identical) โดยใช้ ISO ฉบับภาษาอังกฤษเป็นหลัก

ขอบข่าย

มาตรฐานผลิตภัณฑ์อุตสาหกรรมนี้ กำหนดการหาการแตกสลายทางชีวภาพในขั้นสุดท้ายแบบใช้ออกซิเจนของพลาสติกภายใต้สภาวะการควบคุมการหมักทางชีวภาพ โดยการชั่งน้ำหนักคาร์บอนไดออกไซด์ที่เกิดขึ้น วิธีนี้ทำเพื่อให้ได้อัตราการแตกสลายทางชีวภาพที่เหมาะสมโดยการปรับความชื้น การหมุนเวียนของอากาศและอุณหภูมิในถังหมัก

วิธีการทดสอบนี้ใช้ได้กับวัสดุต่อไปนี้

- พอลิเมอร์ธรรมชาติและ/หรือพอลิเมอร์สังเคราะห์ และโคพอลิเมอร์และของผสมของพอลิเมอร์ดังกล่าว
- วัสดุที่มีสารเติมแต่ง เช่น สารเสริมสภาพพลาสติก (plasticizers) สารให้สี (colorants)
- พอลิเมอร์ละลายน้ำได้
- วัสดุที่ไม่มีฤทธิ์ยับยั้งกิจกรรมของจุลินทรีย์ในเชื้อปลูกภายใต้สภาวะการทดสอบ

กรณีวัสดุมีฤทธิ์ยับยั้งกิจกรรมของจุลินทรีย์ในเชื้อปลูก ให้ใช้แทนด้วยปุ๋ยหมักที่ผ่านการบ่มหรือเคยนำมาใช้ทดสอบแล้ว

เอกสารอ้างอิง

รายละเอียดให้เป็นที่ไปตาม ISO 14855-2 : 2007 ข้อ 2

คำศัพท์และบทนิยาม

ความหมายของคำที่ใช้ในมาตรฐานผลิตภัณฑ์อุตสาหกรรมนี้ ให้เป็นที่ไปตาม ISO 14855-2 : 2007 ข้อ 3

หลักการ

รายละเอียดให้เป็นที่ไปตาม ISO 14855-2 : 2007 ข้อ 4

สารเคมี

รายละเอียดให้เป็นที่ไปตาม ISO 14855-2 : 2007 ข้อ 5

เครื่องมือ

รายละเอียดให้เป็นที่ไปตาม ISO 14855-2 : 2007 ข้อ 6

การทดสอบ

รายละเอียดให้เป็นที่ไปตาม ISO 14855-2 : 2007 ข้อ 7

การคำนวณ

รายละเอียดให้เป็นที่ไปตาม ISO 14855-2 : 2007 ข้อ 8

การแสดงผลและการแปลผลทดสอบ

รายละเอียดให้เป็นที่ไปตาม ISO 14855-2 : 2007 ข้อ 9

การใช้ได้ของผลลัพธ์

รายละเอียดให้เป็นที่ไปตาม ISO 14855-2 : 2007 ข้อ 10

การรายงานผลทดสอบ

รายละเอียดให้เป็นไปตาม ISO 14855-2 : 2007 ข้อ 11

ภาคผนวก

รายละเอียดให้เป็นไปตาม ISO 14855-2 : 2007 Annex A



© ISO 2007

เอกสารนี้เป็นสิทธิ์ของ ISO หากมิได้กำหนดไว้เป็นอย่างอื่นห้ามนำมาตรฐานฉบับนี้หรือ
ส่วนหนึ่งส่วนใดไปทำซ้ำหรือใช้ประโยชน์ในรูปแบบ หรือโดยวิธีใด ๆ ไม่ว่าจะในรูปแบบ
อิเล็กทรอนิกส์หรือทางกล รวมถึงการถ่ายสำเนา ถ่ายไมโครฟิล์ม โดยไม่ได้รับอนุญาตเป็น
ลายลักษณ์อักษรจาก ISO ตามที่อยู่ข้างล่างหรือจากสมาชิก ISO ในประเทศของผู้ร้องขอ

ISO copyright office

Case postale 56 • CH-1211 Geneva 20

Tel.+ 41 22 749 01 11

Fax+ 41 22 749 09 47

E-mail : copyright@iso.org

Web : www.iso.org

PDF disclaimer

This PDF file may contain embedded typefaces. In accordance with Adobe's licensing policy, this file may be printed or viewed but shall not be edited unless the typefaces which are embedded are licensed to and installed on the computer performing the editing. In downloading this file, parties accept therein the responsibility of not infringing Adobe's licensing policy. The ISO Central Secretariat accepts no liability in this area.

Adobe is a trademark of Adobe Systems Incorporated.

Details of the software products used to create this PDF file can be found in the General Info relative to the file; the PDF-creation parameters were optimized for printing. Every care has been taken to ensure that the file is suitable for use by ISO member bodies. In the unlikely event that a problem relating to it is found, please inform the Central Secretariat at the address given below.



COPYRIGHT PROTECTED DOCUMENT

© ISO 2007

All rights reserved. Unless otherwise specified, no part of this publication may be reproduced or utilized in any form or by any means, electronic or mechanical, including photocopying and microfilm, without permission in writing from either ISO at the address below or ISO's member body in the country of the requester.

ISO copyright office
Case postale 56 • CH-1211 Geneva 20
Tel. + 41 22 749 01 11
Fax + 41 22 749 09 47
E-mail copyright@iso.org
Web www.iso.org

Published in Switzerland

Contents	Page
1 Scope	1
2 Normative references	1
3 Terms and definitions	2
4 Principle	3
5 Reagents	3
6 Apparatus	4
7 Procedure	5
8 Calculation	8
9 Expression and interpretation of results	9
10 Validity of results	9
11 Test report	9
Annex A (informative) Basic principle of the test	10
Annex B (informative) Example of an apparatus using an electrically heated composting vessel ..	12
Annex C (informative) Derivation of the equation used to calculate the degree of biodegradation from the amount of carbon dioxide evolved	14
Bibliography	15

Foreword

ISO (the International Organization for Standardization) is a worldwide federation of national standards bodies (ISO member bodies). The work of preparing International Standards is normally carried out through ISO technical committees. Each member body interested in a subject for which a technical committee has been established has the right to be represented on that committee. International organizations, governmental and non-governmental, in liaison with ISO, also take part in the work. ISO collaborates closely with the International Electrotechnical Commission (IEC) on all matters of electrotechnical standardization.

International Standards are drafted in accordance with the rules given in the ISO/IEC Directives, Part 2.

The main task of technical committees is to prepare International Standards. Draft International Standards adopted by the technical committees are circulated to the member bodies for voting. Publication as an International Standard requires approval by at least 75 % of the member bodies casting a vote.

Attention is drawn to the possibility that some of the elements of this document may be the subject of patent rights. ISO shall not be held responsible for identifying any or all such patent rights.

ISO 14855-2 was prepared by ~~Technical Committee ISO/TC 61, Plastics, Subcommittee SC 5, Physical-chemical properties.~~

ISO 14855 consists of the following parts, under the general title *Determination of the ultimate aerobic biodegradability of plastic materials under controlled composting conditions — Method by analysis of evolved carbon dioxide*:

- Part 1: General method
- Part 2: Gravimetric measurement of carbon dioxide evolved in a laboratory-scale test

Introduction

Management of plastics waste is a serious problem in the world. Plastics recovery technologies include material recovery (mechanical recycling, chemical or feedstock recycling, and biological or organic recycling) and energy recovery (heat, steam or electricity as a substitute for fossil fuels or other fuel resources). The use of biodegradable plastics is one valuable recovery option (biological or organic recycling).

Several ISO standards for determining the ultimate aerobic/anaerobic biodegradability of plastic materials have been published. In particular, ISO 14855-1 is a common test method that measures the amount of carbon dioxide evolved using methods such as continuous infrared analysis, gas chromatography or titration. Compared with ISO 14855-1, the amounts of compost inoculum and test sample used in this part of ISO 14855 are one-tenth the size. In order to ensure the activity of the compost inoculum, inert material that gives the mixture the same texture as soil is mixed into the inoculum. The carbon dioxide evolved from the test vessel is determined by absorbing it in a carbon dioxide trap and carrying out gravimetric analysis of the absorbent. The method described in this part of ISO 14855, which uses a closed system to capture the carbon dioxide evolved, can also be used to obtain valuable information, by means of isotopic-labelling studies, on the way in which the molecular structure of co-polymers degrades.

Determination of the ultimate aerobic biodegradability of plastic materials under controlled composting conditions — Method by analysis of evolved carbon dioxide —

Part 2: Gravimetric measurement of carbon dioxide evolved in a laboratory-scale test

WARNING — Sewage, activated sludge, soil and compost may contain potentially pathogenic organisms. Therefore appropriate precautions should be taken when handling them. Toxic test compounds and those whose properties are unknown should be handled with care.

1 Scope

This part of ISO 14855 specifies a method for determining the ultimate aerobic biodegradability of plastic materials under controlled composting conditions by gravimetric measurement of the amount of carbon dioxide evolved. The method is designed to yield an optimum rate of biodegradation by adjusting the humidity, aeration and temperature of the composting vessel.

The method applies to the following materials:

- natural and/or synthetic polymers and copolymers, and mixtures of these;
- plastic materials that contain additives such as plasticizers or colorants;
- water-soluble polymers;
- materials that, under the test conditions, do not inhibit the activity of micro-organisms present in the inoculum.

If the test material inhibits micro-organisms in the inoculum, another type of mature compost or pre-exposure compost can be used.

2 Normative references

The following referenced documents are indispensable for the application of this document. For dated references, only the edition cited applies. For undated references, the latest edition of the referenced document (including any amendments) applies.

ISO 5663, *Water quality — Determination of Kjeldahl nitrogen — Method after mineralization with selenium*

ISO 8245, *Water quality — Guidelines for the determination of total organic carbon (TOC) and dissolved organic carbon (DOC)*

ISO 11721-1, *Textiles — Determination of resistance of cellulose-containing textiles to micro-organisms — Soil burial test — Part 1: Assessment of rot-retardant finishing*

ISO 14855-1, *Determination of the ultimate aerobic biodegradability of plastic materials under controlled composting conditions — Method by analysis of evolved carbon dioxide — Part 1: General method*

ISO 14855-2:2007(E)

3 Terms and definitions

For the purposes of this document, the following terms and definitions apply.

3.1

compost

organic soil conditioner obtained by biodegradation of a mixture principally consisting of various vegetable residues, occasionally with other organic material and having a limited mineral content

3.2

composting

aerobic process designed to produce compost

3.3

total dry solids

amount of solids obtained by taking a known volume of test material or compost and drying at about 105 °C to constant mass

3.4

volatile solids

amount of solids obtained by subtracting the residue of a known volume of test material or compost after incineration at about 550 °C from the total dry solids of the same sample

NOTE The volatile-solids content is an indication of the amount of organic matter present.

3.5

ultimate aerobic biodegradation

breakdown of an organic compound by micro-organisms in the presence of oxygen into carbon dioxide, water and mineral salts of any other elements present (mineralization) plus new biomass

3.6

theoretical amount of evolved carbon dioxide**ThCO₂**

maximum theoretical amount of carbon dioxide evolved after completely oxidizing a chemical compound, calculated from the molecular formula and expressed as milligrams of carbon dioxide evolved per milligram or gram of test compound

3.7

lag phase

time, measured in days, from the start of a test until adaptation and/or selection of the degradation micro-organisms is achieved and the degree of biodegradation of a chemical compound or organic matter has increased to about 10 % of the maximum level of biodegradation

3.8

maximum level of biodegradation

degree of biodegradation, measured as a percentage, of a chemical compound or organic matter in a test, above which no further biodegradation takes place during the test

3.9

biodegradation phase

time, measured in days, from the end of the lag phase of a test until about 90 % of the maximum level of biodegradation has been reached

3.10

plateau phase

time, measured in days, from the end of the biodegradation phase until the end of the test

3.11**pre-exposure**

pre-incubation of an inoculum in the presence of the chemical compound or organic matter under test, with the aim of enhancing the ability of the inoculum to biodegrade the test material by adaptation and/or selection of the micro-organisms

3.12**pre-conditioning**

pre-incubation of an inoculum under the conditions of the subsequent test in the absence of the chemical compound or organic matter under test, with the aim of improving the test by acclimatization of the micro-organisms to the test conditions

3.13**water-holding capacity****WHC**

mass of water that evaporates from soil saturated with water when the soil is dried to constant mass at 105 °C, divided by the dry mass of the soil

4 Principle

This method is designed to yield the optimum rate of biodegradation of a plastic material in mature compost by controlling the humidity, aeration ratio and temperature in the composting vessel. It also aims to determine the ultimate biodegradability of the test material by using a small-scale reactor. The degradation rate is periodically measured by determining the mass of the evolved carbon dioxide using an absorption column filled with soda lime and soda talc on an electronic balance.

The test material is mixed with an inoculum derived from mature compost and with an inert material such as sea sand. The sea sand plays an active part by acting as a holding body for humidity and micro-organisms. Examples of suitable test arrangements are presented in Annexes A and B. The amount of carbon dioxide evolved is measured at intervals on an electronic balance and the carbon dioxide content is determined using the following method. The derivation of the equation used to calculate the degree of biodegradation from the amount of carbon dioxide evolved is given in Annex C. In this method, the degree of biodegradation, expressed as a percentage, is calculated by comparing the amount of carbon dioxide evolved with the theoretical amount (ThCO_2).

The test is terminated when the plateau phase of biodegradation has been attained. The standard time for termination is 45 days, but the test could be continued for up to six months.

5 Reagents

Use only analytical-grade reagents. Use only deionized water.

5.1 Soda lime, particle size between 2 mm and 4 mm, for CO_2 absorption.

5.2 Anhydrous calcium chloride, particle size between 2 mm and 3 mm, for water absorption.

5.3 Sodium hydroxide on a talc support (commonly known as soda talc), particle size between 2 mm and 2 mm, for CO_2 absorption.

5.4 Silica gel (with moisture indicator), particle size between 2 mm and 4 mm, for water absorption.

5.5 Sea sand, particle size between 20 mesh and 35 mesh.

5.6 Reference material: TLC (thin-layer chromatography) grade microcrystalline cellulose with a particle size of less than 20 μm , for use as the reference material in the positive control.

6 Apparatus

Ensure that all glassware is thoroughly cleaned and, in particular, free from organic or toxic matter.

6.1 Air-supply system

The air-supply system shall be capable of supplying each composting vessel with carbon-dioxide-free, water-saturated air. The air can be prepared by supplying compressed air through a carbon dioxide trap and a humidifier (see examples in Annexes A and B), i.e. columns filled with soda lime and water, respectively. The air flow rate shall be controlled with a flow controller so that it is high enough for aerobic conditions.

6.2 Composting vessels

Use bottles or columns that ensure a supply of water-saturated, carbon-dioxide-free air to the contents. A suitable volume is 500 ml. If the loss in mass of the test material is to be determined, weigh each composting vessel empty before starting the test.

6.3 System for the determination of carbon dioxide

This system shall be capable of determining carbon dioxide directly from the change in mass of a carbon dioxide trap. The carbon dioxide trap shall consist of columns filled with soda lime, soda talc and anhydrous calcium chloride. The calcium chloride should preferably be in a separate column from the soda lime and soda talc (see examples in Annexes A and B). An ammonia trap (dilute sulfuric acid) and a water trap (silica gel and calcium chloride) are required between the composting vessel and the carbon-dioxide-absorbing column.

6.4 Gas-tight tubes

These tubes are used to connect the composting vessels to the air supply and the carbon dioxide measurement system.

6.5 pH-meter

The pH-meter is used for measurement of the pH of the test mixture. It shall be accurate to 0,1 pH-units or better.

6.6 Analytical equipment

This equipment is used for the determination of the dry solids (at 105 °C), volatile solids (at 550 °C) and total organic carbon (TOC), for elemental analysis of the test material and, if required, for the determination of dissolved inorganic carbon (DIC), volatile fatty acids, oxygen in the air, water content and total nitrogen.

6.7 Balance

The balance is used to periodically measure the mass of the carbon-dioxide-absorbing column, in order to determine the amount of carbon dioxide evolved, and also to measure the mass of the composting vessel containing compost and test material. A top-loading electronic balance with a display reading down to 10 mg and a capacity greater than 500 g is preferred.

6.8 Thermostatic-control unit

This unit is required to maintain the temperature of the composting vessels at a controlled temperature during the test (see examples given in Annexes A and B). It shall be capable of maintaining the temperature of the composting vessels constant to within ± 2 °C.

6.9 Composting bioreactor

A composting bioreactor is a box, made from polypropylene or another suitable material, having a size that allows the contents to be stirred easily with a spatula. The box shall be provided with a tightly fitting lid to avoid excessive water loss. Three holes with a diameter of about 1 cm shall be made at equal distances along the centreline of the lid. These holes allow air to enter and gases to leave the box, as well as the gradual evaporation of excess water.

7 Procedure

7.1 Preparation of the inoculum

Well-aerated compost from a properly operating aerobic composting plant shall be used as the inoculum. The inoculum shall be homogeneous and free from large inert objects such as glass, stones or pieces of metal. Remove such items manually and then sieve the compost on a screen of about 3 mm mesh.

Compost can be made as follows. Wood shavings, sawdust, used mushroom beds, chaff or rice straw is used as the carbon source. Livestock excrement is added as a source of composting micro-organisms and mineral salt nutrients. This is placed in a container with a volume of about 1 m³ and mixed well. It is recommended that the compost be adjusted to a carbon/nitrogen (C/N) ratio of 15 and a carbon/phosphorous (C/P) ratio of 30. Insufficient phosphorous levels can be supplemented using calcium superphosphate. Water is added to reach a water content equal to 65 %. The C/N, C/P and water-content values may also be adjusted to other values, determined by experience, depending on seasonal variations and climatic differences. The compost should be removed from the container once a week to turn it and add water if necessary, before returning it to the container to continue the composting process. The age of the compost should preferably be between two and four months.

Normally, non-exposed inoculum is preferred, especially in the case of standard tests simulating biodegradation behaviour in real composting facilities. Depending on the purpose of the test, however, pre-exposed compost may be used, provided that this is clearly stated in the test report (e.g. percent biodegradation = X %, using pre-exposed compost) and provided the method of pre-exposure is detailed in the test report.

Determine the total dry solids and volatile-solids content of the compost inoculum. The total dry solids should be between 35 % and 55 % of the wet solids and the volatile solids more than 30 % of the dry solids. Adjust the water content, if necessary, before the compost is used by adding water or drying gently, e.g. by aerating the compost with dry air.

Prepare a mixture of 1 part of inoculum to 5 parts of deionized water. Mix by shaking and measure the pH immediately. It should be between 7,0 and 9,0.

For further characterization of the inoculum, suitable parameters such as the content of total organic carbon, total nitrogen or fatty acids can optionally be determined at the beginning and the end of the test.

Check the activity of the inoculum during the test by means of a biodegradable reference material and by measuring carbon dioxide evolution in the blank vessels. The reference material shall be degraded by 70 % or more at the end of the test. The inoculum in the blank should produce between 50 mg and 150 mg of carbon dioxide per gram of volatile solids over the first 10 days of the test. If the production of carbon dioxide is too high, stabilize the compost by aeration for several days before using it in a new test.

7.2 Preparation of the sea sand

Dip the sea sand in tap water. After removing floating impurities by decantation, rinse the sand sufficiently, drain off the water and dry the sand at about 105 °C.

NOTE Sea sand is an inert product that contains more than 90 % of SiO₂. It plays an important role, however, in maintaining an appropriate water content and as a support for microbial growth.

ISO 14855-2:2007(E)

7.3 Preparation of test material and reference material

Determine the total organic carbon (TOC) of the test material and the reference material using e.g. ISO 8245 and report it preferably as grams of TOC per gram of total dry solids. Alternatively, provided that the materials do not contain inorganic carbon, it is possible to determine the carbon content by elemental analysis. For this, the test material has to contain sufficient organic carbon to yield carbon dioxide in an amount suitable for determination. Normally, a minimum of 10 g of total dry solids containing 4 g of TOC is required per vessel.

The test material should preferably be used in powder form, but it may also be introduced as small pieces of films or as fragments of shaped articles. A maximum particle size of 250 μm in diameter is recommended.

7.4 Starting up the test

Provide at least the following numbers of composting vessels:

- a) two test vessels for the test mixture (symbol V_T);
- b) two vessels for blank controls (symbol V_B);
- c) two vessels for checking inoculum activity using a reference material (symbol V_R).

The amount of test mixture, containing inoculum and the test material, used in the test depends on the quality of the test material and the size of the composting vessels. The relation between the total dry solids of the inoculum and the total dry solids of the test material should preferably be about 6:1. If added, inert material is not considered in this relationship. The test mixture should have the same water content as the inoculum. The water content of the test mixture should be set at 80 % to 90 % of the water-holding capacity (WHC) of the test mixture. The same amount of inoculum by total dry solids should be placed in each test vessel.

In a typical case, prepare lidded vessels that have a volume of about 500 ml, weigh out, for each vessel, an amount of inoculum containing 60 g of total dry solids and add sufficient water to reach a water content of 65 %. After mixing well, leave the compost to stand at room temperature for 24 h. Then mix the compost well with sea sand with a water content of 15 % that has previously been prepared by the addition of water to about 320 g of sea sand and is used as inert material. Add 10 g, on a dry-mass basis, of test material to the mixture and mix well. It should feel like soil when handled gently. If required, measure the WHC of the test mixture in accordance with ISO 11721-1, then adjust the water content of the mixture to about 90 % of the WHC by adding water or by aerating with dry air. Introduce the mixture into the composting vessel. If vermiculite is used as the inert material, prepare it as specified in ISO 14855-1.

When mature compost preserved in the refrigerator is used as the inoculum, pre-condition the compost before using it. In a typical case, place, for each vessel, 60 g, on a total dry solids basis, of mature compost in a composting bioreactor, and adjust the water content of the compost to about 110 % of the WHC by adding water. After mixing, allow it to stand at room temperature for 24 h, and then incubate it at 58 °C for 24 h. Add the same volume of sea sand (about 320 g on a dry-mass basis) as the mature compost and mix well. Before addition, the water content of the sea sand should be adjusted to about 15 % (equal to the sea sand WHC value). If required, add 10 g of ammonium magnesium phosphate hexahydrate as a nitrogen source. Put the mixture in the composting bioreactor and incubate for a week at 58 °C. A few times per day, stir the mixture for about 10 min in order to ensure aerobic conditions and allow excess water to evaporate. After a week, adjust the water content of the mixture to about 90 % of its WHC. The final mixture should weigh about 550 g, but a different final mass could be obtained depending on the compost used (different composts will have different WHC values). Add 10 g, on a dry-mass basis, of test material to the mixture and mix well. Introduce the mixture into the composting vessels.

When ISO 14855-1 biodegradability tests are performed, mature compost with a water content of about 50 % shall be used, as specified in ISO 14855-1. Use 120 g of mature compost, containing about 60 g of total dry solids, per composting vessel. Add 10 g, on a dry-mass basis, of test material to the mature compost and mix well. Introduce the mixture into the composting vessel. If the test mixture dries out too fast, put an inert water-containing material in the vessel together with the mixture. However, the water-containing material shall not be mixed with the test mixture.

The organic carbon content can be calculated from the TOC of the inoculum and the test material. The total nitrogen content can be measured in a representative sample of the test mixture, e.g. by the Kjeldahl method described in ISO 5663.

Place the composting vessels in the test environment at $58^{\circ}\text{C} \pm 2^{\circ}\text{C}$ and initiate aeration using air that is free from carbon dioxide and has a normal water content. Both these conditions can be met by e.g. passing the air through a carbon dioxide trap filled with soda lime and a humidifier filled with water (see Annexes A and B). Adjust the air flow rate through each composting vessel to the same rate in the range 10 ml/min to 30 ml/min.

Use a sufficiently high flow rate to ensure that aerobic conditions are maintained throughout each composting vessel during the whole test. Check the air flow regularly at the outlets, e.g. by using wash-bottles or a soap bubble flow meter.

Handle the reference material in the same way as the test material. In the vessels for the blank controls, place only inoculum and sea sand, in the same amounts as in the vessels with the test material.

7.5 Measurement of the evolved carbon dioxide

Fill the ammonia-absorbing bottle with 1 M sulfuric acid to remove any ammonia from the gases which pass out of the composting vessel. Fill the two dehumidifying traps with silica gel and anhydrous calcium chloride, respectively. Fill the carbon-dioxide-absorbing column and water-absorbing column with carbon dioxide absorbent and water absorbent, respectively. The carbon dioxide absorbent should preferably be a mixture of equal quantities of soda lime and soda talc. The water absorbent should preferably be anhydrous calcium chloride. Determine the mass of this trap (i.e. both columns together) to within 10 mg on the balance. The amount of carbon dioxide evolved is determined from the increase in mass of the unit.

Change the reagents in the carbon-dioxide-absorbing and water-absorbing columns when they have reached 80 % of their absorption capacity. Note that 80 g of a mixture of equal quantities of soda lime and soda talc has the ability to absorb about 15 g of carbon dioxide.

7.6 Incubation period

Measure the amount of carbon dioxide evolved in the exhaust air from each composting vessel at intermediate time intervals by measuring the change in mass of the trap for the evolved carbon dioxide. Measure the carbon dioxide evolved at least once a day during the biodegradation phase and once every two days later on, during the plateau phase.

Stir the compost weekly to prevent extensive channelling and to ensure uniform attack by the micro-organisms on the test material. Remove the compost from the vessel to do this. Add water if necessary.

Ensure that the water content of the test mixture in the composting vessels is neither too high nor too low by visual observation. No free-standing water or clumps of material shall be present. Very dry conditions are typically revealed by the absence of condensate in the headspace of the composting vessel. Moisture may also be measured using suitable instruments. In this case, the water content shall be kept at 80 % to 90 % of the WHC of the test mixture. The water content can be controlled by supplying water-saturated or dry air. The desired water content can be obtained by adding water or by drainage via the top of the composting vessel.

During the weekly stirring of the composting vessels and at the end of the test period, record any visual observations with regard to the appearance of the compost, such as structure, water content, colour, fungal development, the smell of the exhaust air and the degree of disintegration of the test material.

Incubate the composting vessels for a period normally not exceeding six months at a constant temperature of $58^{\circ}\text{C} \pm 2^{\circ}\text{C}$. If significant biodegradation of the test material is still observable after six months, the incubation period can be extended until a constant plateau phase is reached. Alternatively, the incubation period can be shortened if the plateau phase is reached earlier.

During the test, if necessary, re-inoculation of the test vessels can be carried out by adding the same amount of compost to each. The origin of the compost and the date of re-inoculation shall be indicated in the test report.

ISO 14855-2:2007(E)

Measure the pH at regular intervals, as at the start of the test.

If the pH is less than 7,0, biodegradation could be inhibited due to acidification of the compost by the rapid degradation of an easily degradable test material. In this case, measurement of the volatile fatty acid spectrum is recommended to check for souring of the contents of the composting vessel. If more than 2 g of volatile fatty acids per kilogram of total dry solids has been formed, then the test shall be regarded as invalid due to acidification and the resultant inhibition of microbial activity. To prevent acidification, add more compost to all the test vessels or repeat the test using, for example, less test material, more compost or pre-exposed compost.

7.7 Termination of the test

When measuring the decrease in mass of the test material, the composting vessel containing the mixture (compost, specimen and inert material such as sea sand) can be reweighed at the end of the test. It is preferable, however, to determine the amounts of dry solids and volatile solids in each vessel after taking the mixture out of the vessel.

8 Calculation**8.1 Theoretical amount of carbon dioxide evolved by test material**

The theoretical amount of carbon dioxide (ThCO_2) evolved by the test material in a test vessel is given, in grams, by Equation (1):

$$\text{ThCO}_2 = m \times w_C \times \frac{44}{12} \quad (1)$$

where

m is the mass of test material, in grams, introduced into the test vessel;

w_C is the carbon content of the test material, determined from the chemical formula or from elemental analysis, expressed as a mass fraction;

44 and 12 are the molecular and atomic masses of carbon dioxide and carbon, respectively.

Calculate in the same way the theoretical amount of carbon dioxide evolved by the reference material in each vessel.

8.2 Percentage biodegradation

Calculate the percentage biodegradation D_t for each test vessel V_T from the amount of carbon dioxide evolved during each measurement interval using Equation (2):

$$D_t = \frac{\sum (\text{CO}_2)_T^t - \sum (\text{CO}_2)_B^t}{\text{ThCO}_2} \times 100 \quad (2)$$

where

$\sum (\text{CO}_2)_T^t$ is the cumulative amount of carbon dioxide, in grams, evolved in the test vessel V_T between the start of the test and time t ;

$\sum (\text{CO}_2)_B^t$ is the mean cumulative amount of carbon dioxide, in grams, evolved in the blank vessels V_B between the start of the test and time t (take the mean of the values obtained for the two blanks);

ThCO_2 is the theoretical amount of carbon dioxide, in grams, evolved by the test material.

9 Expression and interpretation of results

Compile tables containing the measured and calculated data on the test material, the reference material and the blanks for each day of measurement.

Plot the cumulative amount of carbon dioxide evolved by each composting vessel containing test material, blank or reference material as a function of time. Plot biodegradation curves (percentage biodegradation as a function of time) for the test material and the reference material. Use mean values if the difference between the individual values are less than 20 %. If this is not the case, plot biodegradation curves for each composting vessel.

If a plateau phase is observed, read from the biodegradation curve the level of the plateau, i.e. the ultimate degree of biodegradation, and report it as the final test result. If no plateau phase is observed, estimate the ultimate degree of biodegradation from the cumulative amount of carbon dioxide which has evolved by the end of the test.

10 Validity of results

The test is considered as valid if

- a) the degree of biodegradation of the reference material is more than 70 % after 45 days;
- b) the difference between the percentage biodegradation of the reference material in the different vessels is less than 20 % at the end of the test.

If these criteria are not fulfilled, repeat the test using pre-conditioned or pre-exposed compost.

11 Test report

The test report shall provide all pertinent information, including the following:

- a) a reference to this part of ISO 14855;
- b) all information necessary to identify and describe the test material, such as dry- or volatile-solids content, organic-carbon content, shape or visual appearance;
- c) any information necessary to identify and describe the reference material and its organic-carbon content;
- d) the volume of the composting vessels, the amounts of inoculum, test material and reference material placed in them, the times at which the test mixtures were stirred, and details of re-inoculation (if carried out);
- e) information on the inoculum, such as source, age, date of collection, storage, handling, stabilization, total dry solids, volatile solids, pH of suspension, total nitrogen content or volatile fatty acids, as appropriate, and details of any pre-conditioning or pre-exposure;
- f) the results obtained for the carbon dioxide evolved, the percentage biodegradation for each composting vessel, and the averages thereof, in tabular form and graphically, as well as the ultimate degree of biodegradation of the test material and the reference material, and the activity of the inoculum (CO₂ production after 10 days in the blank);
- g) the results of visual observation of the inoculum and the test material during, and at the end of, the test, such as water content, fungal development, structure, colour and smell;
- h) the mass of each composting vessel at the start and the end of the test, and details of any mass-loss measurements, if performed;
- i) the reasons for the rejection of any test results;
- j) information on the source, type and amount of inert material, such as sea sand or vermiculite, used.

Annex A (informative)

Basic principle of the test

A typical test set-up is shown in Figure A.1. It is made up of four basic parts: (1) a composting vessel containing the mixture of test material and inoculum, located in an incubator, (2) an air-feed control system (including a trap to remove the carbon dioxide from the air, a flow-rate controller and a humidifier) to ensure accurate control of the aeration of the test mixture, (3) a gas-absorbing system for removing ammonia, hydrogen sulfide, volatile organic acids and water from the gases evolved from the composting vessel and (4) a trap which absorbs the evolved carbon dioxide for gravimetric analysis.

The composting vessel is kept at $58\text{ }^{\circ}\text{C} \pm 2\text{ }^{\circ}\text{C}$ in the thermostatted incubator. The mixture in each composting vessel is mixed at least once a week in another vessel. An amount of water corresponding to the loss in mass of the mixture is added and, after mixing well, the mixture is returned to the composting vessel. Carbon-dioxide-free, water-saturated air, obtained by passing the air through an absorber filled with soda lime and wash-bottles filled with water, is passed through the composting vessel at a controlled rate. Ammonia, water and any volatile organic acids in the gases evolved from the composting vessel are removed with traps containing 1 M sulfuric acid, silica gel and anhydrous calcium chloride, respectively. The carbon dioxide in these gases is trapped in the form of sodium carbonate and water (formed by the reaction between the carbon dioxide and sodium hydroxide) in a trap containing soda lime and soda talc as well as anhydrous calcium chloride. The remaining absorption capacity of the various traps can readily be monitored by observing the variation in colour of indicators or the gain in mass of the absorbent.

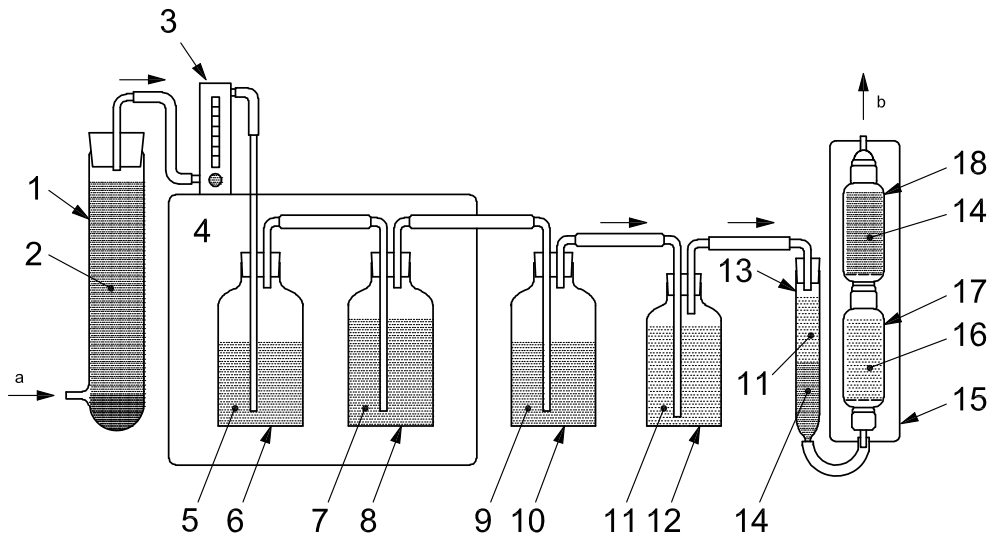

Key

- 1 carbon dioxide trap
- 2 soda lime
- 3 flow meter with controller
- 4 incubator with thermostat
- 5 water
- 6 humidifier
- 7 mixture of compost, test material and sea sand
- 8 composting vessel
- 9 1 M H₂SO₄ containing methyl orange indicator
- 10 ammonia trap
- 11 silica gel
- 12 dehumidifying trap 1
- 13 dehumidifying trap 2
- 14 anhydrous calcium chloride
- 15 trap for evolved carbon dioxide
- 16 mixture of soda lime and soda talc
- 17 carbon dioxide absorption column
- 18 water absorption column

^a Compressed air in.

^b Outlet.

Figure A.1 — Example of a test system using an incubator

Annex B

(informative)

Example of an apparatus using an electrically heated composting vessel

The test set-up shown in Figure B.1 operates in accordance with the same principles as that shown in Annex A, but the composting vessel is designed to allow the test to be continued for longer than the normal. The main advantage of electrical heating is that it does not require the same level of maintenance as, for instance, a water bath. The fact that the composting vessel is not inside an incubator ensures easier handling of the test mixture. Dehumidifying trap 2 (18 in Figure B.1) and the water absorption column (25) have the capacity to work for about one year. The absorbents in dehumidifying trap 1 (17) and the carbon dioxide absorption column (23), however, will have to be refilled several times during the normal 45-day operation.

Dimensions in millimetres

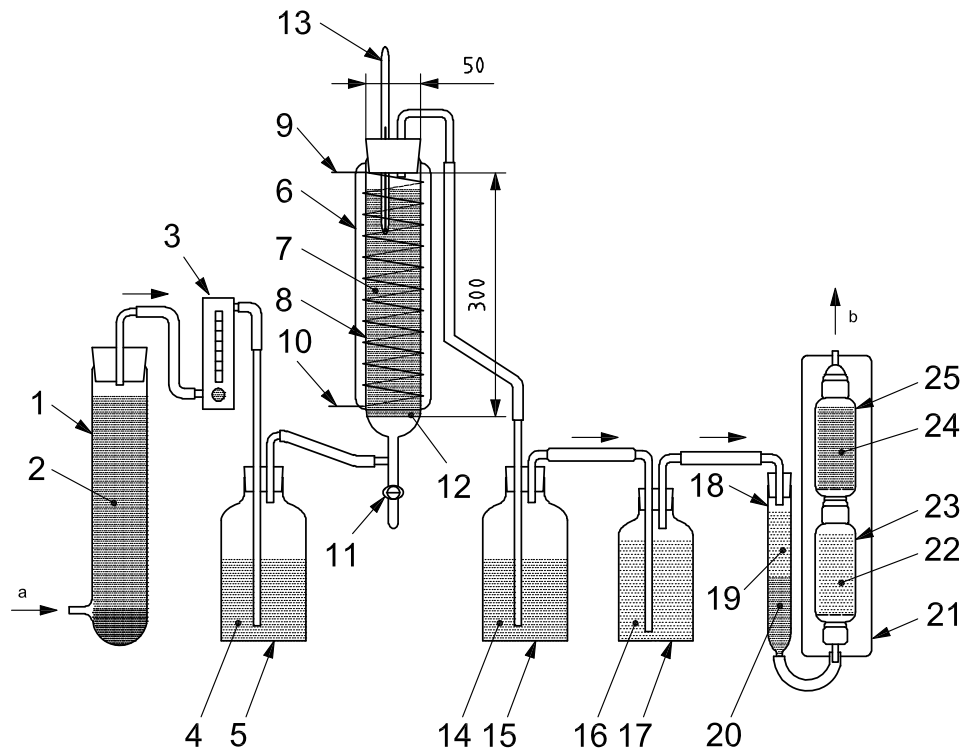

Key

- 1 1 000 ml carbon dioxide trap
 - 2 1 000 g of soda lime
 - 3 flow meter with flow rate controller
 - 4 300 ml of water
 - 5 500 ml humidifier
 - 6 500 ml glass composting vessel
 - 7 mixture of compost, test material and sea sand
 - 8 heat-insulating material
 - 9 upper end of electric heater
 - 10 lower end of electric heater
 - 11 glass cock (to drain water from composting vessel)
 - 12 support for PTFE (polytetrafluoroethylene) filter
 - 13 temperature sensor
 - 14 300 ml of 1 M H₂SO₄ containing methyl orange indicator
 - 15 500 ml ammonia trap
 - 16 silica gel
 - 17 dehumidifying trap 1 (200 ml)
 - 18 dehumidifying trap 2 (120 ml)
 - 19 20 ml of silica gel
 - 20 100 ml of anhydrous calcium chloride
 - 21 trap for evolved carbon dioxide
 - 22 80 g of mixture of soda lime and soda talc
 - 23 120 ml carbon dioxide absorption column
 - 24 anhydrous calcium chloride
 - 25 120 ml water absorption column
- a Compressed air in.
 b Outlet.

Figure B.1 — Example of a test system using an electrically heated composting vessel

Annex C (informative)

Derivation of the equation used to calculate the degree of biodegradation from the amount of carbon dioxide evolved

The amount of evolved carbon dioxide is determined by measuring the gain in mass of the trap for the evolved carbon dioxide (see Annex A). The carbon dioxide evolved reacts quantitatively with the sodium hydroxide and calcium hydroxide contained in the absorbent in the trap as described by the following chemical reactions:



The amount of carbon dioxide evolved during each measurement interval is calculated as in Equation (C.3):

$$\sum(\text{CO}_2)_T^t = (\text{CO}_2)_T^{t=t} - (\text{CO}_2)_T^{t=0} \quad (\text{C.3})$$

where

$\sum(\text{CO}_2)_T^t$ is the cumulative amount of carbon dioxide, in grams, evolved in the test vessel V_T between the start of the test and time t ;

$(\text{CO}_2)_T^{t=0}$ and $(\text{CO}_2)_T^{t=t}$ are the masses of the carbon dioxide trap at the start of the test and at time t , respectively.

Calculate $\sum(\text{CO}_2)_R^t$ and $\sum(\text{CO}_2)_B^t$ in the same way from the cumulative amount of carbon dioxide evolved in the reference vessel and the blank vessel, respectively.

Calculate the percentage biodegradation D_t for each test vessel V_T from the amount of carbon dioxide evolved during each measurement interval using Equation (C.4):

$$D_t = \frac{\sum(\text{CO}_2)_T^t - \sum(\text{CO}_2)_B^t}{\text{ThCO}_2} \times 100 \quad (\text{C.4})$$

where

$\sum(\text{CO}_2)_T^t$ is the cumulative amount of carbon dioxide, in grams, evolved in the test vessel V_T between the start of the test and time t ;

$\sum(\text{CO}_2)_B^t$ is the mean cumulative amount of carbon dioxide, in grams, evolved in the blank vessel between the start of the test and time t ;

ThCO_2 is the theoretical amount of carbon dioxide, in grams, evolved by the test material.

Calculate the percentage biodegradation D_t for each vessel V_R in the same way.

Bibliography

- [1] UEMATSU, S., MURAKAMI, A., HIYOSHI, K., TSUKAMOTO, Y., SAIDA, H., TSUJI, M., and HOSHINO, A., Accurate and Easy Evaluation of Aerobic Microbial Degradability of Biodegradable Plastics under Controlled Soil, *Polymer Reprints*, 2002, **43(2)**, pp. 930-931
- [2] HOSHINO, A., TSUJI, M., ITOH, M., MOMOCHI, M., MIZUTANI, A., TAKAKUWA, K., HIGO, S., SAWADA, H., and UEMATSU, S., Study of Aerobic Biodegradability of Plastic Materials under Controlled Compost, in *Biodegradable Polymers and Plastics*, Eds. Chielline, E., and Solaro, R., Kluwer Academic/Plenum Publishers, New York, 2003, pp. 47-54
- [3] KUNIOKA, M., NINOMIYA, F., and FUNABASHI, M., Biodegradation of poly(lactic acid) powders proposed as the reference test materials for the international standard of biodegradation evaluation methods, *Polymer Degradation and Stability*, 2006, **91**, pp. 1919-1928
- [4] UEMATSU, S., KUNIOKA, M., FUNABASHI, M., WENG, Y., VERMA, S.K., SADOCCO, P., VERSTICHEL, S., EKENDAHL, S., NARAYAN, R., and HOSHINO, A., *Determination of the Ultimate Aerobic Biodegradation of Plastic Materials by Gravimetric Analysis of Evolved Carbon Dioxide under Controlled Composting Conditions — Round-Robin Test for Confirmation of ISO/DIS 14855-2*, in Preprints of the 2nd International Conference of Technology and Application of Biodegradable and Biobased Plastics, Hangzhou (China), ICTABP2, 2006, pp. 224-233